

METRAFLEX METRAGATOR
300 PSI, 6" AXIAL COMPRESSION, WELD ENDS
EXTERNALLY PRESSURIZED EXPANSION JOINT

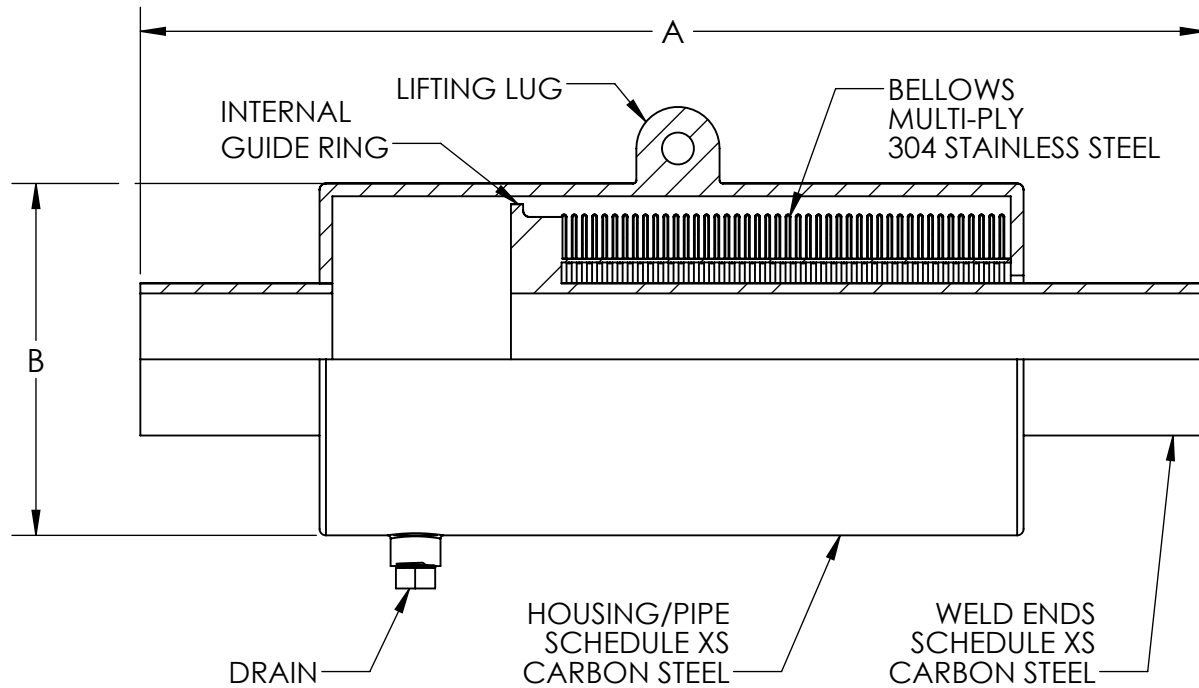

THE EXPANSION JOINT IS DESIGNED FOR AXIAL MOVEMENT ONLY. PIPE MUST BE PROPERLY GUIDED AND ANCHORED PER THE RECOMMENDATIONS OF THE EXPANSION JOINT MANUFACTURERS ASSOCIATION.

QTY	PART NUMBER	PIPE SIZE		A (in)	B (in)	EFF. AREA (in ²)	SPRING RATE (lb/in)	NOTES
		NPS	MM					
	GAT3006SW0200	2	50	36.5	6.625	14.3	434.6	
	GAT3006SW0250	2.5	65	36.5	6.625	14.3	434.6	
	GAT3306SW0300	3	80	33.25	8.625	22.9	650.1	
	GAT3006SW0400	4	100	34.25	10.75	36.4	935.4	
	GAT3006SW0500	5	130	33.25	10.75	46.7	1269.0	
	GAT3006SW0600	6	150	33.25	12.75	59.4	1416.7	
	GAT3006SW0800	8	200	34.5	14	93.0	2036.3	
	GAT3006SW1000	10	250	36	16	129.7	2125.4	
	GAT3006SW1200	12	300	37.75	18	172.5	2219.4	

DESIGN DATA

TEMPERATURE: 700°F (370°C)
 PRESSURE: 300 PSI (2068 KPa)
 TEST PRESSURE: 450 PSI (3102 KPa)
 AXIAL MOVEMENT: 6" COMPRESSION (150 mm)

NOTE: ANCHOR LOAD =
 (MAX PSI X EFFECTIVE AREA) +
 (SPRING RATE X MOVEMENT)

MILITARY SPECS:

CONFORMS TO MIL-E-17813H AND ASTM-F-2934

CUSTOMER: _____

PROJECT: _____

ENGINEER: _____

REV.	DATE
	
2323 W. HUBBARD ST. CHICAGO, IL 60612 TEL: 312-738-3800 FAX: 312-738-0415 WWW.METRAFLEX.COM	
METRAFLEX METRAGATOR, 300 PSI, 6" AXIAL COMPRESSION, WELD ENDS	
DRAWN BY: DKISH	DATE: 6/1/2015
APPROVED: ZB	DATE: 6/2/2015
SCALE: N/A	DRAWING NUMBER: GAT3006SW