

360° High compressive strength calcium silicate insulation.

Completely assembled. Ready to be welded to pipe and bolted or welded to structure.

Model PAPI Pre-Insulated Anchor

High anchor loads. No metal to metal contact. Pre-insulated anchors deliver maximum insulation effectiveness and energy savings. Unique design and high compressive strength insulation allows this anchor to support working loads of up to 17,500 lbs. and test loads of up to 26,250 lbs.

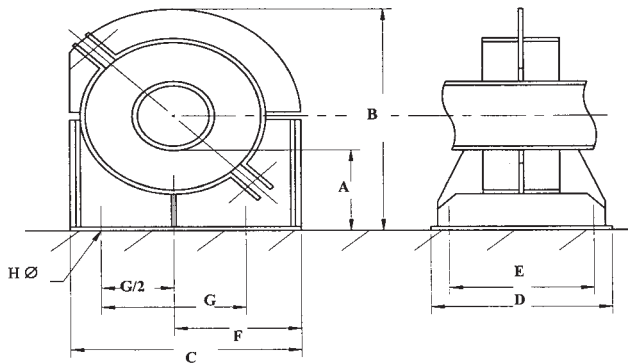

Anchor Hardware

- Available materials: Carbon Steel or Stainless Steel
- Power-coated finish (carbon steel only 2 mil)

Insulation insert

- 360° asbestos-free Xonolite Calcium Silicate - 900 PSI compressive strength
- K-Factor: .61 @ 400°F
- Meets ASTM C-533, C-585, C795, E-72 and E-84. Flame Spread -0-, Smoke developed -0-.
- All units include a vapor barrier jacket meeting ASTM D-744 and protection shield of galvanized or stainless steel

TOTAL QTY	PIPE SIZE	ANCHOR DIMENSIONS (INCHES)								WORKING LOADS LBS	NOTES
		A	B	C	D	E	F	G	H		
	1-1/2"	5.25	11.82	10.00	8.00	6.00	5.62	5	0.62	2,200	
	2"	5.12	11.93	10.00	8.00	6.00	5.62	5	0.62	2,200	
	2-1/2"	5.38	13.43	12.00	8.00	6.00	6.62	7	0.62	5,750	
	3"	5.12	13.49	12.00	8.00	6.00	6.62	7	0.62	5,750	
	4"	5.25	14.62	13.00	10.00	8.00	7.12	8	0.88	7,150	
	5"	5.25	15.72	14.00	10.00	8.00	7.69	10	0.88	9,100	
	6"	5.25	17.26	16.00	12.00	10.00	8.70	11	1.12	12,800	
	8"	6.50	20.64	18.50	12.00	10.00	9.83	13	1.12	17,500	

CUSTOMER _____

PROJECT _____

ENGINEER _____

ARCHITECT _____

PRO. OR P.O. NO _____

Metraflex
for pipes in motion
Chicago, IL

DESCRIPTION:

PRE-INSULATED ANCHOR

DRAWN BY:
JRR

DATE:
8/8/88

DRAWING NO:
DAPI F9J