

FROM  
**THE METRAFLEX CO.**  
CHICAGO, IL Ph: 312/738-3800 FAX: 312/738-0415

# THE CABLESPHERE!

The only rubber expansion joint completely assembled with control units - **No Field Labor!**

Compared to the standard control units  
**The Cablesphere :**

- ▶ Requires no field labor
- ▶ Can't be mis-installed
- ▶ Can't be forgotten
- ▶ Parts can't be lost
- ▶ Requires no adjustments
- ▶ Provides greater acoustical impedance

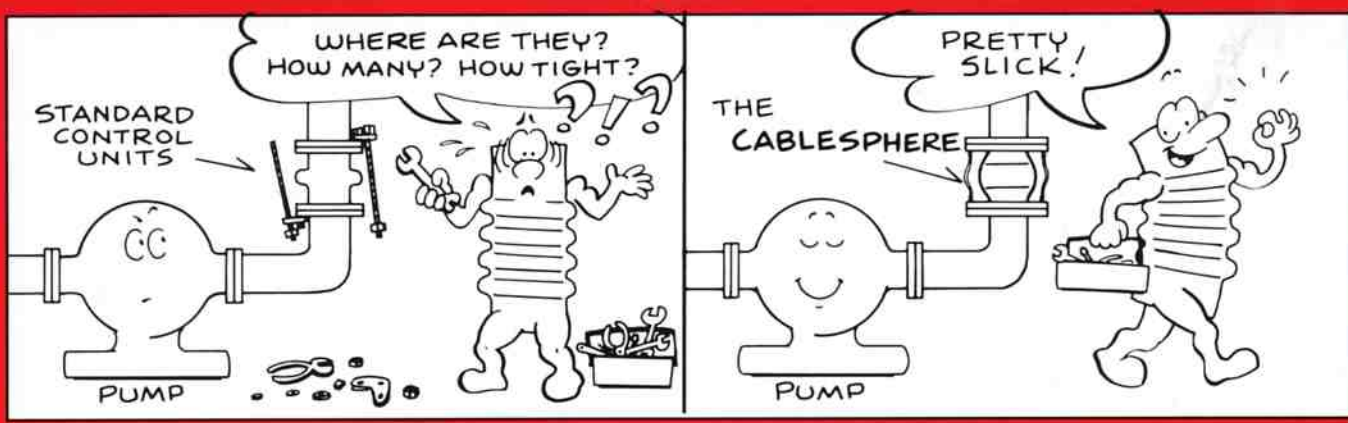

### THE CABLESPHERE:

The standard Cablesphere body is constructed of multiple layers of neoprene and bias-ply tire cord reinforcing. The spherical shape allows pressure to be exerted uniformly in all directions making an extremely strong joint. The cables are galvanized aircraft cables permanently affixed to the flanges. The cables are designed for the maximum text pressure of the joint. No adjustments can, or need be made to the cables. They are sized to prevent the joint from extending past its limit. The cablesphere is also available in a reducing, and a twin sphere style. Additional sizes and materials of construction are available.

### TYPICAL SPECIFICATION:

Flexible pump connectors/expansion joints shall be of the molded spherical type with integral cable restraints. Neoprene and nylon construction with internal steel wire, molded within the raised face ends, for added strength. Pressure rated for 225 psi at 230°F, with a minimum 4 to 1 safety factor. Flanges shall be one-piece, free-floating, class 150 galvanized plate steel type with permanently affixed control cables to prevent over-extension. Control cables shall be of the galvanized aircraft type, and be an integral part of the joint requiring no field adjustment. Connectors shall be "Cablesphere" as manufactured by The Metraflex Company, Chicago, IL.

# CABLESPHERE® Model MSRC 150# Flanged

This flexible joint should be installed the length shown on this drawing. Not intended for torsion. Cables are designed to allow full extension of the joint. Cables require no adjustment and should not be removed.

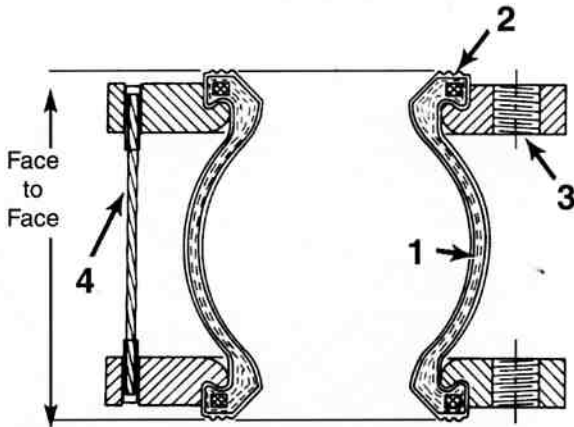
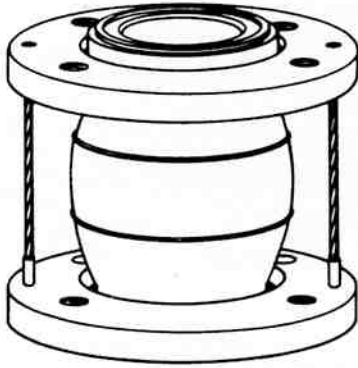

ITEM	NAME	MATERIAL
1	BODY	NEOPRENE & NYLON
2	WIRE	STEEL
3	FLANGE	PLATE STEEL
4	CABLE	GALVANIZED STEEL AIRCRAFT CABLE

MAXIMUM WORKING TEMPERATURE: 230° F.

OPTIONAL MATERIALS	
TUBE	COVER
<input type="checkbox"/> EPDM	<input type="checkbox"/> EPDM
<input type="checkbox"/> BUTYL	<input type="checkbox"/> BUTYL
<input type="checkbox"/> NITRILE	<input type="checkbox"/> NITRILE
<input type="checkbox"/> HYPALON	<input type="checkbox"/> HYPALON

### MOVEMENT CAPABILITY AND FORCES

Qty.	Size I.D. (In.)	Face to Face (In.)	Pressure P.S.I.G.	Vacuum (In.Hg.)	Compression (In.)	Approx. Force (Lbs.)	Elongation (In.)	Approx. Force (Lbs.)	Lateral (In.)	Approx. Force (Lbs.)	Angular (Degrees)	Weight (Lbs.)	No. Cables	No. Bolt Holes	Thread Size
2	6	6	225	16	1/2	55	1/8	73	1/2	55	15	8	2	4	5/8-11NC
2-1/2	6	6	225	16	1/2	102	1/8	68	1/2	97	15	13	2	4	5/8-11NC
3	6	6	225	16	1/2	136	1/8	115	1/2	108	15	14	2	4	5/8-11NC
4	6	6	225	16	5/8	145	1/8	242	1/2	275	15	18	2	8	5/8-11NC
5	6	6	225	16	5/8	172	1/8	296	1/2	308	15	23	2	8	3/4-10NC
6	6	6	225	16	5/8	293	1/8	563	1/2	484	15	28	2	8	3/4-10NC
8	6	6	225	16	5/8	372	1/8	587	1/2	688	15	40	4	8	3/4-10NC
10	8	8	225	16	3/4	398	1/4	455	3/4	781	15	68	4	12	7/8-9NC
12	8	8	225	16	3/4	390	1/4	356	3/4	842	15	96	4	12	7/8-9NC
14	10-1/2	10-1/2	125	16	1	N/A	1/4	N/A	7/8	N/A	15	105	8	12	1-1/8-Hole
16	10-1/2	10-1/2	125	16	1	N/A	1/4	N/A	7/8	N/A	15	120	8	16	1-1/8-Hole
18	10-1/2	10-1/2	125	16	1	N/A	1/4	N/A	7/8	N/A	15	125	8	16	1-1/4-Hole
20	10-1/2	10-1/2	125	16	1	N/A	1/4	N/A	7/8	N/A	15	145	8	20	1-1/4-Hole

CUSTOMER \_\_\_\_\_  
PROJECT \_\_\_\_\_  
ENGINEER \_\_\_\_\_  
ARCHITECT \_\_\_\_\_  
PRO. OR P.O. NO \_\_\_\_\_

*the Metraflex® company*  
CHICAGO ILLINOIS

DESCRIPTION:

**CABLESPHERE®**  
Patent #5273321

DRAWN BY:  
JO

DATE:  
2/99

DRAWING NO:  
MSRC-99