

NON-METALLIC EXPANSION JOINTS APPLICATION & DESIGN GUIDE



Metraflex
for pipes in motion

2323 W. HUBBARD ST. • CHICAGO, IL 60612 • 312-738-3800 • FAX 312-738-0415 • <http://www.metraflex.com>

How to Order Metraflex Non-Metallic Expansion Joints

Please Provide the Following Information (as a minimum):

1. **Size of Line:** Nominal Pipe Diameter
2. **System Application:** Flowing Media, Requirements
3. **Pressure or Vacuum:** Internal, External
4. **Temperature:** Operating, Ambient
5. **Movement:** Direction, Amount
6. **Need for Control Units:** Based on System Anchoring
7. **End Fittings:** ANSI, DIN, British Standard, Metric, etc.

This guide provides additional information on the details of choosing a joint for a given application. However, with the above information our engineers can choose a joint right for your needs.

Metraflex has been supplying industry with quality piping products for over 40 years. Our reputation for superior products and technical support sets us apart from our competition.

In addition to non-metallic expansion joints, **Metraflex** is a supplier of metallic expansion joints, braided hose, expansion loops, and other specialty piping products using bellows technologies. For more information or to order,

Contact us at:



(312) 738-3800

(312) 738-0415 Fax

or contact the representative
in your area - see back cover.

Non-Metallic Expansion Joints

Elastomer (rubber) and Teflon® expansion joints have been specified for many years to accommodate movement in piping runs and insure efficient systems. Elastomer joints are widely used to provide efficient ways to relieve movement stresses, reduce noise, isolate vibration, compensate for misalignment. Teflon joints are used with highly corrosive media, with glass piping, or in systems where space is at a premium.

Elastomeric expansion joints are fabricated from synthetic elastomers and fabric, and are often reinforced with metal. When operating temperatures and pressures exceed 250°F and 200 psig, respectively, rubber should not usually be considered an alternative to metallic expansion joints. Within these limits, elastomeric joints do offer advantages compared with metal joints, including:

1. **Cycle Life** - Many more cycles can be provided, and vibration fatigue is not a concern.
2. **Stress Corrosion** - They are chemically inert to most common corrosive elements.
3. **Resistance to Abrasion and Erosion** - They outlast metal joints in this respect.
4. **Resistance to External Damage** - With elastomer joints, accidental external blows do not cause damage.
5. **Space Requirements** - Metal joints require a considerably greater face-to-face dimensions.
6. **Acoustical Impedance** - They absorb a great deal of noise and vibration.
7. **Light Weight** - They are easy to handle and compact.
8. **Low Cost** - In general, they are less expensive than metal joints.

Teflon expansion joints also have certain advantages, which include:

1. **Chemical Resistance** - Molded and machined Teflon connectors are used in corrosive applications due to the inherent resistance of the material to a vast range of chemicals.
2. **Acoustical Impedance** - They absorb noise and vibration.
3. **Temperature Limits** - Teflon can withstand temperatures as high as 450° F and as low as -10° F.

Metraflex provides complete lines of non-metallic joints to best meet your needs. The following pages describe our products and their proper usage.

Table Of Contents

Metraflex Products

Metrasphere	page 4
Reducing Metrasphere	page 5
Cablesphere	page 6
Double Cablesphere	page 7
711 Wide Arch	page 8
100HT Standard Spool Type	page 9
Concentric Reducer	page 10
Flexible Rubber Pipe	page 11
Flexible Couplings	page 11
Teflon Expansion Joints	page 12

Installation

Anchoring	page 13
Control Units	page 13-14
Installation Instructions	page 15

Construction Details

Assembly Terminology	page 16
Control Units	page 17
Designs for Turbulence and Abrasion	page 17

Performance Characteristics

Temperature Class	page 18
Sound Limiting	page 18
Physical and Chemical Properties of Materials	page 18
Required Forces and Spring Rates	page 19

Terms and Conditions	page 20
-----------------------------------	----------------

Metraflex Quality Products

METRASPHERE

The **Metrasphere** is the most widely applied expansion joint/flexible connector in the industry today. It provides the greatest pressure, temperature and movement, at a very reasonable cost. The **Metrasphere's** resiliency also helps control pulsation shocks and noise transmission.

Constructed of EPDM* and nylon, the spherical shape allows pressure to exert itself uniformly in all directions, thus reducing the force exerted on pipe lines and equipment. Bias-ply tire cord provides strength, a high safety factor, and low force to move. Precision molding provides a dense, uniform carcass.

Solid plate steel flanges grip the sealing area and provide a fluid tight connection. All flanges are tapped or drilled to mate with 150# or 300# companion flanges. The tapped bolt holes and rotatable flanges make installation easy. The arch is self-cleaning, thus eliminating the need for filled arch when solids are present in the stream.

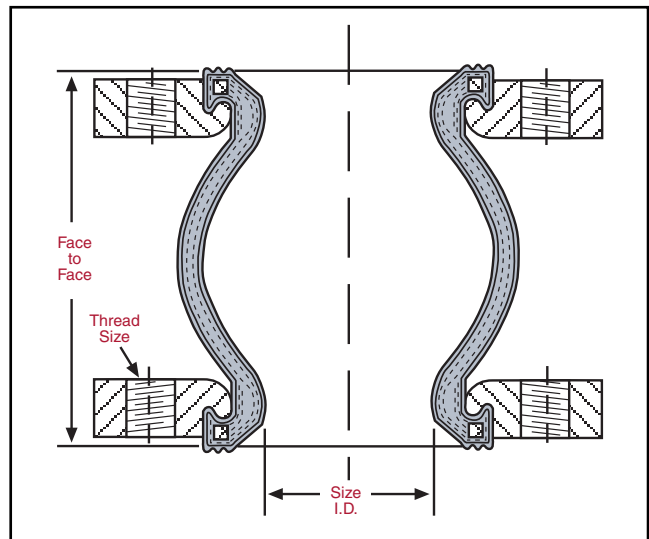

Control units required in unanchored applications
See page 17.

Joint Size I.D. (in.)*	FACE TO FACE (in.)		PRESSURE VS. TEMPERATURE			MOVEMENT CAPABILITY							THREAD SIZE (in.)	GROSS WT. (lbs.)
						Compression		Elongation (in.)		Lateral (in.)		Angular (Degrees)		
	Style O	Style R	170° F	200° F	220° F	Style O	Style R	Style O	Style R	Style O	Style R			
1	3-3/4	-	225	150	100	1/4	-	3/32	-	1/4	-	15	1/2-12NC	5
1 1/4	3-3/4	-	225	150	100	1/4	-	3/32	-	1/4	-	15	1/2-12NC	6
1 1/2	3-3/4	-	225	150	100	1/4	-	3/32	-	1/4	-	15	1/2-12NC	7
2	4-1/8	6	225	150	100	3/8	1/2	1/4	3/8	3/8	1/2	15	5/8-11NC	8
2 1/2	4-1/2	6	225	150	100	1/2	1/2	1/4	3/8	3/8	1/2	15	5/8-11NC	13
3	5-1/8	6	225	150	100	1/2	1/2	1/4	3/8	3/8	1/2	15	5/8-11NC	14
4	5-3/8	6	225	150	100	3/4	5/8	3/8	3/8	1/2	1/2	15	5/8-11NC	18
5	6-3/4	6	225	150	100	3/4	5/8	3/8	3/8	1/2	1/2	15	3/4-10NC	23
6	7-1/8	6	225	150	100	3/4	5/8	3/8	3/8	1/2	1/2	15	3/4-10NC	28
8	8-1/8	6	225	150	100	1	5/8	1/2	3/8	7/8	1/2	15	3/4-10NC	40
10	9-3/8	8	225	150	100	1	3/4	1/2	1/2	7/8	3/4	15	7/8-9NC	68
12	10-1/4	8	225	150	100	1	3/4	1/2	1/2	7/8	3/4	15	7/8-9NC	94
14	10-1/2	-	125	95	35	-	1	-	5/8	-	7/8	15	1-1/8-HOLE	105
16	10-1/2	-	125	95	35	-	1	-	5/8	-	7/8	15	1-1/8-HOLE	120
18	10-1/2	-	125	95	35	-	1	-	5/8	-	7/8	15	1-1/4-HOLE	125
20	10-1/2	-	125	95	35	-	1	-	5/8	-	7/8	15	1-1/4-HOLE	145

* Consult factory for special material such as Viton, Hypalon, Neoprene, Nitrile, etc. and for larger sizes or higher working pressures.

REDUCING METRASPHERE

The **Reducing Metrasphere** has all the benefits of the standard Metrasphere in a very competitive reducing connector. Making the transition to larger or smaller diameter piping at the pump saves space, time, and money.

Constructed of EPDM* and nylon, the spherical shape allows pressure to exert itself uniformly in all directions, thus reducing the force exerted on pipe lines and equipment. Bias-ply tire cord provides strength, a high safety factor, and low force to move. Precision molding provides a dense, uniform carcass.

Solid plate steel flanges grip the sealing area and provide a fluid tight connection. All flanges are tapped or drilled to mate with 150# or 300# companion flanges. The tapped bolt holes and rotatable flanges make installation easy. The arch is self-cleaning, thus eliminating the need for a filled arch when solids are present in the stream.

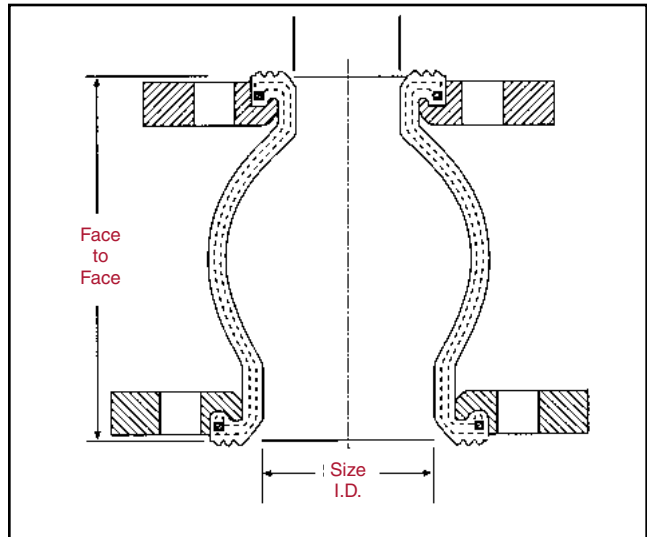

**Control units required in unanchored applications
See page 17.**

Joint Size I.D. (in.)*	FACE TO FACE (in.)	PRESSURE VS. TEMPERATURE			MOVEMENT CAPABILITY							
					AXIAL DEFLECTION							
		170° F	200° F	220° F	Comp. (in.)	Approx. Force (Lbs.)	Elong. (In.)	Approx. Force (Lbs.)	Lateral (In.)	Approx. Force (Lbs.)	Angular (Degrees)	Weight (Lbs.)
3 x 2	8	225	150	100	1/2	136	3/8	115	1/2	108	15	15
3 x 2-1/2	8	225	150	100	1/2	136	3/8	115	1/2	108	15	16
4 x 2	8	225	150	100	5/8	145	3/8	242	1/2	275	15	18
4 x 3	8	225	150	100	5/8	145	3/8	242	1/2	275	15	19
6 x 4	8	225	150	100	5/8	293	3/8	563	1/2	484	15	28
8 x 4	8	225	150	100	5/8	372	1/2	587	1/2	688	15	40
8 x 6	8	225	150	100	5/8	372	1/2	587	1/2	688	15	46
10 x 8	8	225	150	100	3/4	398	1/2	455	3/4	781	15	69

Metraflex Quality Products

CABLESPHERE®

The **Cablesphere** is the ultimate rubber expansion joint/flex connector. It has all the benefits of the Metrasphere (see previous page) with the added feature of pre-assembled control units. The concern as to whether the system is anchored and or guided is eliminated efficiently and cost effectively. The **Cablesphere** requires no field labor, control units can't be forgotten or mis-installed.



The standard **Cablesphere** body is constructed of multiple layers of EPDM* and bias-ply tire cord reinforcing. The spherical shape allows pressure to be exerted uniformly in all directions making an extremely strong joint. The cables are galvanized aircraft cable permanently affixed to the flanges. The cables are designed for the maximum test pressure of the joint. No adjustments can, or need be made to the cables. They are sized to prevent the joint from extending past its limit.

Please note: the elongation of the **Cablesphere** is purposely restricted compared to the Metrasphere. This is done to accommodate the 90% of the applications where the **Cablesphere** is installed as a pump connector and elongation is not desired.

* Viton, Hypalon, Neoprene, Buna-N, etc. for larger sizes or higher working pressures are also available.

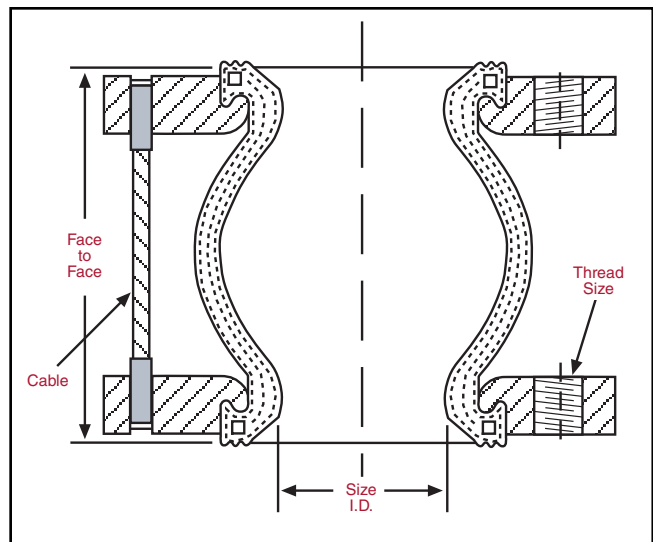

Joint Size I.D. (in.)*	FACE TO FACE (in.)	PRESSURE VS. TEMPERATURE			MOVEMENT CAPABILITY				SPRING RATE (lbs./in.)	EFF. AREA (lbs./sq.)	THREAD SIZE (in.)	GROSS WT. (lbs.)
		170° F	200° F	220° F	COMP. (in.)	ELONG (in.)	LATERAL (±in.)	ANGULAR (degrees)				
2	6	225	150	100	1/2	1/8	1/2	15	526	15	5/8-11NC	8
2 1/2	6	225	150	100	1/2	1/8	1/2	15	964	15	5/8-11NC	13
3	6	225	150	100	1/2	1/8	1/2	15	1480	15	5/8-11NC	14
4	6	225	150	100	5/8	1/8	1/2	15	812	15	5/8-11NC	18
5	6	225	150	100	5/8	1/8	1/2	15	1312	15	3/4-10NC	23
6	6	225	150	100	5/8	1/8	1/2	15	1336	15	3/4-10NC	28
8	6	225	150	100	5/8	1/8	1/2	15	1728	15	3/4-10NC	40
10	8	225	150	100	3/4	1/4	3/4	15	1426	15	7/8-9NC	68
12	8	225	150	100	3/4	1/4	3/4	15	1826	15	7/8-9NC	96

* For larger sizes, contact factory.

** Consult Factory for angular movement.

Patent# 5,273,321

Metraflex Quality Products

DOUBLE SPHERE & DOUBLE CABLESPHERE

The **Double Sphere and Double Cablesphere** are used exactly as their single sphere counterparts. However, they allow greater compression, elongation and angular movement. Its unique shape and longer length increases acoustic resistance and dampens hydraulic surge and shock.

Like the Cablesphere, the **Double Cablesphere** comes standard with cables which act as control units. This unique feature is invaluable in providing you with confidence that the joint was adequately specified. It also eliminates the need for control units.

Viton, Hypalon, Neoprene, Buna-N, etc. and for larger sizes are also available.



WITHOUT CABLES, CONTROL UNITS ARE REQUIRED IN UNANCHORED APPLICATIONS. SEE PAGE 17.

Joint Size I.D. (in.)*	FACE TO FACE (in.)	PRESSURE VS. TEMPERATURE			MOVEMENT CAPABILITY								SPRING RATE (lbs./in.)	EFF. AREA (lbs./sq.)	GROSS WT. (lbs.)
					COMPRESSION (in.)	Elongation (in.)		Lateral (in.)		ANGULAR (Degrees)					
		170° F	200° F	220° F		DOUBLE SPHERE	DOUBLE CABLESPHERE	DOUBLE SPHERE	DOUBLE CABLESPHERE	DOUBLE SPHERE	DOUBLE CABLESPHERE				
2	7	225	150	100	2	1-1/8	3/16	1-3/4	1	40	30	160	6	10	
2 1/2	7	225	150	100	2	1-1/8	3/16	1-3/4	1	40	30	310	10	13	
3	7	225	150	100	2	1-3/8	3/16	1-3/4	1	40	30	320	11	14	
4	9	225	150	100	2	1-3/8	1/4	1-1/2	1-1/2	35	30	450	20	15	
5	9	225	150	100	2	1-3/8	1/4	1-1/2	1-1/2	30	30	360	32	24	
6	9	225	150	100	2	1-3/8	1/4	1-1/2	1-1/2	30	30	760	43	33	
8	13	225	150	100	2-3/8	1-3/8	1/4	1-3/8	1-3/8	30	30	1030	66	48	
10	13	225	150	100	2-3/8	1-3/8	1/4	1-3/8	1-3/8	30	30	680	101	65	
12	13	225	150	100	2-3/8	1-3/8	1/4	1-3/8	1-3/8	20	30	950	154	76	

* For larger sizes, contact factory.

DoubleSphere Unions are used for connecting pipes and equipment where threaded union ends are preferred. They are made of EPDM and nylon and are resistant to ozone and aging. They also accommodate thermal movement and misalignment.



JOINT SIZE I.D. (in.)*	FACE TO FACE (in.)	PRESSURE (PSI) VS. TEMPERATURE		MOVEMENT CAPABILITY				SPRING RATE (lbs./in.)	EFF. AREA (in. sq.)	GROSS WT. (lbs.)
		170°F		COMPRES-SION (in.)	ELONGA-TION (in.)	LATERAL (in.)	ANGULAR (degrees)			
3/4	6-1/2	150		1-1/4	3/16	1	50	94	3	2
1	6-3/4	150		1-1/4	3/16	1	50	110	3	3
1-1/4	7	150		1-1/4	3/16	1	50	130	4	4
1-1/2	7-1/4	150		1-1/4	3/16	1	50	143	5	5
2	8-1/2	150		1-1/4	3/16	1	50	160	6	6
2-1/2	9	150		1-1/4	3/16	1	50	310	10	8

* For larger sizes, contact factory.

Metraflex Quality Products

711 - WIDE ARCH

The **711** differs from the standard spool type in a few ways. There is no metal reinforcing imbedded in the carcass, and pressure is contained by using an integral sleeve on the back-up flange. The arch is much wider than that of a conventional joint, which provides greater movement. It is also available with a filled arch that reduces movement by 50%. Flat face flanges integral with the body mate to 125/150# flanges.

Plastic and fiberglass pipe-
flat faced flanges and low spring rates, make the **711** ideal for these applications.

Standard tube and cover materials-
EPDM, or Chlorobutyl. Neoprene, Hypalon, Viton, Teflon available on request.

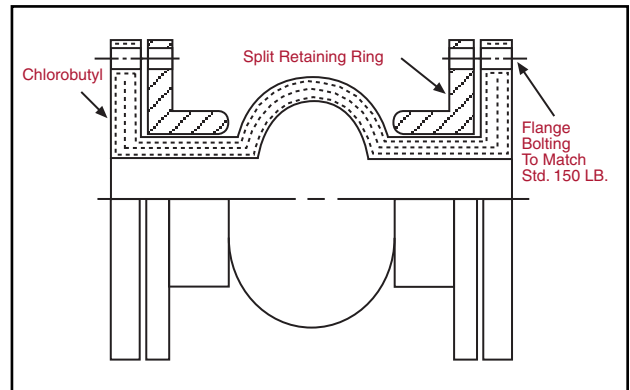

**Control units required in unanchored applications
See page 17.**

JOINT SIZE I.D. (in.)*	FACE TO FACE (in.)	PRESSURE/ VACUUM		TEMPERATURE (°F)	MOVEMENT CAPABILITY				SPRING RATE (lbs./in.)	EFF. AREA (in. sq.)	GROSS WT. (lbs.)
		(P.S.I.G.)	(in. Hg)		AXIAL		DEFLECTION				
					COMPRES-SION (in.)	ELONGA-TION (in.)	LATERAL (in.)	ANGULAR (degrees)			
2	6	150	10	230	1-3/4	3/4	3/4	35	450	11	5.5
2-1/2	6	150	10	230	1-3/4	3/4	3/4	30	425	14	7.5
3	6	150	10	230	1-3/4	3/4	3/4	30	420	17	8.5
4	6	150	10	230	1-3/4	3/4	3/4	25	240	29	10.0
5	6	150	10	230	1-3/4	3/4	3/4	25	430	39	12.5
6	6	150	10	230	1-3/4	3/4	1	20	345	52	16.5
8	6	150	10	230	1-3/4	3/4	1	20	730	80	22.0
10	8	150	10	230	1-3/4	3/4	1	15	870	114	34.0
12	8	150	10	230	1-3/4	3/4	1	15	930	157	45.0
14	8	130	10	230	2	7/8	1-1/8	12	1010	105	55.0
16	8	110	10	230	2	7/8	1-1/8	12	1190	259	64.0
18	8	110	10	230	2	7/8	1-1/8	9	1270	317	71.0
20	8	110	10	230	2	7/8	1-1/8	9	1460	379	82.0
24	10	100	10	230	2-1/4	1	1-1/8	9	1812	548	102.0
30	10	100	10	230	2-1/4	1	1-1/8	6	2264	848	140.0
36	10	90	10	230	2-1/4	1	1-1/8	5	2420	1194	190.0

* For larger sizes, contact factory.

SPOOL TYPE - STYLE 100HT

The Metraflex *Spool Type* expansion joint is constructed with high strength fabric and elastomer reinforced with metal rings. The flanges are integral with the body and utilize metal retaining rings. Standard flange drilling mates with 125/150# flanges.

The spool type joint can be made in custom non-standard lengths and with special flanges. Multiple arches are available to handle greater movements. The joints can also be custom made with a permanent offset to compensate for grossly misaligned piping. (A custom tooling charge may be required.)

Metraflex *Spool Type* joints may be supplied with a soft rubber arch filler to prevent the collection of solid materials in the arch, however this does result in a reduction of normal movement (see page 13).



SINGLE ARCH



TRIPLE ARCH

**Control units required in unanchored applications
See page 17.**

JOINT SIZE I.D. (in.)*	MINIMUM FACE-TO-FACE (in.)	PRESSURE/ VACUUM		TEMP-ERATURE (°F)	MOVEMENT CAPABILITY				SPRING RATE (lbs./in.)	EFF. AREA (in.sq.)	WT. (lbs.) WITH RET. RINGS
					COMPRES-SION (in.)	ELONGA-TION (in.)	LATERAL (in.)	ANGULAR (degrees)			
					1-ARCH	1-ARCH	1-ARCH	1-ARCH			
2	6	165	26	230	7/16	1/4	1/2	19	800	20	8
2-1/2	6	165	26	230	7/16	1/4	1/2	15	411	24	10
3	6	165	26	230	7/16	1/4	1/2	13	537	28	11
4	6	165	26	230	7/16	1/4	1/2	10	731	39	15
5	6	140	26	230	7/16	1/4	1/2	8	777	51	17
6	6	140	26	230	7/16	1/4	1/2	6	800	64	20
8	6	140	26	230	11/16	3/8	1/2	6	894	97	28
10	8	140	26	230	11/16	3/8	1/2	5	494	485	38
12	8	140	26	230	11/16	3/8	1/2	5	596	208	53
14	8	85	15	230	11/16	3/8	1/2	4	1400	254	67
16	8	65	15	230	11/16	3/8	1/2	4	1850	318	81
18	8	65	15	230	11/16	3/8	1/2	3	2110	374	88
20	8	65	15	230	13/16	7/16	1/2	3	2630	450	102
24	10	65	15	230	13/16	7/16	1/2	3	3160	658	128

* For larger sizes, contact factory.

Metraflex Quality Products

CONCENTRIC REDUCER

ECCENTRIC ALSO AVAILABLE
CONTACT FACTORY

The Metraflex *Concentric Rubber Reducer* connects unequal size pipes that share a common centerline. The reducer is sometimes also called a tapered expansion joint. These joints eliminate the need for metallic reducers and at the same time provide sound and vibration isolation and expansion compensation.

A high strength synthetic fabric is used to reinforce the body. Flanges are drilled to standard ANSI dimensions and all joints are provided with metal retaining rings.



STYLE 100C

**Control units
required in
unanchored
applications
See page 17.**

PIPE SIZE TO PIPE SIZE (in.)	MINIMUM FACE TO FACE (in.)	PRESSURE		TEM- PERATURE (°F)	MOVEMENT CAPABILITIES				WEIGHT W/RINGS (lbs.)
		PSI	HG		COMPRES- SION (in.)	ELONGA- TION (in.)	LATERAL (in.)	ANGULAR (degrees)	
2 x 1	6	165	26	230	.5	.25	.5	3°	8
2 x 1.5	6	165	26	230	.5	.25	.5	3°	8
2.5 x 1.5	6	165	26	230	.5	.25	.5	3°	10
2.5 x 2	6	165	26	230	.5	.25	.5	3°	11
3 x 1.5	6	165	26	230	.5	.25	.5	3°	11
3 x 2	6	165	26	230	.5	.25	.5	3°	12
3 x 2.5	6	165	26	230	.5	.25	.5	3°	13
4 x 2	6	165	26	230	.5	.25	.5	3°	15
4 x 2.5	6	165	26	230	.5	.25	.5	3°	16
4 x 3	6	165	26	230	.5	.25	.5	3°	18
5 x 3	6	140	26	230	.5	.25	.5	3°	17
5 x 4	6	140	26	230	.5	.25	.5	3°	18
6 x 2	8	140	26	230	.5	.25	.5	3°	18
6 x 2.5	6	140	26	230	.5	.25	.5	3°	19
6 x 3	6	140	26	230	.5	.25	.5	3°	19
6 x 4	6	140	26	230	.5	.25	.5	3°	20
6 x 4	8	140	26	230	.5	.25	.5	3°	24
6 x 5	6	140	26	230	.5	.25	.5	3°	26
8 x 3	6	140	26	230	.75	.375	.5	3°	26
8 x 4	6	140	26	230	.75	.375	.5	3°	28
8 x 4	8	140	26	230	.75	.375	.5	3°	30
8 x 5	6	140	26	230	.75	.375	.5	3°	31
8 x 6	6	140	26	230	.75	.375	.5	3°	33
8 x 6	8	140	26	230	.75	.375	.5	3°	34
10 x 5	8	140	26	230	.75	.375	.5	3°	36
10 x 6	8	140	26	230	.75	.375	.5	3°	38
10 x 8	6	140	26	230	.75	.375	.5	3°	40
10 x 8	8	140	26	230	.75	.375	.5	3°	43
12 x 6	8	140	26	230	.75	.375	.5	3°	48
12 x 8	6	140	26	230	.75	.375	.5	3°	50
12 x 8	8	140	26	230	.75	.375	.5	3°	53
12 x 10	8	140	26	230	.75	.375	.5	3°	59
14 x 8	8	85	15	230	.75	.375	.5	2°	65
14 x 10	8	85	15	230	.75	.375	.5	2°	68
14 x 12	8	85	15	230	.75	.375	.5	2°	70
16 x 10	8	65	15	230	.75	.375	.5	2°	78
16 x 12	8	65	15	230	.75	.375	.5	2°	81
16 x 14	8	65	15	230	.75	.375	.5	2°	89
18 x 12	8	65	15	230	.75	.375	.5	1°	88
18 x 14	8	65	15	230	.75	.375	.5	1°	90
18 x 16	8	65	15	230	.75	.375	.5	1°	99

Metraflex Quality Products

FLEXIBLE RUBBER PIPE

Metraflex *Flexible Rubber Pipe* is used primarily to suppress noise and vibration from pumps, chillers and other rotating equipment. It also inhibits electrolysis, water hammer and corrosion. It will accommodate minimum amounts of movement.

STYLE	MATERIAL	BACK UP RINGS	MAX. PRESS PSIG	MAX. TEMP.
400HT	Chlorobutyl & Nylon	Split	150	250 Deg. F.
450HT	Chlorobutyl & Nylon	Solid	250	250 Deg. F.

MINIMUM RECOMMENDED LENGTHS

DIAMETER	LENGTH
1-1/2" - 6"	12" LONG
8" - 10"	18" LONG
12" - 24"	24" LONG

STYLE 400T SWAGED MALE THREAD ENDS

DIAMETER	LENGTH
1/2" - 2-1/2"	12" LONG



FLEXIBLE COUPLINGS

Metra *201* requires no flanges or welding, which allows for quick disconnects. It is slipped over standard weight steel pipe and secured with T-bolt clamps. Construction is of neoprene and nylon with internal and external stainless steel rings to withstand pressure and vacuum. The maximum temperature is 225° F.

PIPE SIZE I.D. (in.)	LENGTH (in.)	JOINT SIZE I.D. (in.)	PRES-SURE/ VACUUM		MOVEMENT CAPABILITY			GROSS WT. (lbs.)
			(PSI)	(in. Hg)	COMP-PRESSION (in.)	ELONG-ATION (in.)	ANGULAR (degrees)	
2	7	2-3/8	75	20	1	1/2	10	1.6
2-1/2	7	2-7/8	75	20	1	1/2	10	1.8
3	7	3-1/2	75	20	1	1/2	10	2.0
4	7	4-1/2	75	20	1	1/2	10	2.4
5	7	5-5/8	75	20	1	1/2	10	2.9
6	7	6-5/8	75	20	1	1/2	10	3.4
8	7	8-5/8	75	20	1	1/2	10	4.3
10	7	10-3/4	75	20	1	1/2	10	5.1
12	7	12-3/4	75	20	1	1/2	10	6.7



TEFLON EXPANSION JOINTS

Molded of PTFE material for long life and extreme chemical resistance, the Metraflex **Teflon® Expansion Joints** are non-aging and have our shortest F/F dimension.

Ductile iron flanges with tapped bolt holes, integral steel limit bolts, and reinforcing rings enable this to absorb vibration and allows for thermal movement and misalignment in piping. All flanges are tapped to mate with 125/150# companion flanges. No gaskets needed.

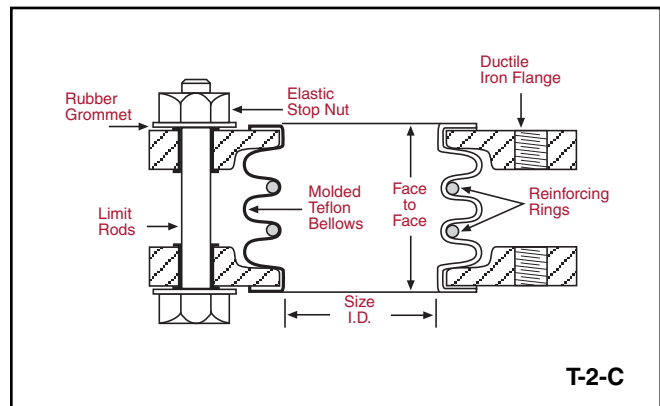
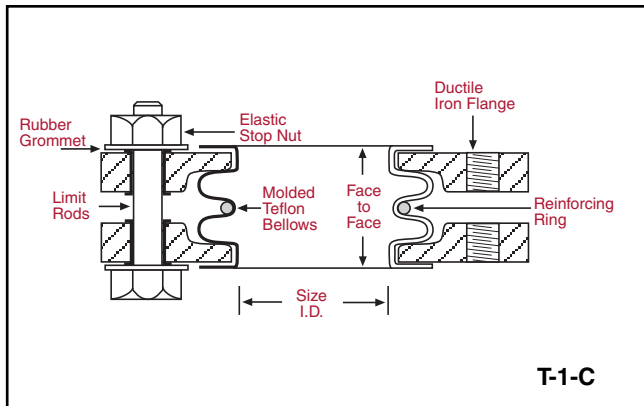

Joint Size I.D. (in.)*	FACE TO FACE (in.)	T-1-C TEFLON EXPANSION JOINTS							MAX. TEMP. FOR FULL VAC (°F)
		MAXIMUM AXIAL TRANSVERSE (±in.)	MAXIMUM OFFSET (±in.)	PRESSURE (PSI) VS. TEMPERATURE				GROSS WT. (lbs.)	
				70°F	200°F	300°F	400°F		
1	1-3/8	1/4	1/8	190	130	100	70	2	275
1-1/2	1-3/8	1/4	1/8	190	130	100	70	3	275
2	1-9/16	1/4	1/8	190	130	100	70	7	275
2-1/2	2-1/4	5/16	1/8	190	130	100	70	10	275
3	2-1/4	3/8	3/16	190	130	100	70	12	275
4	2-5/8	1/2	1/4	190	130	100	70	18	275
5	3-1/4	1/2	1/4	190	130	100	70	24	275
6	2-3/4	1/2	1/4	190	130	100	70	29	275
8	4	1/2	1/4	165	115	85	60	47	150
10	5-1/4	1/2	1/4	165	115	85	60	64	150
12	6	1/2	1/4	165	115	85	60	72	80

Joint Size I.D. (in.)*	FACE TO FACE (in.)	T-2-C TEFLON EXPANSION JOINTS							MAX. TEMP. FOR FULL VAC (°F)
		MAXIMUM AXIAL TRANSVERSE (±in.)	MAXIMUM OFFSET (±in.)	PRESSURE (PSI) VS. TEMPERATURE				GROSS WT. (lbs.)	
				70°F	200°F	300°F	400°F		
1	1-3/4	1/2	1/4	140	90	65	45	2	275
1-1/2	2	1/2	1/4	140	90	65	45	4	275
2	2-3/4	3/4	3/8	140	90	65	45	8	275
2-1/2	3-1/16	3/4	3/8	140	90	65	45	11	275
3	3-5/8	1	1/2	140	90	65	45	13	275
4	3-5/8	1	1/2	140	90	65	45	19	275
5	4	1	1/2	140	90	65	45	25	275
6	4	1-1/8	9/16	140	90	65	45	30	275
8	6	1-1/8	9/16	120	80	55	35	48	150
10	7	1-1/8	3/8	80	50	30	15	80	150
12	7-7/8	1-3/16	5/16	80	50	30	15	105	80

* For larger sizes, contact factory.

Installation

ANCHORING

Anchors. Figure 4 illustrates a simple piping system. You will notice that in all cases, solid anchoring is provided wherever the pipeline changes direction and that the expansion joints in that line are located as close as possible to those anchor points. In addition, following the expansion joints, and again as close as is practical, pipe guides are employed to prevent displacement of the pipeline. It should be pointed out that the elbows adjacent to the pump are securely supported by the pump base so that no piping forces are transmitted to the flanges of the pump itself. Anchors shown at the 90° and the 45° bend in the pipeline must be solid anchors designed to withstand the thrust developed in the line together with any other forces imposed on the system at this point.

Calculation of Thrust. When expansion joints are installed in the pipeline, the static portion of the thrust is calculated as a product of the area of the I.D. of the arch of the expansion joint times the maximum pressure (design or test) that will occur with the line. The result is a force expressed in pounds. Refer to Figure 1.

Branch Connection Anchors. Figure 2 is another illustration of the proper anchoring that should be provided in a line with a branch connection. The anchor shown at the tee and elbow connections must be designed to withstand both the thrust and any other forces imposed on the system at these points. Again emphasis is placed on the relative location of the joints, their anchoring points and the pipe guides.

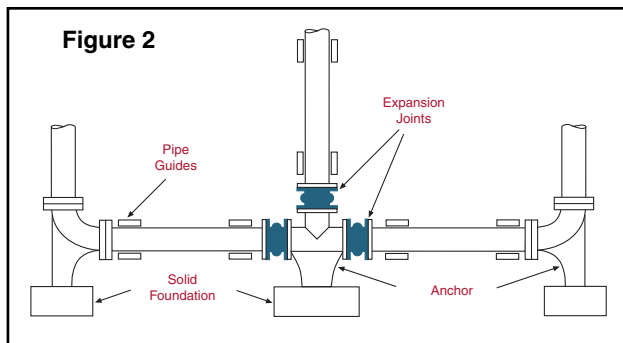
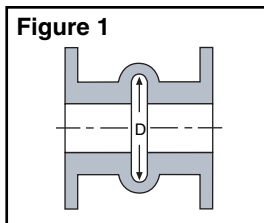

Typical Piping Layout Utilizing Expansion Joints And The Proper Use Of Anchors in Branch Locations

CONTROL UNITS

Definition and Purpose. A control unit assembly is a system of two or more control rods (tie rods) placed across an expansion joint from flange to flange to minimize possible damage to the expansion joint caused by excessive motion of the pipeline. This excessive motion could be caused by the failure of an anchor or some other piece of equipment in the pipeline. Figure 3 shows the proper assembly of an expansion joint with control unit details. The control rod assemblies are set at the maximum allowable expansion and/or contraction of the joint and will absorb the static pressure thrust developed at the expansion joint. When used in this manner, they are an additional safety factor, minimizing possible failure of the expansion joint and possible damage to the equipment. Control units will adequately protect the joints, but the user should be sure that pipe flange strength is sufficient to withstand total force that will be encountered. **The term “Control Unit” is synonymous with the term “Tie Rod” as defined by the standards of the Expansion Joint Manufacturer’s Association (EJMA).**

Use in Restraining the Piping System. Control units may be required to limit both extension and compression movements.

A. Extension. Control units must be used when it is not feasible in a given structure to provide adequate anchors in the proper location. In such cases, the static pressure thrust of the system will cause the expansion joint to extend to the limit set by the control rods which will then preclude the possibility of further motion that would over-elongate the joint. Despite the limiting action that control rods have on the joint, they must be used when proper anchoring cannot be provided. It cannot be emphasized too strongly that rubber expansion joints, by virtue of their function, are not designed to take end thrusts and, in all cases where such are likely to occur, proper anchoring is essential. If this fact is ignored, premature failure of the expansion joint is a foregone conclusion.

B. Compression. Pipe sleeves can be installed over the control rods. The purpose of the sleeve is to prevent excessive compression in the expansion joint. The length of this pipe sleeve should be such that the expansion joint cannot be compressed beyond the maximum allowable compression figure stated by the manufacturer. See Figure 3.

Note: Some of this information has been taken from the Fluid Sealing Associations Handbook on Non-Metallic Expansion Joints.

Installation

CONTROL UNITS (continued)

Illustration of the Use of Control Rods. Figure 4 demonstrates the type of piping connections that must be used in the event it is impossible to employ anchoring. The anchor point at the upper 90° elbow in the discharge line has been eliminated. In this situation, it is necessary to employ properly designed control units with the joints located in this non-anchored line. Without the use of these control units, the pipeline between the pump and the anchor, at the 45° bend, would be severely displaced due to elongation in the flexible rubber expansion joint. This elongation would proceed until the joints rupture. The use of control units in this case permits expansion of the pipeline in both the vertical and horizontal direction between the pump and the anchor, at the 45° bend. However, it does preclude the possibility of contraction in these respective lines as the further extension of the expansion joint is impossible because of the control units.

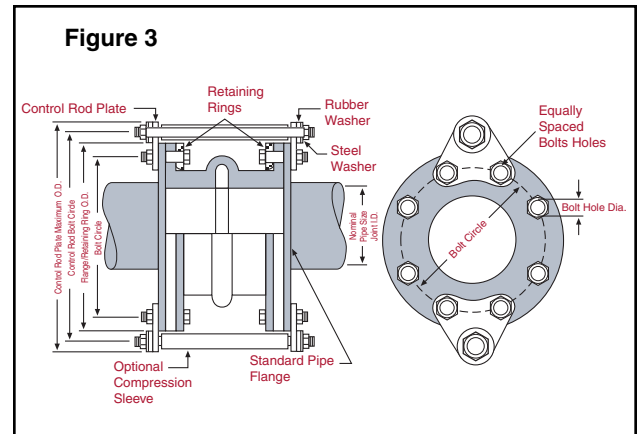

Expansion Joint With Assembly/Installation Of Control Unit Components

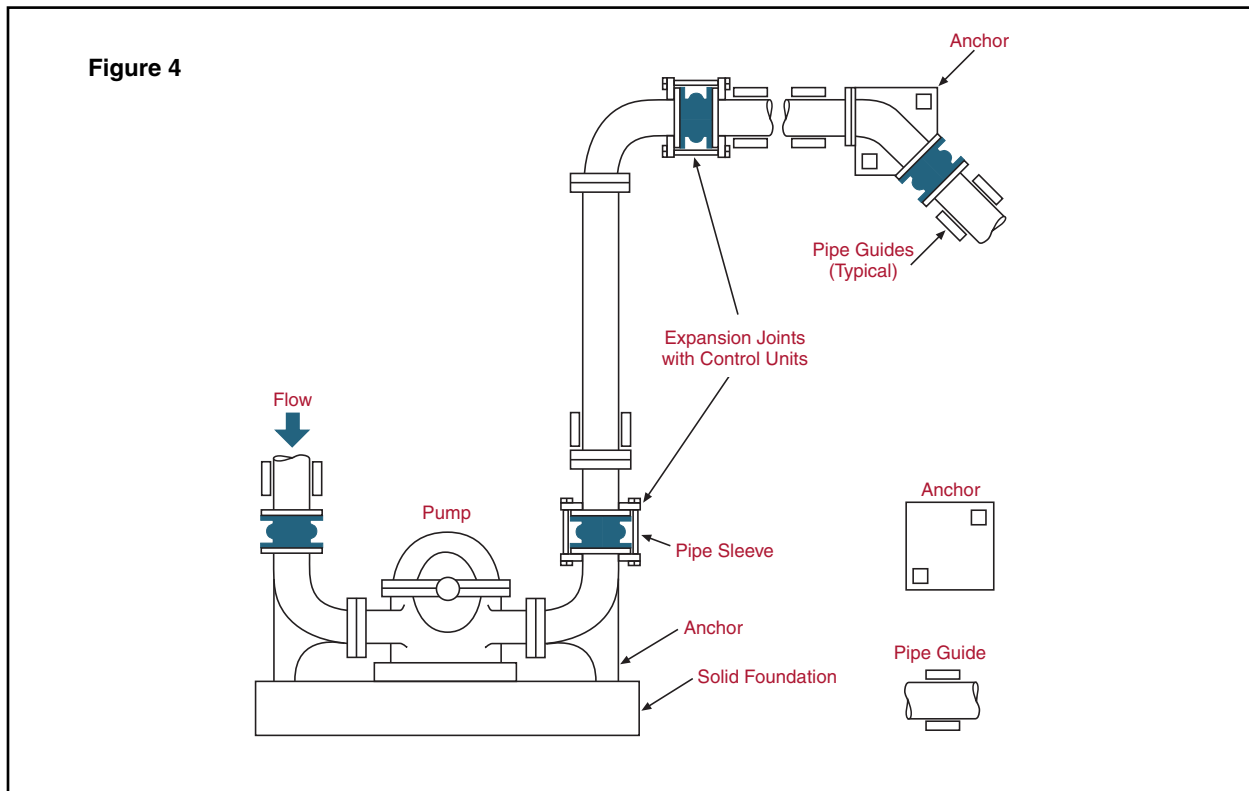

Typical Piping Layout Utilizing Expansion Joints When Equipment And Piping Are Properly Anchored

Note: Some of this information has been taken from the Fluid Sealing Associations Handbook on Non-Metallic Expansion Joints.

Installation

INSTALLATION INSTRUCTIONS

Joints with solid steel floating flanges (Metrasphere Cablesphere and Double Cablesphere)

1. Install at face to face dimension shown on drawing/catalog. Installation at longer lengths or between flanges that are not parallel can lead to failure. Under no circumstance are flange bolts to be used to stretch the sphere into contact with a mating flange.
2. Elastomer expansion joints may be bolted to either flat or standard raised face steel flanges. **DO NOT** use gaskets between the sphere and the flange surface.
3. Do not bolt directly to another component with an elastomer face. If you must bolt directly to a grooved adapter (Victaulic®) flange, you must use a solid, **FULL-FACE** metallic or phenolic insert ring. If using a phenolic ring, exercise caution in tightening to avoid cracking the ring.
4. Using plated steel washers between the nut and the flange is recommended. Use a torque wrench and the criss-cross method to apply torque to the nuts. First, uniformly torque the nuts to approximately 60% of the minimum torque. Ensure that the gap between the flanges is even around the flange. Then complete the tightening process. The gap between the flanges must be uniform when finished.
5. If bolt threads are facing the joint, trim length of bolts so they do not extend past nut more than 1/8" to avoid any contact with joint.
6. For piping that is not positively anchored, use control rods. Control rods are to be adjusted to provide movement that is less than or equal to the recommended extension. For systems with negative pressures, the control rods must have additional nuts installed between the floating flanges to prevent over-compression.
7. Do not paint or insulate the joint, except when Hypalon is applied as a UV protectant. When insulation is used over a pipeline adjacent to an expansion joint, the insulation should be brought up to the pipe flanges but not continued over and around the expansion joint. Covering a joint with insulation makes it very difficult and potentially hazardous to detect flange leaks which might otherwise be corrected by simply tightening flange bolts. Insulation could also lead to premature failure of the elastomer.

Joints with integral full faced rubber flanges (Spool Type and 711)

1. Before installation, check the interior, exterior and flange faces of the expansion joint for cuts or gouges.
2. Install at the face to face dimension shown on the drawing. Make sure the mating flanges are clean and are standard steel flat faced, or no more than the 1/16" raised face type. **Do Not Use Gaskets.**
3. Do not bolt directly to another component with an elastomer face or to a specialty flange such as the Victaulic® type without inserting a solid full face metallic gasket.
4. Cross tighten the bolts using sufficient torque to cause the O.D. of the rubber flange to bulge between the retaining rings and the mating flange. **NOTE - Due to rubber's tendency to relax after initial tightening, it is necessary to retighten the flange bolts, typically within 1 week of initial installation.**
5. If bolt threads are facing the joint, trim the length of the bolts so they do not extend past the nut more than 1/8" to avoid contact with the joint.
6. Washers must be used at the split in the retaining rings.
7. **For piping that is not anchored control rods must be used.** (See the previous sections for a complete discussion of anchoring and guiding).
8. Do not paint or insulate joints without consulting factory.

Additional Tips

- A. Storage** - Ideal storage is a warehouse with a relatively dry, cool location. Store flange face down on a pallet or wooden platform. Do not store other heavy items on top of an expansion joint. Ten year shelf-life can be expected with ideal conditions. If storage must be outdoors joints should be placed on wooden platforms and should not be in contact with the ground. Cover with a tarpaulin.
- B. Large Joint Handling** - Do not lift with ropes or bars through the bolt holes. If lifting through the bore, use padding or a saddle to distribute the weight. Make sure cables or forklift tines do not contact the rubber. Do not let expansion joints sit vertically on the edges of the flanges for any period of time.
- C.** It is acceptable (but not necessary) to lubricate the expansion joint flanges with a thin film of graphite dispersed in glycerin or water to ease disassembly at a later time.

Note: Some of this information has been taken from the Fluid Sealing Associations Handbook on Non-Metallic Expansion Joints.

Construction Details

ASSEMBLY TERMINOLOGY

A Standard Spool Type Expansion Joint cross section is illustrated to show construction details typical of elastomer joints. Additional details for the other non-metallic joints are provided with the product descriptions.

Tube: A seamless, fluid tight tube that extends to the outside edges of both flanges. The tube can be designed to cover service conditions for chemicals, petroleum, sewage, gases and abrasive materials.

Carcass: The flexible and supporting fabric and elastomer member between the tube and cover.

Carcass Reinforcing: Metal rings or wire imbedded in the carcass that strengthen the joint.

Cover: The surface of the joint is formed from synthetic rubber to protect the joint from outside damage. Special polymers can be supplied to resist chemicals, oils, sunlight, acid fumes or ozone.

Integral Flange: Smooth full faced rubber flanges provide a tight seal without gaskets. All units are available with standard or special drillings.

Retaining Rings: Steel or ductile iron are standard with all spool type expansion joints. They provide a metal backing surface for the rubber flange to allow uniform sealing against the mating flange.

Arch: The arch allows the movement for expansion joints. For more movement, multiple arch units are available. Arches can also be filled to prevent sediment build-up.

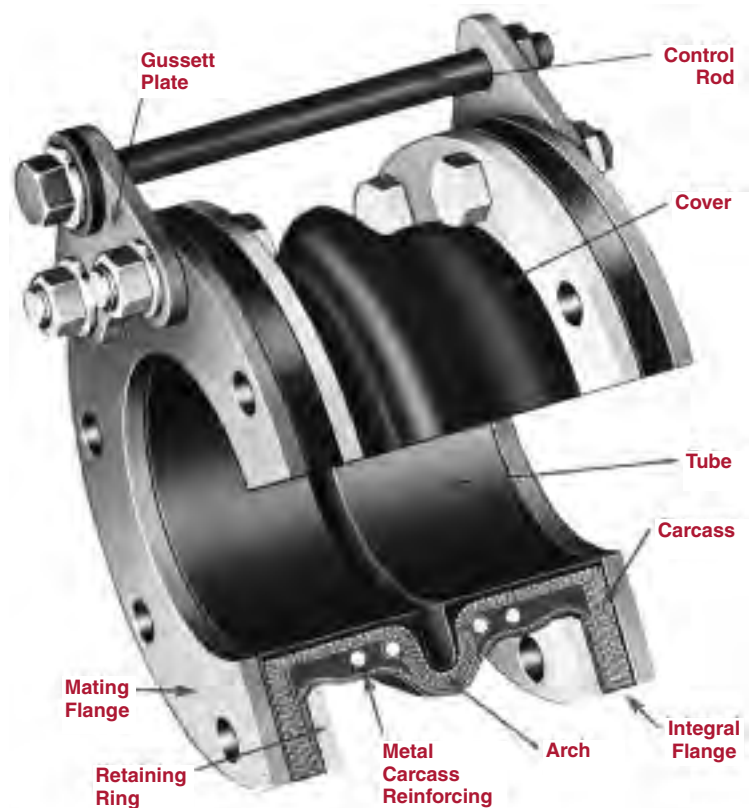

CONTROL UNIT DIMENSIONS AND RATINGS									
JOINT SIZE I.D. (in.)*	GUSSET PLATE THICKNESS (in.)	ROD DIAMETER (in.)	MAXIMUM PRESSURE (PSI)		JOINT SIZE I.D. (in.)*	GUSSET PLATE THICKNESS (in.)	ROD DIAMETER (in.)	MAXIMUM PRESSURE (PSI)	
			2-RODS	3-RODS				2-RODS	3-RODS
2	3/8	5/8	200	—	10	3/4	7/8	140	190
2-1/2	3/8	5/8	200	—	12	3/4	1	140	190
3	3/8	5/8	200	—	14	3/4	1	85	130
4	3/8	5/8	200	—	16	3/4	1-1/8	65	110
5	3/8	5/8	200	—	18	3/4	1-1/8	65	110
6	1/2	5/8	140	200	20	3/4	1-1/8	65	110
8	1/2	3/4	140	190	24	1	1-1/4	65	100

* For larger sizes, contact factory.

Construction Details

CONTROL UNITS (TIE RODS)

Unrestrained, most elastomer joints will extend when pressurized. It is preferable to anchor the system, however, when anchoring is not desirable or practical, control units must be used.

Gusset plates are bolted behind the mating flanges and control rods are used between them to limit extension of the joint. The number of rods required depends on the joint size and operating pressure of the system.

See page 12 for Dimensions and Ratings.

Standard control units are not required for those cablesphere models supplied with cables. The cabling acts as the control unit.

For more information on control units, see page 13.

DESIGNS FOR REDUCTION OF TURBULENCE AND ABRASION

The Standard Spool Type joint may be modified to reduce possible turbulence and to prevent the collection of solid materials that may settle from the process fluid.

Filled Arch Type: The spool joints may be supplied with a bonded-in-place soft rubber filler to provide a smooth interior bore. Filled arch joints also have a seamless tube so the arch filler cannot be dislodged during service. Filled arches, built as an integral part of the carcass, decrease the flexibility of the joint and should be used only when necessary. Movements of expansion joints with filled arches are limited to 50% of the normal movements of comparable size expansion joints with unfilled (open) arches.

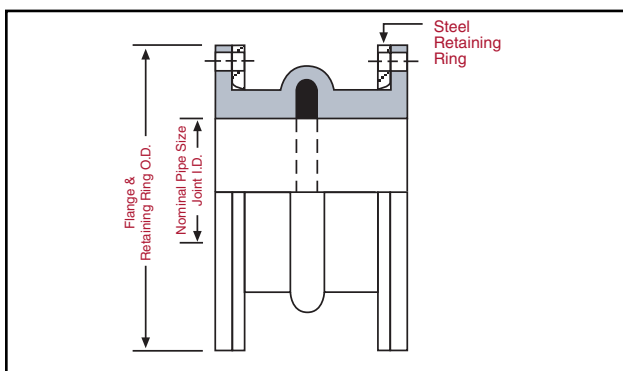

Single Arch Type Expansion Joint With Filled Arch

Note: Some of this information has been taken from the Fluid Sealing Associations Handbook on Non-Metallic Expansion Joints.

LINERS

Drop-In, Replaceable Elastomeric Type: A separate flanged liner, dimensioned to the I.D. of the expansion joint, can provide the same advantages as the Filled Arch Type; except movements are not reduced. Not recommended for vacuum applications.

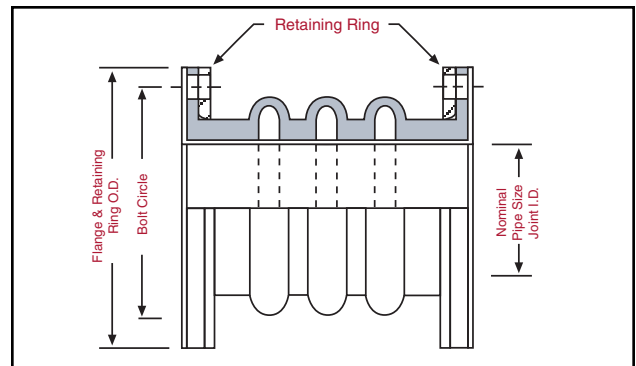

Replacement Liner Type Expansion Joint

“Top Hat” Liner: This product consists of a sleeve extending through the bore of the expansion joint with a Van Stone or a full face flange on one end. Constructed of hard rubber, metal or TFE; it reduces frictional wear of the expansion joint and provides smooth flow, reducing turbulence. This type sleeve should not be used where high viscosity fluids, such as tars, are being transmitted. These fluids may cause “packing-up or caking” of the arch area, which reduces movements and in turn may cause premature expansion joint failure. Baffles are rarely required on rubber expansion joints.

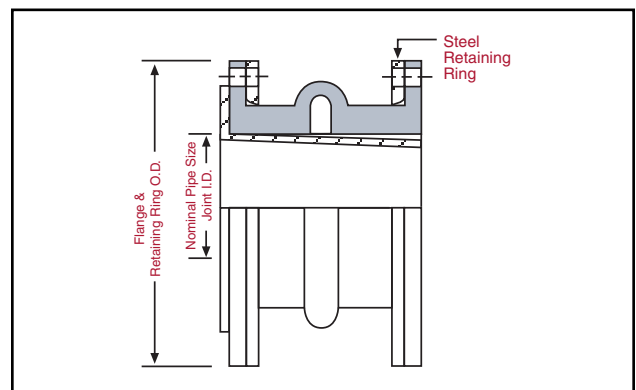

Top Hat Liner

Performance Characteristics

TEMPERATURE CLASS OF MATERIALS - Table I

TYPE OF ELASTOMER	CLASS
Gum Rubber	Std. I
Natural Rubber	Std. I
SBR/GRS/Buna-S	Std. I
Neoprene	Std. II
Buna-N/Nitrile	Std. II
Hypalon	Std. II
Butyl	Std. II
Chlorobutyl	Std. III
EPDM	Std. III
Viton/Fluorel	Std. III
Silicone	Std. III
Teflon/TFE/FEP	Std. III

- Standard Class I - Recommended up to 180°F
 Standard Class II - Recommended up to 230°F
 Standard Class III - Recommended for over 230°F

SOUND LIMITING - Table II

MATERIAL	SOUND VELOCITY In/sec.	DENSITY lbs./in.3	ACOUSTICAL IMPEDANCE lbs./in.2 sec.	RELATIVE IMPEDANCE
Steel	206,500	0.283	58,400	500.0
Copper	140,400	0.320	45,000	425.0
Cast Iron	148,800	0.260	38,700	365.0
Lead	49,800	0.411	20,400	190.0
Glass	216,000	0.094	20,300	190.0
Concrete	198,000	0.072	14,200	134.0
Water	56,400	0.036	2,030	19.0
Pine	132,000	0.0145	1,910	18.0
Cork	19,200	0.0086	165	1.6
Rubber	2,400	0.0442	106	1.0

Acoustical impedance is defined as the product of material density times velocity of sound in that material. In acoustical systems, low impedance corresponds to low sound transmission. Relative impedance is based on Rubber = 1.0

PHYSICAL AND CHEMICAL PROPERTIES OF MATERIALS - Table III

Rating Scale Code:

- 7 - Outstanding
 6 - Excellent
 5 - Very Good
 4 - Good
 3 - Fair to Good
 2 - Fair
 1 - Poor to Fair
 0 - Poor
 X - Contact Factory

COMMON NAME	MATERIAL DESIGNATION		ELASTOMER PHYSICAL AND CHEMICAL PROPERTIES COMPARISON																															
			WATER CHEMICAL	ANIMAL & VEG. OIL	ALKALI, CONC.	ALKALI, DILUTE	OIL & GASOLINE	LACQUERS	OXYGENATED HYDRO.	AROMATIC HYDRO.	ALIPHATIC HYDRO.	ACID, COND.	ACID DILUTE	SWELLING IN OIL	RADIATION	WATER ABSORP	ELE. INSULATION	DIELECTRIC STR.	TENSILE STRENGTH	COMP. SET	REBOUND-COLD	REBOUND-HOT	DYNAMIC	IMPERMEABILITY	ABRASION	TEAR	FLAME	COLD HEAT	OXIDATION	SUNLIGHT WEATHER	OZONE			
Chemical Group Name	ANSI/ASTM D1418-77	ASTM D-2000 D1418-77																																
NEOPRENE	CR	B C	4	3	4	0	4	4	0	1	2	3	4	6	4	5	4	3	5	4	2	4	5	2	4	5	4	4	4	5	5	6	5	
Chloroprene		B E																																
GUM RUBBER	NR	AA	5	3	X	X	X	0	0	4	0	0	3	3	0	6	5	5	6	6	4	6	6	6	2	7	5	0	5	2	4	0	2	0
Polysoprene, Synthetic																																		
NATURAL RUBBER	IR	AA	5	3	X	X	X	0	0	4	0	0	3	3	0	6	5	5	6	6	4	6	6	2	6	5	0	5	2	4	0	2	0	
Polysoprene, Synthetic																																		
BUTYL	IIR	AA	5	6	5	4	4	0	3	4	0	0	4	6	0	4	5	5	5	4	3	0	5	2	6	4	4	0	4	5	6	5	5	6
Isobutene-Isoprene																																		
CHLOROBUTYL	CIIR	AA	5	6	5	4	4	0	3	4	0	0	4	6	0	4	5	5	5	4	3	0	5	2	6	4	4	0	4	5	6	5	5	6
Chloro-Isobutene-Isoprene		BA																																
BUNA-N/NITRILE	NBR	B E	4	3	5	0	4	5	2	0	4	6	4	4	5	5	4	1	0	5	5	4	4	5	4	4	3	0	3	4	4	0	2	2
Nitril-Butadiene		B K X H																																
SBR/GRS/BUNA-S	SBR	AA	5	3	X	2	4	0	0	4	0	0	3	3	0	6	5	5	4	5	4	4	4	4	2	5	3	0	5	3	2	0	2	0
Styrene-Butadiene																																		
HYPALON*	CSM	C E	5	6	4	4	4	4	3	1	2	3	4	6	4	5	4	3	5	2	2	2	4	2	4	4	3	4	4	4	6	7	6	7
Chloro-Sulfonyl-Polyethylene																																		
VITON*/FLUOREL**	FKM	HK	5	6	6	0	4	6	1	0	6	6	6	5	6	5	5	3	5	5	6	2	4	5	5	5	2	6	2	7	7	7	7	
Fluorocarbon Elastomer																																		
EPDM	EPR	BA	5	6	5	6	6	0	3	6	0	0	4	6	0	7	6	6	7	5	4	6	6	5	4	5	4	0	5	6	6	7	6	7
Ethylene-Propylene-Diene-Terpolymer		CA DA																																
SILICONE	SI	G E	5	5	5	0	2	X	0	2	0	0	2	6	2	6	6	6	4	0	3	6	6	0	2	0	2	2	6	7	6	6	6	6
TEFLON*/TFE/FEP	AFMU		7	7	7	7	7	7	7	7	7	7	7	7	7	3	7	X	X	X	X	X	X	X	X	X	X	X	X	X	X	X	X	X
Fluoro-Ethylene-Polymers																																		

Note: This listing is only a general guide. Specific elastomer compounds produced by member manufacturers may have different properties. For additional information, see "Technical Handbook Properties of Chemical Compatibilities and Elastomers for Seals." Published by Fluid Sealing Association, 2017 Walnut Street Philadelphia, PA 19103. * Registered trademark of E. I. DuPont de Nemours & Co., Inc., ** Registered trademark of 3M Companies

Note: Some of this information has been taken from the Fluid Sealing Associations Handbook on Non-Metallic Expansion Joints.

Performance Characteristics

DETAILED SPOOL TYPE SPRING RATES - Table IV

The spring rate is defined as the force in pounds required to deflect an expansion joint one inch in compression and elongation or in a lateral direction. For angular movement the spring rate is the force needed in foot-pounds to deflect the expansion joint one degree.

NOMINAL PIPE SIZE EXPANSION JOINT	SPRING RATES			
	FORCE LBS. FOR 1" COMPRESSION MOVEMENT	FORCE LBS. FOR 1" EXTENSION MOVEMENT	FORCE LBS. FOR 1" LATERAL DEFLECTION	FORCE FOOT LBS. FOR 1" ANGULAR MOVEMENT
1/4*	-	-	-	-
3/8*	-	-	-	-
1/2*	133	172	174	.006
3/4*	199	256	262	.02
1*	235	304	350	.04
1-1/4*	294	383	438	.1
1-1/2*	353	459	524	.15
2	423	552	700	.3
2-1/2	530	689	762	.5
3	635	828	824	.8
3-1/2	742	965	888	1.3
4	848	1104	952	1.9
5	1058	1376	1092	3.7
6	1271	1652	1234	6.4
8	1412	1837	1506	12.7
10	1766	2296	1618	24.2
12	2118	2755	1896	42.1
14	1853	2411	2234	19.2
16	2118	2755	2572	76
18	2382	3101	2840	106
20	2649	3440	3176	152
22	2913	3785	3296	205
24	3178	4130	3412	274
26	3060	3980	3658	292
28	3296	4286	3904	382
30	3532	4594	4150	437
32	3769	4899	4876	555
34	4002	5602	5602	645
36	4238	5512	6328	844
38	4475	5818	6502	943
40	4708	6124	6676	1042
42	4452	5783	6846	1163
44	4664	6057	7142	1270
46	4870	6339	7436	1680
48	5087	6608	7732	1825
50	5300	6884	8024	1968
52	5512	7166	8314	2138
54	5724	7435	8606	2308
56	5936	7717	8896	2464
58	6148	7992	9184	3310
60	6360	8268	9472	3537
66	6996	9095	10216	4288
72	7632	9922	10954	5681
78	8268	10748	11902	7022
84	8904	11575	12850	8641
96	10176	13228	14750	13441
102	10812	14056	15700	16967
108	11448	14883	16652	21855
120	12720	16537	18550	29871
132	13992	18190	20288	33547
144	15264	19843	22026	42902

*Items are normally furnished with "Filled Arch" construction.

Notes:

1. Based on zero pressure conditions and room temperature in the pipe line.
2. To calculate the approximate Spring Rates for Multiple Arch Joints, divide the single arch values by the number of arches.
3. The lateral and angular Spring Rates are based on proportional values from the FSA Handbook.

Note: Some of this information has been taken from the Fluid Sealing Associations Handbook on Non-Metallic Expansion Joints.

Terms and Conditions

1. All quotations are subject to approval, acceptance and correction at the home office. Any errors in quotations resulting in orders will be corrected and re-submitted to the customer for their acceptance or refusal.

No prices may be made up from information other than that shown in the tables.

2. All prices are F.O.B. factory, Chicago, Illinois, are are quoted exclusive of any taxes.

Shipments boxed for trans-ocean export add 10% to total trade price.

Terms: Net 30 days from date of invoice.

3. Cancellation or alteration of an order or return of any product by Buyer may not be made without advance written consent of manufacturer and shall be subjected to a cancellation charge.

A 20% minimum restocking charge shall be placed on any returned goods.

4. We will not be responsible for delays in shipping due to conditions beyond our control such as strikes, fires, or accidents.

5. Any claims for shortages or damaged products must be made in writing within 10 days after receipt of shipment.

6. Prices subject to change without notice.

Design and Dimensional Specifications

The products illustrated reflect the design characteristics at time of printing.

Metraflex reserves the right to change dimensions, materials, or methods of construction without notice. Please contact the factory for certified prints (exact dimensions) when necessary.

Limited Warranty

All products are warranted to be free of defects in material and workmanship for a period of one year from the date of shipment, subject to the limitations below.

If the purchaser believes a product is defective the purchaser shall: (a) Notify the manufacturer, state the alleged defect and request permission to return the product. (b) If permission given, return the product with transportation prepaid. If the product is accepted for return and found to be defective, the manufacturer will, at its discretion, either repair or replace the product F.O.B. factory, within 60 days of receipt, or refund the purchase price. Other than to repair, replace or refund as described above, purchaser agrees that manufacturer shall not be liable for any loss,

costs, expenses or damages of any kind arising out of the product, its use, installation or replacement, labeling, instructions, information or technical data of any kind, description of product or use, sample or model, warnings or lack of any of the foregoing. NO OTHER WARRANTIES, WRITTEN OR ORAL, EXPRESS OR IMPLIED, INCLUDING THE WARRANTIES OF FITNESS FOR A PARTICULAR PURPOSE AND MERCHANTABILITY, ARE MADE OR AUTHORIZED. NO AFFIRMATION OF FACT, PROMISE, DESCRIPTION OF PRODUCT OF USE OR SAMPLE OR MODEL SHALL CREATE ANY WARRANTY FROM THE MANUFACTURER, UNLESS SIGNED BY THE PRESIDENT OF MANUFACTURER. These products are not manufactured, sold or intended for personal, family or household purposes.



• METAL BELLOWS EXPANSION JOINTS



• GUIDES, SLIDES AND ANCHORS

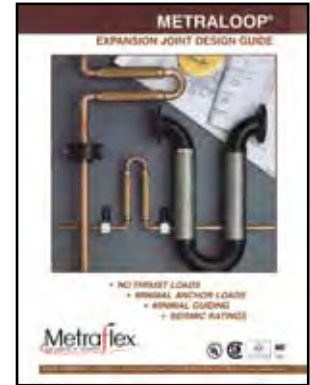

• EXPANSION LOOPS



• FLEXIBLE METAL HOSE



• SILENT CHECK VALVES



• METRAGATOR EXPANSION JOINTS



• CAST IRON STRAINERS

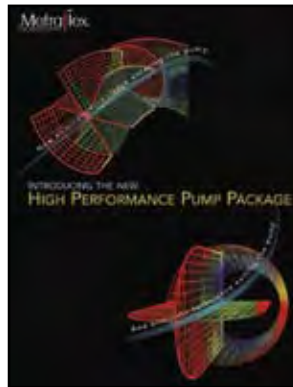

• HIGH PERFORMANCE

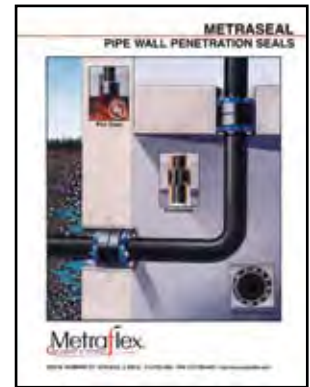

• METRASEAL



Call or write for information on any of these other **METRAFLEX PRODUCTS**

2323 W. HUBBARD ST. • CHICAGO, IL 60612 • 312-738-3800 • FAX 312-738-0415 • <http://www.metraflex.com>

Distributed by: