

MODEL MCF

MODEL MCW

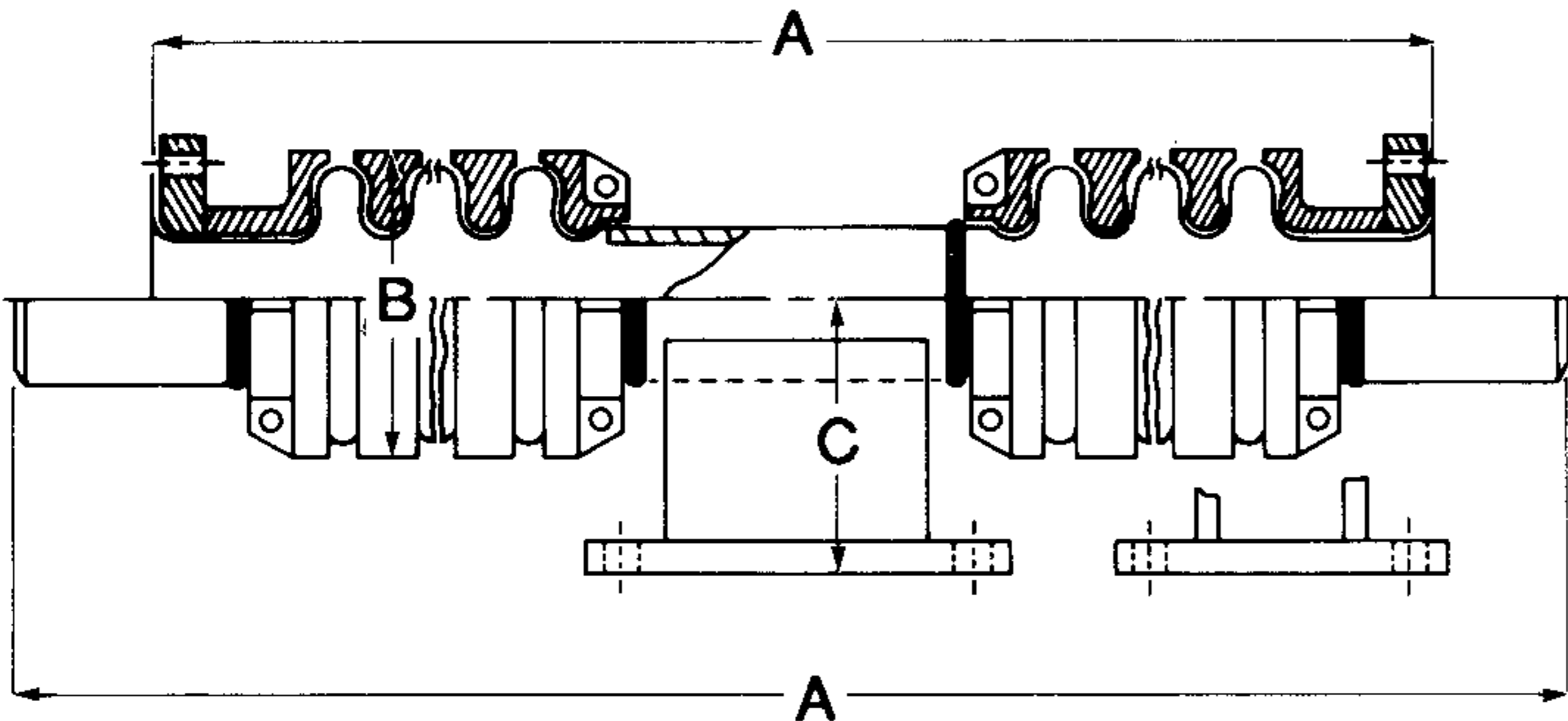

MODEL MCDEA (F) or (W)

**STYLE MC
RING CONTROLLED
EXPANSION JOINT**

DESIGN SPECIFICATIONS:

MAXIMUM WORKING PRESSURE: 300 psi
 WORKING TEMPERATURE: 500°F
 TEST PRESSURE: 450 psi

ALL JOINTS RATED FOR FULL VACUUM.

SIZES 2" - 36" AVAILABLE

MEETS MIL SPEC: MIL-E-17813C

STANDARD MATERIALS OF CONSTRUCTION		
ITEM	NAMES	MATERIAL
1	BELLOWS	T 304 S.S.
2	CONTROL RINGS	CAST IRON
3	FLANGE	CARBON STEEL
4	WELD END	A 53 / A 106

* Optional Materials Available . . .
 Please contact factory.

QTY.	PIPE SIZE	MODEL	# OF CORR.	END FITTING	DIMENSIONS			MOVE- MENT	OPTIONS			NOTES
					A	B	C		TIE RODS	COVER	LINER	

CUSTOMER _____
 PROJECT _____
 ENGINEER _____
 ARCHITECT _____
 PRO OR P.O. NO. _____

the Metraflex company
 CHICAGO ILLINOIS

DESCRIPTION: **MODEL MC**
RING-CONTROLLED EXPANSION JOINT

DRAWN BY : DATE: DRAWING NO:
 TPH 6-14-91 MC-91