

STYLE 711 FRP WIDE ARCH EXPANSION JOINT FOR FIBERGLASS AND PLASTIC PIPE

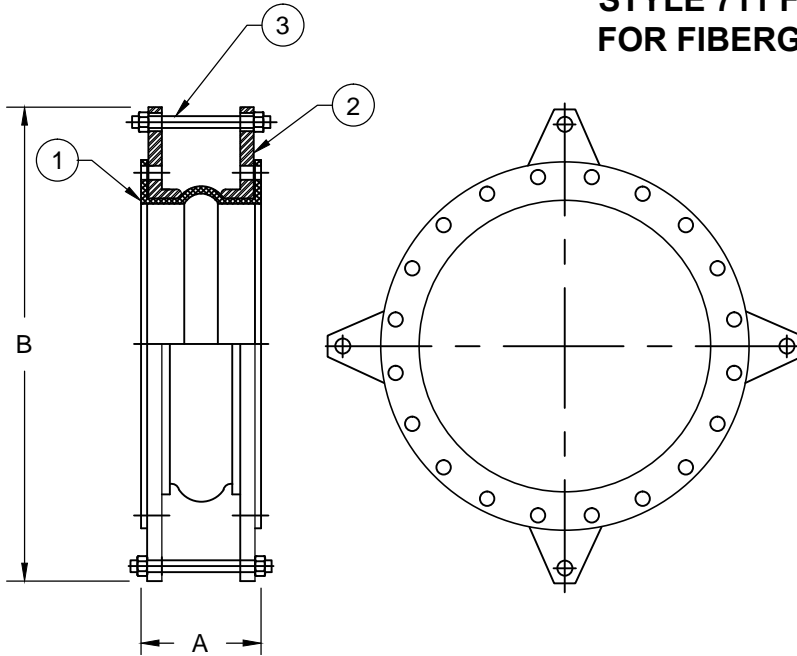

NOTE:
THIS FLEXIBLE JOINT SHOULD BE INSTALLED THE LENGTH SHOWN ON DRAWING. PIPING AND EQUIPMENT CONNECTED BY THIS FLEXIBLE JOINT SHOULD BE ANCHORED AND GUIDED. NOT INTENDED FOR TORSION.

ITEM	NAME	MATERIAL
1	BODY	EPDM
2	RETAINING RING	DUCTILE IRON
3	CONTROL ROD GALVANIZED	C/S

MAXIMUM WORKING TEMPERATURE: 230°

PIPE SIZE	NO. OF CONTROL RODS
2" - 5"	3
6" - 10"	4
12" - 24"	6

QTY.	SIZE (NPS)	A F/F (IN.)	B (IN.)	PRESSURE (PSIG)	VACUUM (IN. HG.)	MOVEMENT CAPABILITY AND FORCES @ 0 PSI *						EFFECTIVE AREA (SQ IN.)	WEIGHT (LB)	
						COMPRESSION		ELONGATION		LATERAL				ANGULAR
						MAX DEFL (IN.)	SPRING RATE (LB/IN.)	MAX DEFL (IN.)	SPRING RATE (LB/IN.)	MAX DEFL (IN.)	SPRING RATE (LB/IN.)			MAX DEFL (DEG.)
	2"	6	8-1/2"	150	10	1-3/4	126	3/4	160	3/4	213	**	14	7
	2-1/2"	6	9-3/8"	150	10	1-3/4	160	3/4	200	3/4	227		17	9
	3"	6	10"	150	10	1-3/4	189	3/4	240	3/4	253		21	10
	4"	6	11-1/8"	150	10	1-3/4	257	3/4	333	3/4	280		36	11
	5"	6	13"	150	10	1-3/4	314	3/4	413	3/4	333		50	14
	6"	6	14"	150	10	1-3/4	383	3/4	493	1	370		66	18
	8"	6	16-1/2"	150	10	1-3/4	423	3/4	547	1	450		101	25
	10"	8	19"	150	10	1-3/4	531	3/4	693	1	480		145	36
	12"	8	22"	150	10	1-3/4	554	3/4	733	1	570		199	48
	14"	8	28"	150	10	2	595	7/8	766	1-1/8	667		260	60
	16"	8	32"	150	10	2	635	7/8	823	1-1/8	773		329	68
	18"	8	33"	150	10	2	715	7/8	926	1-1/8	853		403	77
	20"	8	36"	150	10	2	795	7/8	1029	1-1/8	951		482	77
	24"	10	40"	150	10	2	1070	7/8	1417	1-1/8	1022		695	120

***CALCULATING ANCHOR/THRUST LOADS:**

MULTIPLY THE GREATER OF THE MAXIMUM SYSTEM TEST PRESSURE OR OPERATING PRESSURE TIMES THE EFFECTIVE AREA TO OBTAIN THE FORCE THAT WILL BE EXERTED BY THE PRESSURIZED EXPANSION JOINT ON THE ADJACENT PIPING. ANCHORS MUST BE STRONGER THAN THIS FORCE IF THE JOINT IS TO COMPRESS AND COMPENSATE FOR THE PIPE'S THERMAL EXPANSION. PIPE GUIDES WILL BE NECESSARY TO DIRECT MOVEMENT OF THE PIPE'S EXPANSION.

****DUE TO UNEVEN LOADING OF TIE RODS FACTORY MUST BE CONSULTED.**

CUSTOMER: _____
PROJECT: _____
ENGINEER: _____

REV.	24" F/F UPDATED DATE 04/12/2012	
		2323 W. HUBBARD ST. CHICAGO, IL 60612 TEL: 312-738-3800 FAX: 312-738-0415 WWW.METRAFLEX.COM
DESCRIPTION: STYLE 711 FRP WIDE ARCH EXPANSION JOINT		
DRAWN BY:	MIR	DATE: 04/12/2012
APPROVED:	MIR	DATE: 04/12/2012
SCALE:	DRAWING NUMBER: 711 FRP	
NONE		