

MIGHTYSPHERE™ WITH 150# FLANGES

QTY.	PIPE SIZE (IN)	F/F (IN)	MOVEMENT CAPABILITY AND FORCES									
			AXIAL				DEFLECTION					
			COMP (IN)	APPROX. FORCE (LBS)	ELONG. (IN)	APPROX. FORCE (LBS)	LATERAL (IN)	APPROX. FORCE (FLBS)	ANGULAR (DEGREES)	WEIGHT (LBS)	NO HOLES	BOLT HOLE SIZE
	2	6"	1/2	55	3/16	73	3/8	55	15	8	4	3/4
	2-1/2	6"	1/2	102	3/16	68	3/8	97	15	13	4	3/4
	3	6"	1/2	136	3/16	115	3/8	108	15	14	4	3/4
	4	6"	5/8	145	3/16	242	3/8	275	15	18	8	3/4
	5	6"	5/8	172	3/16	196	3/8	308	15	23	8	7/8
	6	6"	5/8	293	3/16	563	3/8	484	15	28	8	7/8
	8	6"	5/8	372	3/16	587	3/8	688	15	40	8	7/8
	10	8"	3/4	398	1/4	455	1/2	781	15	68	12	1
	12	8"	3/4	390	1/4	356	1/2	842	15	94	12	1

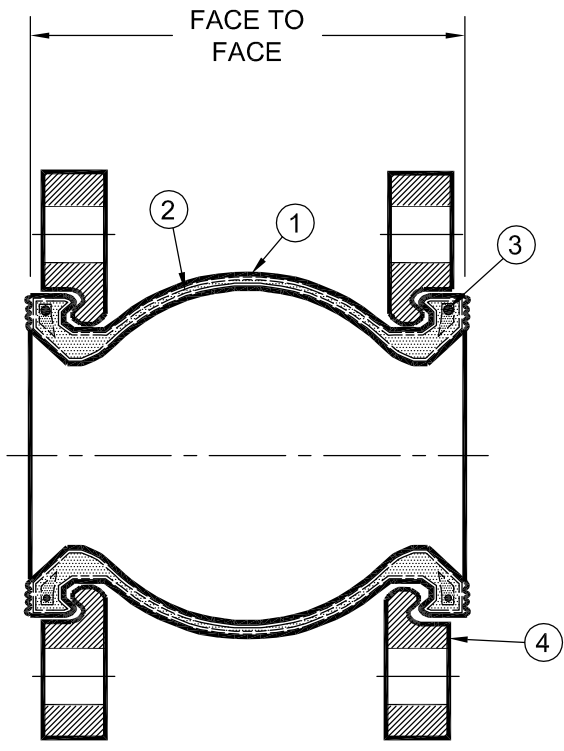

MAXIMUM OPERATING CONDITIONS		
TEMP °F	MAXIMUM PRESSURE PSI	VACUUM (IN. HG.)
	12" & SMALLER	
170	250	16
190	245	16
210	235	16
230	225	16
250	215	16

LIST OF MATERIALS		
ITEM	PART NAME	MATERIAL
1	BODY	PEROXIDE CURED EPDM**
2	REINFORCEMENT	KEVLAR®
3	ANCHOR WIRE	STEEL
4	DRILLED FLANGE	PLATE STEEL

**EPDM IS THE STANDARD ELASTOMER FOR THE INTERIOR AND EXTERIOR COVERING. CONTACT FACTORY (www.metroflex.com) FOR OTHER ELASTOMERS. NOT FOR STEAM APPLICATIONS.

THE FLEXIBLE JOINT SHOULD BE INSTALLED THE LENGTH SHOWN ON DRAWING. PIPING AND EQUIPMENT CONNECTED TO THIS FLEXIBLE JOINT MUST BE ANCHORED AND GUIDED. IF NOT, CONTROL UNITS MUST BE USED TO PREVENT MOVEMENT PAST DESIGN LIMITS. NOT INTENDED FOR TORSION.



TO BE FURNISHED WITH CONTROL UNITS

YES NO

CUSTOMER _____

PROJECT _____

ENGINEER _____

PRO OR P.O. NO. _____

Metraflex
for pipes in motion

2323 W. HUBBARD ST.
CHICAGO, IL 60612
TEL:312-738-3800
FAX:312-738-0415
WWW.METRAFLEX.COM

DESCRIPTION: **MIGHTYSPHERE™**

DRAWN BY: AD DATE: 01/19/2011

APPROVED BY: MR DATE: 11/16/2011

SCALE: NONE DRAWING NUMBER: MSRDK REV. 1