

METRASPHERE STYLE "MSC" 150# FLANGED

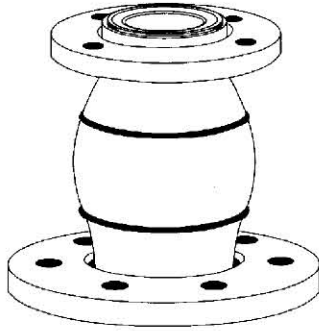

This flexible joint should be installed the length shown on drawing. Piping and equipment connected by this flexible joint must be anchored and guided. If not, control units must be used to prevent movement past design limits. Not intended for torsion.

ITEM	NAME	MATERIAL
1	BODY	EPDM & NYLON
2	WIRE	STEEL
3	FLANGE	PLATE STEEL

MAXIMUM WORKING TEMPERATURE 230° F

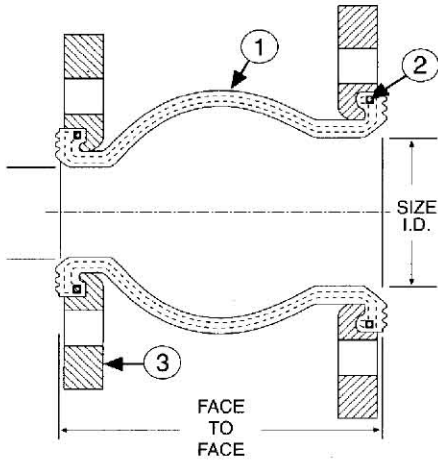

OPTIONAL MATERIALS AVAILABLE
Go to www.metroflex.com/

TO BE FURNISHED WITH CONTROL UNITS YES NO

*Maximum Operating Conditions

Temperature (°F)	Maximum Pressure PSI
	12" & Smaller
170°	225
180°	200
190°	175
200°	150
210°	125
220°	100
230°	75

*EPDM is the standard elastomer for the interior and exterior covering. Contact factory for other elastomers. **Not for steam applications.**

MOVEMENT CAPABILITY AND FORCES

Qty	Size I.D. (in)	F/F (in)	Pressure* P.S.I.G.	Vacuum (in. Hg)	AXIAL				DEFLECTION			Weight (Lbs)
					Comp. (in)	Approx. Force (Lbs)	Elong. (in)	Approx. Force (Lbs)	Lateral (in)	Approx. Force (Lbs)	Angular (Degrees)	
	3 x 2	8	225	16	1/2	136	3/8	115	1/2	108	15	15
	3 x 2-1/2	8	225	16	1/2	136	3/8	115	1/2	108	15	16
	4 x 2	8	225	16	5/8	145	3/8	242	1/2	275	15	18
	4 x 3	8	225	16	5/8	145	3/8	242	1/2	275	15	19
	6 x 4	8	225	16	5/8	293	3/8	563	1/2	484	15	28
	8 x 4	8	225	16	5/8	372	1/2	587	1/2	688	15	40
	8 x 6	8	225	16	5/8	372	1/2	587	1/2	688	15	46
	10 x 8	8	225	16	3/4	398	1/2	455	3/4	781	15	69

CUSTOMER _____

PROJECT _____

ENGINEER _____

ARCHITECT _____

PRO. OR P.O. NO. _____

Metroflex.
for pipes in motion

DESCRIPTION:

METRASPHERE STYLE "MSC"
CONCENTRIC REDUCING SPHERICAL EXPANSION JOINT

DRAWING BY:
JRR

DATE:
9/4/08

DRAWING NO.
MSC-REV2