

MODEL LPD LOW PRESSURE DROP 125# FLANGED STRAINER

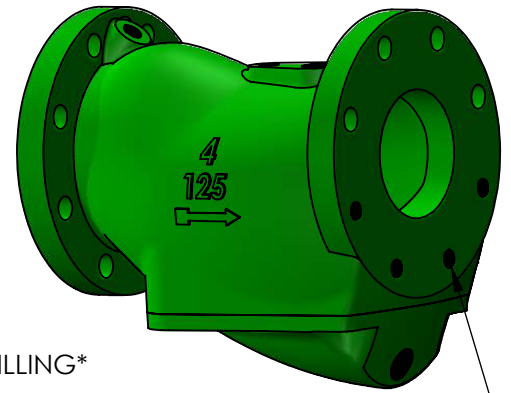
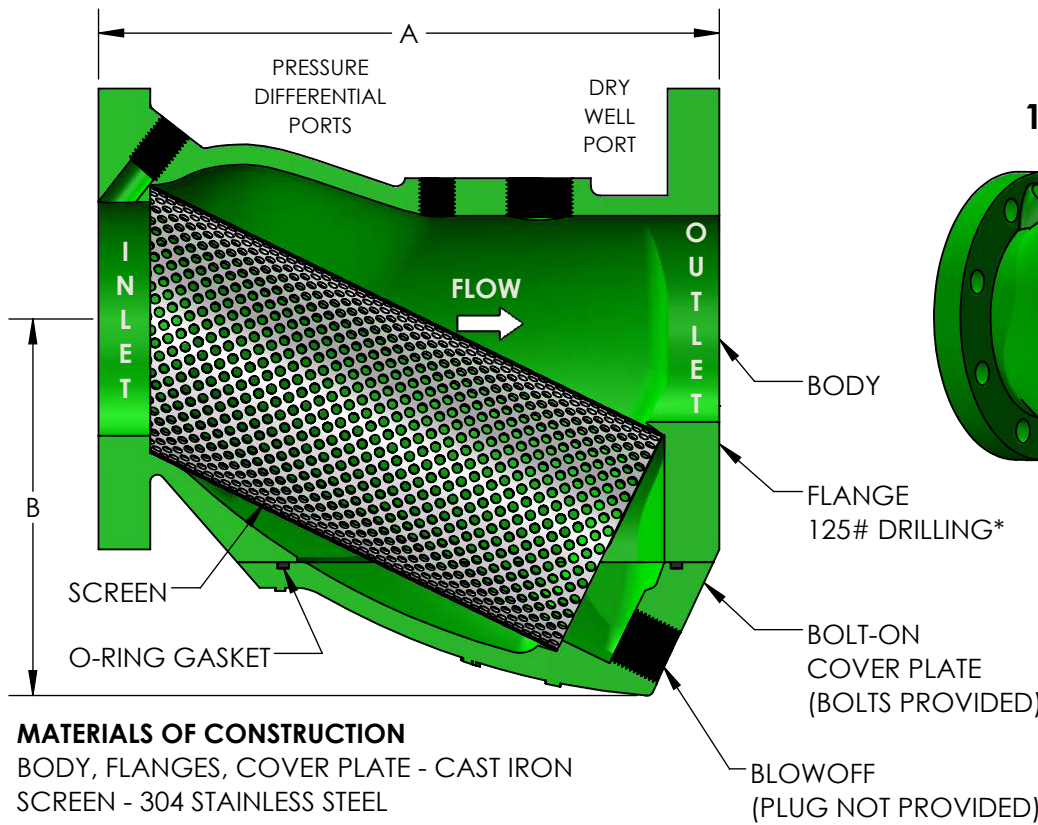

*TAPPED BOLT HOLES
HALF OF THE BOLT HOLES ON
THE OUTLET END ARE TAPPED.
SEE TAP SIZE BELOW FOR SIZING.

MATERIALS OF CONSTRUCTION

BODY, FLANGES, COVER PLATE - CAST IRON
SCREEN - 304 STAINLESS STEEL
O-RING GASKET - VITON

OPERATING TEMPERATURE/PRESSURE

WATER, OIL, GAS.....175 PSI @ 150°F
STEAM**.....125 PSI @ 350°F

** IF FOR STEAM, STEAM GASKET MUST BE SPECIFIED

STANDARD SCREENS

SERVICE	SIZE	PERF
LIQUID	2" - 3"	.045"
	4" - 12"	.125"
STEAM**	2" - 6"	.045"
	8" - 12"	.062"

QTY	PART NUMBER	PIPE SIZE		A	B	Cv# (GPM)	SCREEN AREA (in ²)	PORT SIZE (NPT)		BLOWOFF SIZE (NPT)	TAP SIZE (UNC)	TAP DEPTH	WEIGHT (LBS)
		INCH	MM					1 & 2	3				
	LPD0200	2"	50	7-7/8"	4-5/8"	120	52.0	1/4"	1/2"	3/4"	5/8"-11	0.5"	20
	LPD0250	2-1/2"	65	10"	5-1/4"	160	84.6	1/4"	1/2"	3/4"	5/8"-11	0.5"	30
	LPD0300	3"	80	10-1/8"	6-1/4"	236	99.0	1/4"	1/2"	1"	5/8"-11	0.875"	50
	LPD0400	4"	100	12-1/8"	7-3/8"	460	147.3	3/8"	1"	1"	5/8"-11	0.875"	75
	LPD0500	5"	125	15-5/8"	8-3/8"	600	226.5	3/8"	1"	1-1/2"	3/4"-10	0.875"	115
	LPD0600	6"	150	18-1/2"	10-5/8"	952	317.6	3/8"	1"	1-1/2"	3/4"-10	0.875"	154
	LPD0800	8"	200	22-1/2"	13"	1580	515.0	3/8"	1"	1-1/2"	3/4"-10	1"	273
	LPD1000	10"	250	27"	16-5/8"	2424	745.2	3/8"	1"	2"	7/8"-9	1.125"	464
	LPD1200	12"	300	29-7/8"	19-3/4"	3200	1035.1	3/8"	1"	2"	7/8"-9	1.125"	565
	LPD1400	14"	350	33-1/4"	22-1/4"	N/A	1276.0	3/8"	1"	2"	1"-8	1.25"	900
	LPD1600	16"	400	38-3/4"	25-5/8"	N/A	1750.0	3/8"	1"	2"	1"-8	1.25"	1300

#Cv IS THE FLOW RATE IN GALLONS OF 60°F WATER THAT WILL PASS THROUGH THE STRAINER IN 1 MINUTE AT A 1 PSI PRESSURE DROP.

NSF 372 - LEAD FREE

The wetted surface of this product contacted by consumable water contains less than one quarter of one percent (0.25%) of lead by weight. Material complies with state codes and standards, where applicable, requiring reduced lead content.

CUSTOMER: _____

PROJECT: _____

ENGINEER: _____

8	14" AND 16" ADDED	6/10/2020
7	2-1/2" BLOWOFF ADJUSTED	4/12/2018
REV.	6 BLOWOFF ADJUSTED	DATE 12/6/2016

Metraflex
for pipes in motion

2323 W. HUBBARD ST.
CHICAGO, IL 60612
TEL: 312-738-3800
FAX: 312-738-0415
WWW.METRAFLEX.COM

MODEL LPD LOW PRESSURE DROP 125# FLANGED STRAINER

DRAWN BY: DKISH DATE: 11/23/2015

APPROVED: JR DATE: 11/23/2015

SCALE: N/A DRAWING NUMBER: LPD-8