

MODEL LPD LOW PRESSURE DROP 125# FLANGED STRAINER

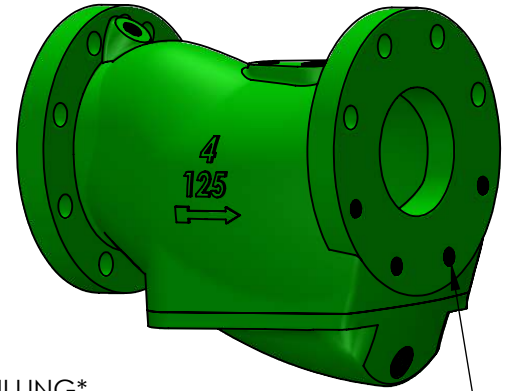
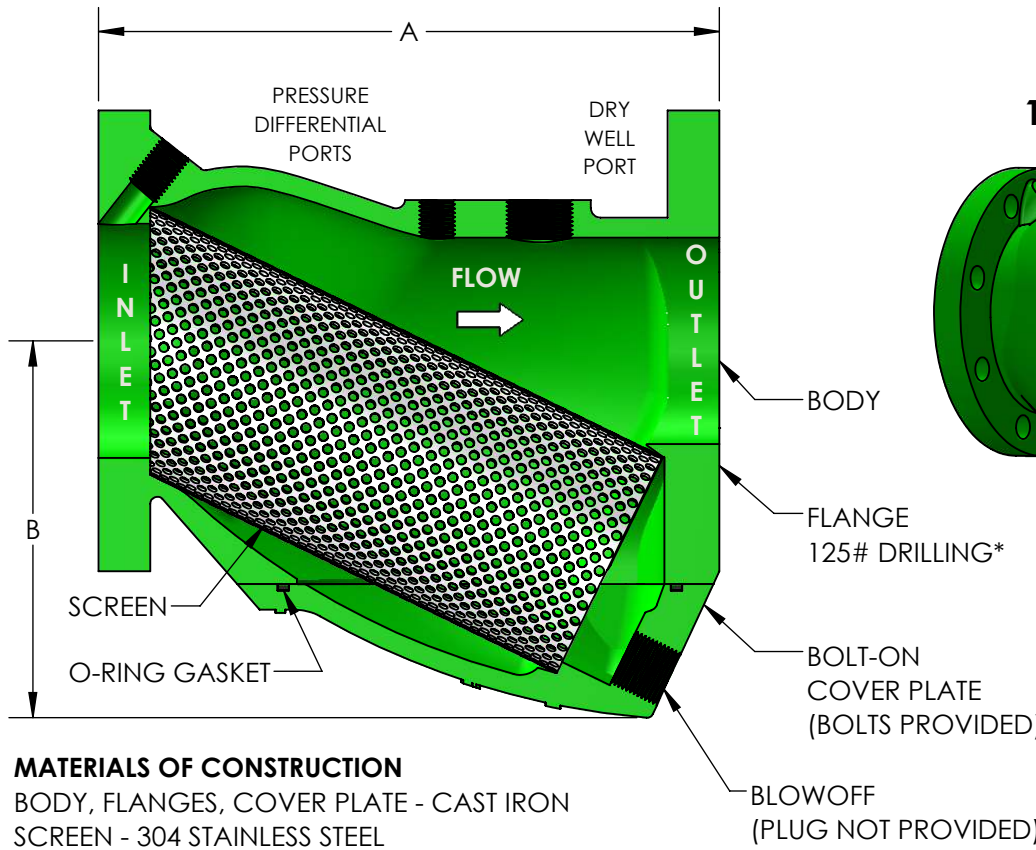

*TAPPED BOLT HOLES
HALF OF THE BOLT HOLES ON
THE OUTLET END ARE TAPPED.
SEE TAP SIZE BELOW FOR SIZING.

MATERIALS OF CONSTRUCTION

BODY, FLANGES, COVER PLATE - CAST IRON
SCREEN - 304 STAINLESS STEEL
O-RING GASKET - EPDM

OPERATING TEMPERATURE/PRESSURE

WATER, OIL, GAS.....175 PSI @ 150°F
STEAM**.....125 PSI @ 350°F

**IF FOR STEAM, STEAM GASKET MUST BE SPECIFIED.

STANDARD SCREENS

SERVICE	SIZE	PERF
LIQUID	2" - 3"	.045"
	4" - 16"	.125"
STEAM**	2" - 6"	.045"
	8" - 16"	.062"

QTY	PART NUMBER	PIPE SIZE		A	B	SCREEN AREA (in ²)	PORT SIZE (NPT)		BLOWOFF SIZE (NPT)	TAP SIZE (UNC)	WEIGHT (LBS)
		INCH	MM				1 & 2	3			
	LPD0200	2"	50	7-7/8"	4-5/8"	52.0	1/4"	1/2"	3/4"	5/8"-11	20
	LPD0250	2-1/2"	65	10"	5-1/4"	84.6	1/4"	1/2"	3/4"	5/8"-11	30
	LPD0300	3"	80	10-1/8"	6-1/4"	99.0	1/4"	1/2"	1"	5/8"-11	50
	LPD0400	4"	100	12-1/8"	7-3/8"	147.3	1/4"	1"	1"	5/8"-11	75
	LPD0600	6"	150	18-1/2"	10-5/8"	317.6	1/4"	1"	1-1/2"	3/4"-10	154
	LPD0800	8"	200	22-1/2"	13"	515.0	1/4"	1"	1-1/2"	3/4"-10	273
	LPD1000	10"	250	27"	16-5/8"	745.2	1/4"	1"	2"	7/8"-9	464
	LPD1200	12"	300	29-7/8"	19-3/4"	1035.1	1/4"	1"	2"	7/8"-9	565
	LPD1400	14"	350	33-1/4"	23"	1276	1/4"	1"	2"	1"-8	900
	LPD1600	16"	400	38-3/4"	28"	1750	1/4"	1"	2"	1"-8	1300

NSF 372 - LEAD FREE

The wetted surface of this product contacted by consumable water contains less than one quarter of one percent (0.25%) of lead by weight. Material complies with state codes and standards, where applicable, requiring reduced lead content.

CUSTOMER: _____

PROJECT: _____

ENGINEER: _____

2	2" SIZE ADDED	12/04/2020
REV. 1	SCREEN AREA ADDED	DATE 12/21/2015
		2323 W. HUBBARD ST. CHICAGO, IL 60612 TEL: 312-738-3800 FAX: 312-738-0415 WWW.METRAFLEX.COM

MODEL LPD	
LOW PRESSURE DROP 125# FLANGED STRAINER	
DRAWN BY: RDAHYA	DATE: 12/04/2020
APPROVED:	DATE:
SCALE: N/A	DRAWING NUMBER: LPD-3