

**MODEL LPD 10" - 16"  
LOW PRESSURE DROP  
125# FLANGED STRAINER**

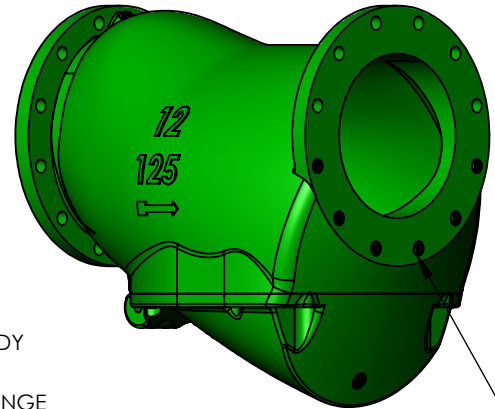
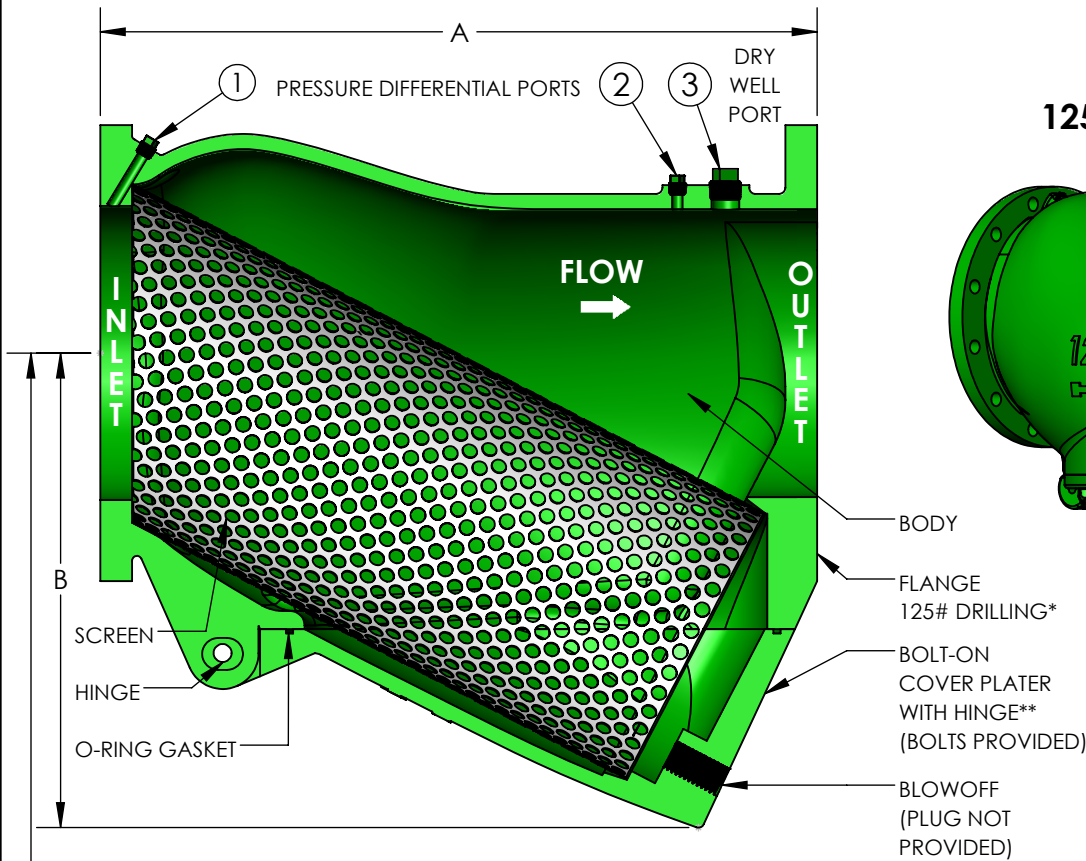

\*TAPPED BOLT HOLES  
HALF OF THE BOLT HOLES ON THE OUTLET END ARE TAPPED. SEE TAP SIZE BELOW FOR SIZING. STUDS PROVIDED FOR TAPPED HOLES.

C (CLEARANCE TO REMOVE STRAINER FROM BELOW)  
\*IF THERE IS NOT ENOUGH CLEARANCE BELOW STRAINER, PRODUCT CAN BE ROTATED 90° AXIALLY TO PROVIDE CLEARANCE OR FOR STEAM APPLICATION TO MINIMIZE CONDENSATE COLLECTION

**STANDARD SCREENS**

SERVICE	SIZE	PERF
LIQUID	10" - 16"	.125"
STEAM	10" - 16"	.062"

**MATERIALS OF CONSTRUCTION**

BODY, FLANGES, COVER PLATE - CAST IRON  
SCREEN - 304 STAINLESS STEEL  
O-RING GASKET - VITON

**OPERATING TEMPERATURE/PRESSURE**

WATER, OIL, GAS..... 175 PSI @ 150°F  
STEAM..... 125 PSI @ 350°F

QTY	PART NUMBER	PIPE SIZE		A	B	C	#Cv (GPM)	SCREEN AREA (in <sup>2</sup> )	PORT SIZE (NPT)		BLOWOFF SIZE (NPT)	TAP SIZE (UNC)	TAP DEPTH	WEIGHT (LBS)
		INCH	MM						1 & 2	3				
	LPD1000	10"	250	27"	16-5/8"	37-7/8"	2424	745.2	3/8"	1"	2"	7/8"-9	1.125"	464
	LPD1200	12"	300	29-7/8"	19-3/4"	43-5/8"	3200	1035.1	3/8"	1"	2"	7/8"-9	1.125"	565
	LPD1400	14"	350	33-1/4"	22-1/4"	49-1/2"	N/A	1276.0	3/8"	1"	2"	1"-8	1.25"	900
	LPD1600	16"	400	38-3/4"	25-5/8"	58-1/4"	N/A	1750.0	3/8"	1"	2"	1"-8	1.25"	1300

# Cv IS THE FLOW RATE IN GALLONS OF 60°F WATER THAT WILL PASS THROUGH THE STRAINER IN 1 MINUTE AT A 1 PSI PRESSURE DROP.

**NSF 372 - LEAD FREE**

The wetted surface of this product contacted by consumable water contains less than one quarter of one percent (0.25%) of lead by weight. Material complies with state codes and standards, where applicable, requiring reduced lead content.

CUSTOMER: \_\_\_\_\_

PROJECT: \_\_\_\_\_

ENGINEER: \_\_\_\_\_

REV.	DATE
2323 W. HUBBARD ST. CHICAGO, IL 60612 TEL: 312-738-3800 FAX: 312-738-0415 WWW.METRAFLEX.COM	
<b>MODEL LPD 10"-16"</b> LOW PRESSURE DROP 125# FLANGED STRAINER	
DRAWN BY: BDIAZ	DATE: 7/7/2022
APPROVED:	DATE:
SCALE: NTS	DRAWING NUMBER: LPD-10-16