

METRAFLEX METRAGATOR
150 PSI, 4" AXIAL COMPRESSION, FLANGED
EXTERNALLY PRESSURIZED EXPANSION JOINT

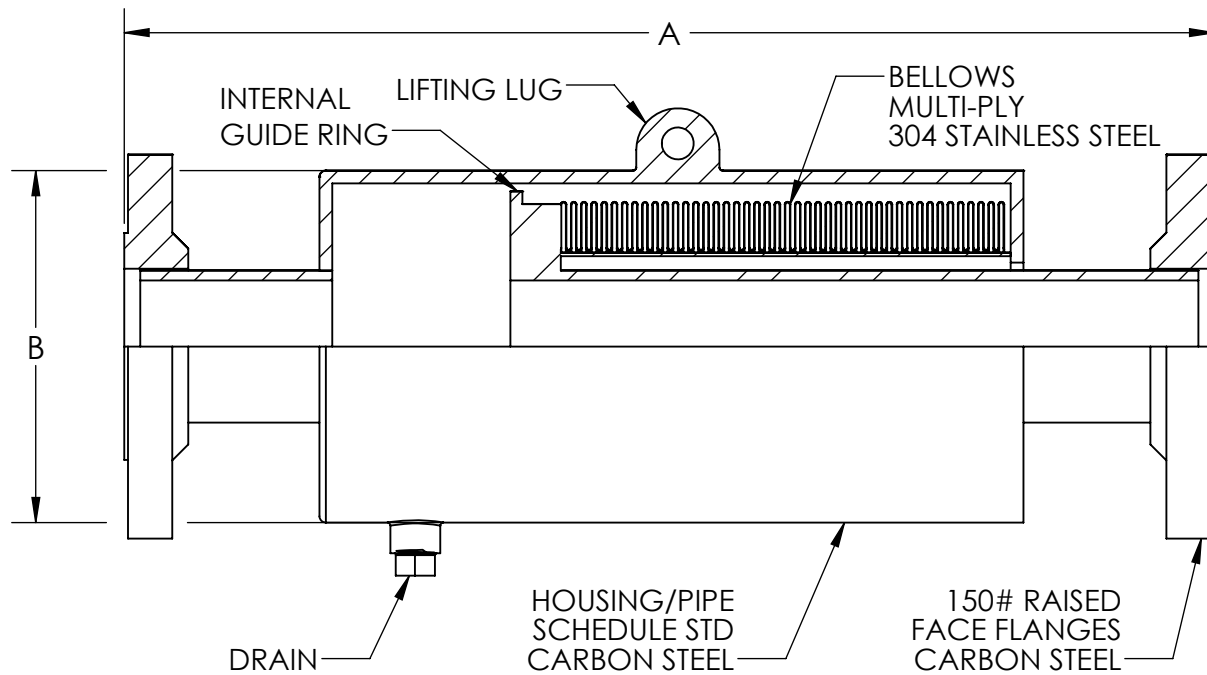

THE EXPANSION JOINT IS DESIGNED FOR AXIAL MOVEMENT ONLY. PIPE MUST BE PROPERLY GUIDED AND ANCHORED PER THE RECOMMENDATIONS OF THE EXPANSION JOINT MANUFACTURERS ASSOCIATION.

QTY	PART NUMBER	PIPE SIZE		A (in)	B (in)	EFF. AREA (in ²)	SPRING RATE (lb/in)	NOTES
		NPS	MM					
	GAT04SF0200	2	50	25	5.5	13.2	183.0	
	GAT04SF0250	2.5	65	25	5.5	13.2	183.0	
	GAT04SF0300	3	80	24	6.5	20.8	343.0	
	GAT04SF0400	4	100	25	8.5	36.0	200.0	
	GAT04SF0500	5	130	25	10.75	46.4	235.0	
	GAT04SF0600	6	150	25.5	12.75	58.9	269.0	
	GAT04SF0800	8	200	28.25	14	88.8	332.0	
	GAT04SF1000	10	250	27	16	124.6	400.0	
	GAT04SF1200	12	300	27	18	166.6	463.0	

DESIGN DATA

TEMPERATURE: 500°F (370°C)
 PRESSURE: 150 PSI (1034 KPa)
 TEST PRESSURE: 225 PSI (1551 KPa)
 AXIAL MOVEMENT: 4" COMPRESSION (100 mm)

MILITARY SPECS:
 CONFORMS TO MIL-E-17813H AND ASTM-F-2934

CUSTOMER: _____

PROJECT: _____

ENGINEER: _____

NOTE: ANCHOR LOAD =
 (MAX PSI X EFFECTIVE AREA) +
 (SPRING RATE X MOVEMENT)

ADDITIONAL NOTE:
 DRAIN NPT SIZE (SIZES 2" - 6") : 1/2"
 DRAIN NPT SIZE (SIZES 8" - 12") : 3/4"

2	ADDED DRAIN SIZE	03/18/2024
REV. 1	RAISED FACE FLANGES	DATE 6/24/2020

Metraflex
for pipes in motion

2323 W. HUBBARD ST.
 CHICAGO, IL 60612
 TEL: 312-738-3800
 FAX: 312-738-0415
 WWW.METRAFLEX.COM

**METRAFLEX METRAGATOR, 150 PSI,
 4" AXIAL COMPRESSION, FLANGED**

DRAWN BY: DKISH	DATE: 6/1/2015
APPROVED: ZB	DATE: 6/2/2015
SCALE: N/A	DRAWING NUMBER: GAT04SF-2

METRAFLEX METRAGATOR
150 PSI, 6" AXIAL COMPRESSION, FLANGED
EXTERNALLY PRESSURIZED EXPANSION JOINT

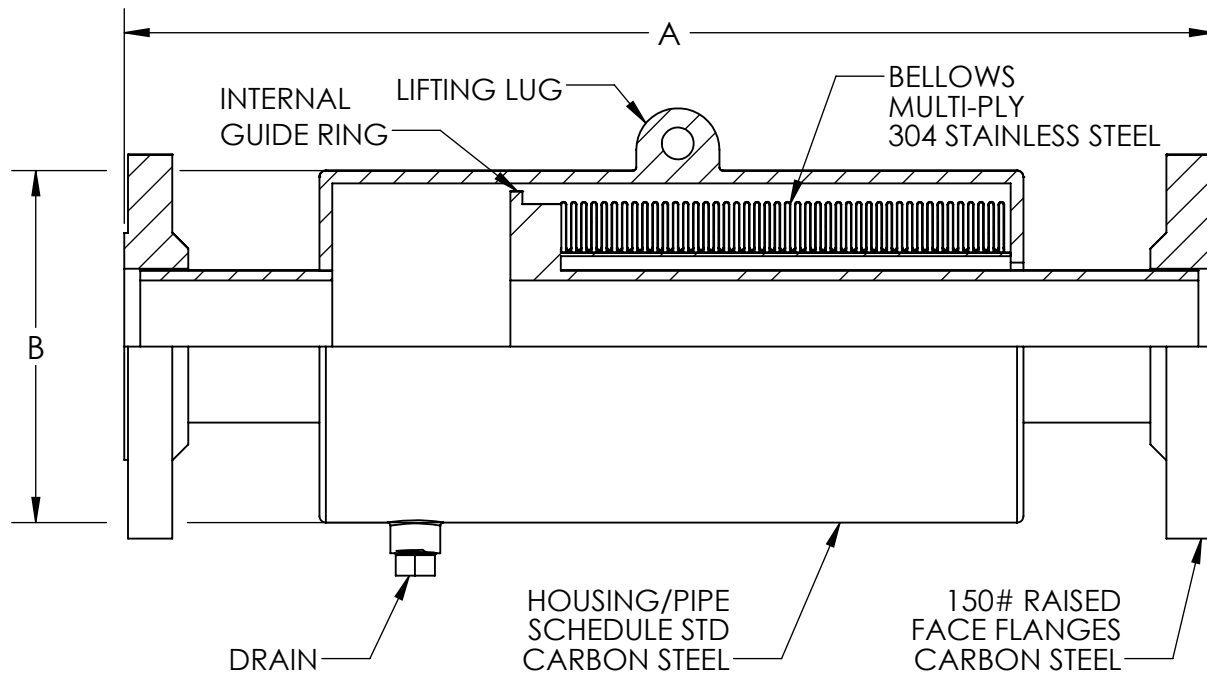

THE EXPANSION JOINT IS DESIGNED FOR AXIAL MOVEMENT ONLY. PIPE MUST BE PROPERLY GUIDED AND ANCHORED PER THE RECOMMENDATIONS OF THE EXPANSION JOINT MANUFACTURERS ASSOCIATION.

QTY	PART NUMBER	PIPE SIZE		A (in)	B (in)	EFF. AREA (in ²)	SPRING RATE (lb/in)	NOTES
		NPS	MM					
	GAT06SF0200	2	50	31.5	5.5	13.2	115.0	
	GAT06SF0250	2.5	65	32	5.5	13.2	115.0	
	GAT06SF0300	3	80	30	6.5	20.8	235.0	
	GAT06SF0400	4	100	31.25	8.5	36.0	143.0	
	GAT06SF0500	5	130	31.5	10.75	46.4	166.0	
	GAT06SF0600	6	150	32.25	12.75	58.9	189.0	
	GAT06SF0800	8	200	34.75	14	88.8	235.0	
	GAT06SF1000	10	250	34	16	124.6	280.0	
	GAT06SF1200	12	300	33.25	18	166.6	326.0	

DESIGN DATA

MAXIMUM OPERATING TEMPERATURE: 500°F (260°C)
 PRESSURE: 150 PSI (1034 KPa)
 TEST PRESSURE: 225 PSI (1551 KPa)
 AXIAL MOVEMENT: 6" COMPRESSION (150 mm)

MILITARY SPECS:

CONFORMS TO MIL-E-17813H AND ASTM-F-2934

NOTE: ANCHOR LOAD =
 (MAX PSI X EFFECTIVE AREA) +
 (SPRING RATE X MOVEMENT)

ADDITIONAL NOTE:

DRAIN NPT SIZE (SIZES 2" - 6") : 1/2"
 DRAIN NPT SIZE (SIZES 8" - 12") : 3/4"

2	ADDED DRAIN SIZE	03/18/2024
REV. 1	RAISED FACE FLANGES	DATE 6/24/2020

Metraflex
for pipes in motion

2323 W. HUBBARD ST.
 CHICAGO, IL 60612
 TEL: 312-738-3800
 FAX: 312-738-0415
 WWW.METRAFLEX.COM

**METRAFLEX METRAGATOR, 150 PSI,
 6" AXIAL COMPRESSION, FLANGED**

DRAWN BY: DKISH	DATE: 6/1/2015
APPROVED: ZB	DATE: 6/2/2015
SCALE: N/A	DRAWING NUMBER: GAT06SF-2

CUSTOMER: _____

PROJECT: _____

ENGINEER: _____

METRAFLEX METRAGATOR
150 PSI, 8" AXIAL COMPRESSION, FLANGED
EXTERNALLY PRESSURIZED EXPANSION JOINT

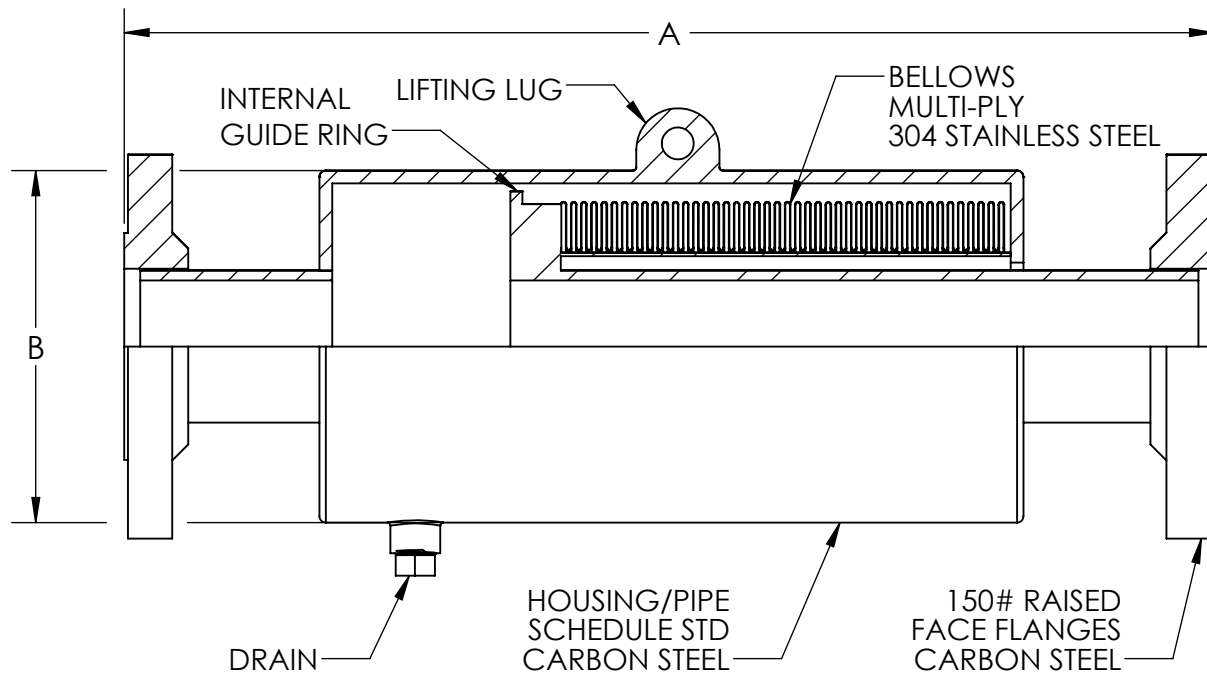

THE EXPANSION JOINT IS DESIGNED FOR AXIAL MOVEMENT ONLY. PIPE MUST BE PROPERLY GUIDED AND ANCHORED PER THE RECOMMENDATIONS OF THE EXPANSION JOINT MANUFACTURERS ASSOCIATION.

QTY	PART NUMBER	PIPE SIZE		A (in)	B (in)	EFF. AREA (in ²)	SPRING RATE (lb/in)	NOTES
		NPS	MM					
	GAT08SF0200	2	50	38.5	5.5	13.2	92.0	
	GAT08SF0250	2.5	65	38.5	5.5	13.2	92.0	
	GAT08SF0300	3	80	38.5	6.5	20.8	172.0	
	GAT08SF0400	4	100	37.75	8.5	36.0	103.0	
	GAT08SF0500	5	130	38.25	10.75	46.4	120.0	
	GAT08SF0600	6	150	38.5	12.75	58.9	138.0	
	GAT08SF0800	8	200	42	14	88.8	166.0	
	GAT08SF1000	10	250	40.25	16	124.6	200.0	
	GAT08SF1200	12	300	39.75	18	166.6	235.0	

DESIGN DATA

TEMPERATURE: 500°F (370°C)
 PRESSURE: 150 PSI (1034 KPa)
 TEST PRESSURE: 225 PSI (1551 KPa)
 AXIAL MOVEMENT: 8" COMPRESSION (200 mm)

MILITARY SPECS:
 CONFORMS TO MIL-E-17813H AND ASTM-F-2934

NOTE: ANCHOR LOAD =
 (MAX PSI X EFFECTIVE AREA) +
 (SPRING RATE X MOVEMENT)

ADDITIONAL NOTE:
 DRAIN NPT SIZE (SIZES 2" - 6") : 1/2"
 DRAIN NPT SIZE (SIZES 8" - 12") : 3/4"

CUSTOMER: _____

PROJECT: _____

ENGINEER: _____

2	ADDED DRAIN SIZE	03/18/2024
REV. 1	RAISED FACE FLANGES	DATE 6/24/2020

Metraflex
for pipes in motion

2323 W. HUBBARD ST.
 CHICAGO, IL 60612
 TEL: 312-738-3800
 FAX: 312-738-0415
 WWW.METRAFLEX.COM

**METRAFLEX METRAGATOR, 150 PSI,
 8" AXIAL COMPRESSION, FLANGED**

DRAWN BY: DKISH	DATE: 6/1/2015
APPROVED: ZB	DATE: 6/2/2015
SCALE: N/A	DRAWING NUMBER: GAT08SF-2