

**METRAFLEX METRAGATOR**  
**300 PSI, 4" AXIAL COMPRESSION, FLANGED**  
**EXTERNALLY PRESSURIZED EXPANSION JOINT**

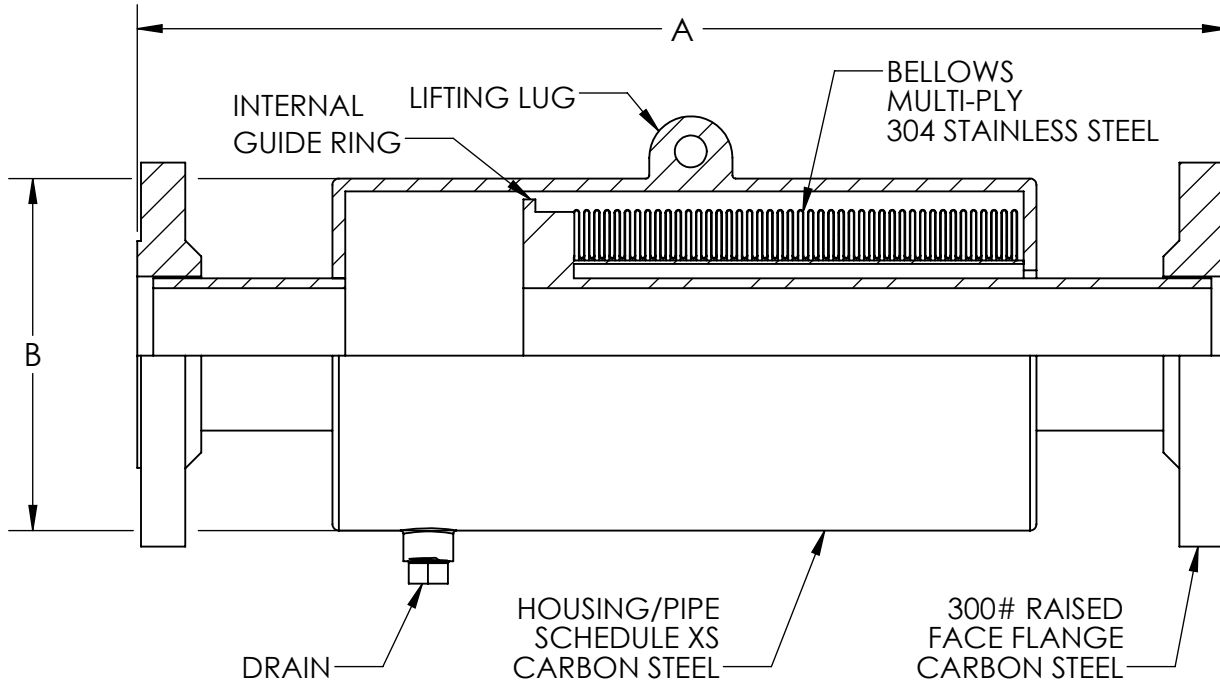

THE EXPANSION JOINT IS DESIGNED FOR AXIAL MOVEMENT ONLY. PIPE MUST BE PROPERLY GUIDED AND ANCHORED PER THE RECOMMENDATIONS OF THE EXPANSION JOINT MANUFACTURERS ASSOCIATION.

QTY	PART NUMBER	PIPE SIZE		A (in)	B (in)	EFF. AREA (in <sup>2</sup> )	SPRING RATE (lb/in)	NOTES
		NPS	MM					
	GAT3004SF0200	2	50	29	6.625	14.3	639.1	
	GAT3004SF0250	2.5	65	29	6.625	14.3	639.1	
	GAT3004SF0300	3	80	28	8.625	22.9	823.5	
	GAT3004SF0400	4	100	28.75	10.75	36.4	1223.2	
	GAT3004SF0500	5	130	28.25	10.75	46.7	1615.1	
	GAT3004SF0600	6	150	28.25	12.75	59.4	1803.0	
	GAT3004SF0800	8	200	29.5	14	93.0	2591.7	
	GAT3004SF1000	10	250	30.25	16	129.7	2833.8	
	GAT3004SF1200	12	300	31.75	18	172.5	2853.6	

**DESIGN DATA**

TEMPERATURE: 500°F (260°C)  
 PRESSURE: 300 PSI (2068 KPa)  
 TEST PRESSURE: 450 PSI (3102 KPa)  
 AXIAL MOVEMENT: 4" COMPRESSION (100 mm)

NOTE: ANCHOR LOAD =  
 (MAX PSI X EFFECTIVE AREA) +  
 (SPRING RATE X MOVEMENT)

**MILITARY SPECS:**

CONFORMS TO MIL-E-17813H AND ASTM-F-2934

CUSTOMER: \_\_\_\_\_

PROJECT: \_\_\_\_\_

ENGINEER: \_\_\_\_\_

REV. 1	TEMPERATURE ADJUST	DATE 4/29/2021
		2323 W. HUBBARD ST. CHICAGO, IL 60612 TEL: 312-738-3800 FAX: 312-738-0415 WWW.METRAFLEX.COM
METRAFLEX METRAGATOR, 300 PSI, 4" AXIAL COMPRESSION, FLANGED		
DRAWN BY: DKISH		DATE: 6/1/2015
APPROVED: ZB		DATE: 6/2/2015
SCALE: N/A	DRAWING NUMBER: GAT3004SF-1	

**METRAFLEX METRAGATOR**  
**300 PSI, 8" AXIAL COMPRESSION, FLANGED**  
**EXTERNALLY PRESSURIZED EXPANSION JOINT**

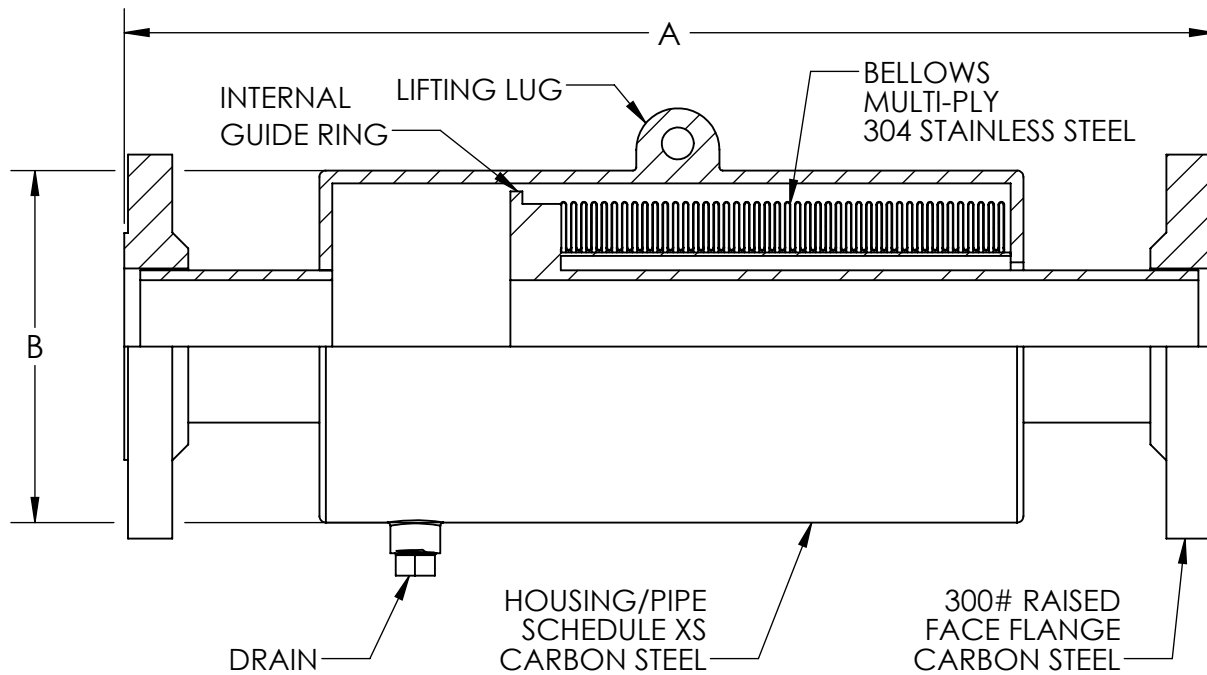

THE EXPANSION JOINT IS DESIGNED FOR AXIAL MOVEMENT ONLY. PIPE MUST BE PROPERLY GUIDED AND ANCHORED PER THE RECOMMENDATIONS OF THE EXPANSION JOINT MANUFACTURERS ASSOCIATION.

QTY	PART NUMBER	PIPE SIZE		A (in)	B (in)	EFF. AREA (in <sup>2</sup> )	SPRING RATE (lb/in)	NOTES
		NPS	MM					
	GAT3008SF0200	2	50	45.5	6.625	14.3	339.5	
	GAT3008SF0250	2.5	65	45.75	6.625	14.3	339.5	
	GAT3008SF0300	3	80	43.75	8.625	22.9	441.2	
	GAT3008SF0400	4	100	44.25	10.75	36.4	662.6	
	GAT3008SF0500	5	130	41.25	10.75	46.7	987.0	
	GAT3008SF0600	6	150	41.25	12.75	59.4	1101.9	
	GAT3008SF0800	8	200	43	14	93.0	1583.8	
	GAT3008SF1000	10	250	47.75	16	129.7	1416.9	
	GAT3008SF1200	12	300	49.25	18	172.5	1539.6	

**DESIGN DATA**

TEMPERATURE: 500°F (260°C)  
 PRESSURE: 300 PSI (2068 KPa)  
 TEST PRESSURE: 450 PSI (3102 KPa)  
 AXIAL MOVEMENT: 8" COMPRESSION (200 mm)

NOTE: ANCHOR LOAD =  
 (MAX PSI X EFFECTIVE AREA) +  
 (SPRING RATE X MOVEMENT)

**MILITARY SPECS:**

CONFORMS TO MIL-E-17813H AND ASTM-F-2934

REV.	1	TEMPERATURE ADJUST	DATE	4/29/2021
		2323 W. HUBBARD ST. CHICAGO, IL 60612 TEL: 312-738-3800 FAX: 312-738-0415 WWW.METRAFLEX.COM		
		METRAFLEX METRAGATOR, 300 PSI, 8" AXIAL COMPRESSION, FLANGED		
DRAWN BY: DKISH		DATE: 6/1/2015		
APPROVED: ZB		DATE: 6/2/2015		
SCALE: N/A		DRAWING NUMBER: GAT3008SF-1		

CUSTOMER: \_\_\_\_\_

PROJECT: \_\_\_\_\_

ENGINEER: \_\_\_\_\_