

METRAFLEX METRAGATOR
300 PSI, 4" AXIAL COMPRESSION, WELD ENDS
EXTERNALLY PRESSURIZED EXPANSION JOINT

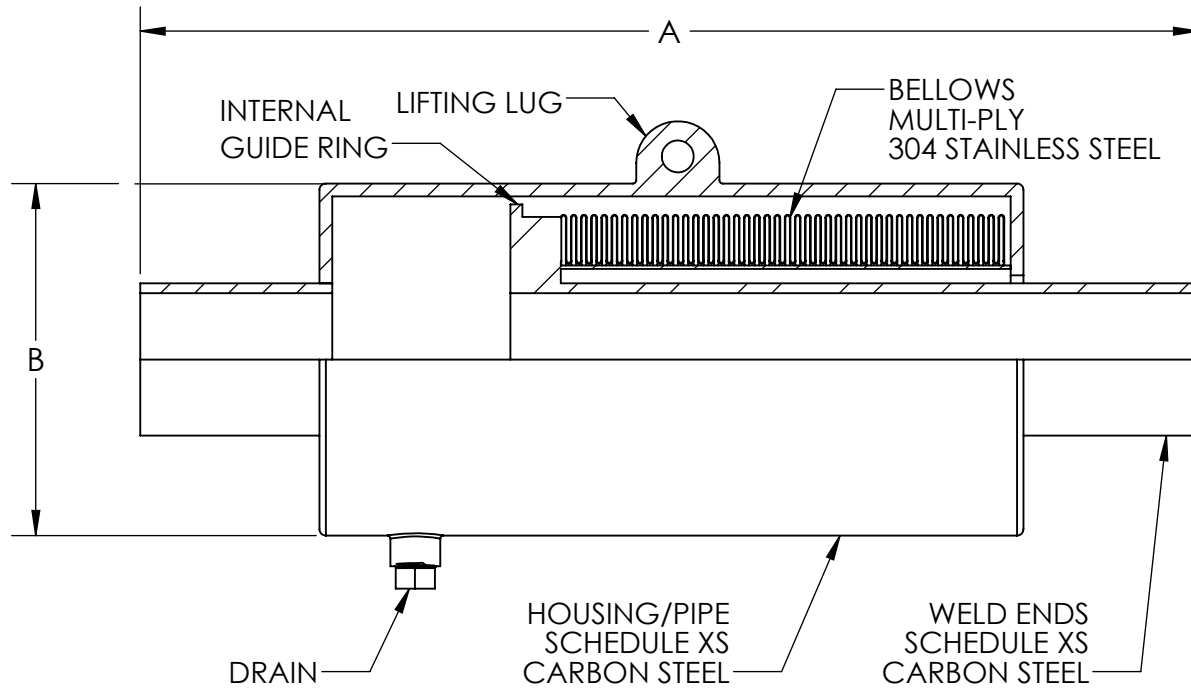

THE EXPANSION JOINT IS DESIGNED FOR AXIAL MOVEMENT ONLY. PIPE MUST BE PROPERLY GUIDED AND ANCHORED PER THE RECOMMENDATIONS OF THE EXPANSION JOINT MANUFACTURERS ASSOCIATION.

QTY	PART NUMBER	PIPE SIZE		A (in)	B (in)	EFF. AREA (in ²)	SPRING RATE (lb/in)	NOTES
		NPS	MM					
	GAT3004SW0200	2	50	28.5	6.625	14.3	639.1	
	GAT3004SW0250	2.5	65	28.5	6.625	14.3	639.1	
	GAT3004SW0300	3	80	27.5	8.625	22.9	823.5	
	GAT3004SW0400	4	100	28.25	10.75	36.4	1223.2	
	GAT3004SW0500	5	130	27.75	10.75	46.7	1615.1	
	GAT3004SW0600	6	150	27.75	12.75	59.4	1803.0	
	GAT3004SW0800	8	200	29	14	93.0	2591.7	
	GAT3004SW1000	10	250	29.75	16	129.7	2833.8	
	GAT3004SW1200	12	300	31.25	18	172.5	2853.6	

DESIGN DATA

MAXIMUM OPERATING TEMPERATURE: 500°F (260°C)
 PRESSURE: 300 PSI (2068 KPa)
 TEST PRESSURE: 450 PSI (3102 KPa)
 AXIAL MOVEMENT: 4" COMPRESSION (100 mm)

MILITARY SPECS:

CONFORMS TO MIL-E-17813H AND ASTM-F-2934

NOTE: ANCHOR LOAD =

(MAX PSI X EFFECTIVE AREA) +
 (SPRING RATE X MOVEMENT)

ADDITIONAL NOTE:

DRAIN NPT SIZE (SIZES 2" - 6") : 1/2"
 DRAIN NPT SIZE (SIZES 8" - 12") : 3/4"

2	ADDED DRAIN SIZE	03/18/2024
REV. 1	TEMPERATURE ADJUST	DATE 4/29/2021

Metraflex
for pipes in motion

2323 W. HUBBARD ST.
 CHICAGO, IL 60612
 TEL: 312-738-3800
 FAX: 312-738-0415
 WWW.METRAFLEX.COM

METRAFLEX METRAGATOR, 300 PSI, 4" AXIAL COMPRESSION, WELD ENDS	
DRAWN BY: DKISH	DATE: 6/1/2015
APPROVED: ZB	DATE: 6/2/2015
SCALE: N/A	DRAWING NUMBER: GAT3004SW-1

CUSTOMER: _____

PROJECT: _____

ENGINEER: _____

METRAFLEX METRAGATOR
300 PSI, 8" AXIAL COMPRESSION, WELD ENDS
EXTERNALLY PRESSURIZED EXPANSION JOINT

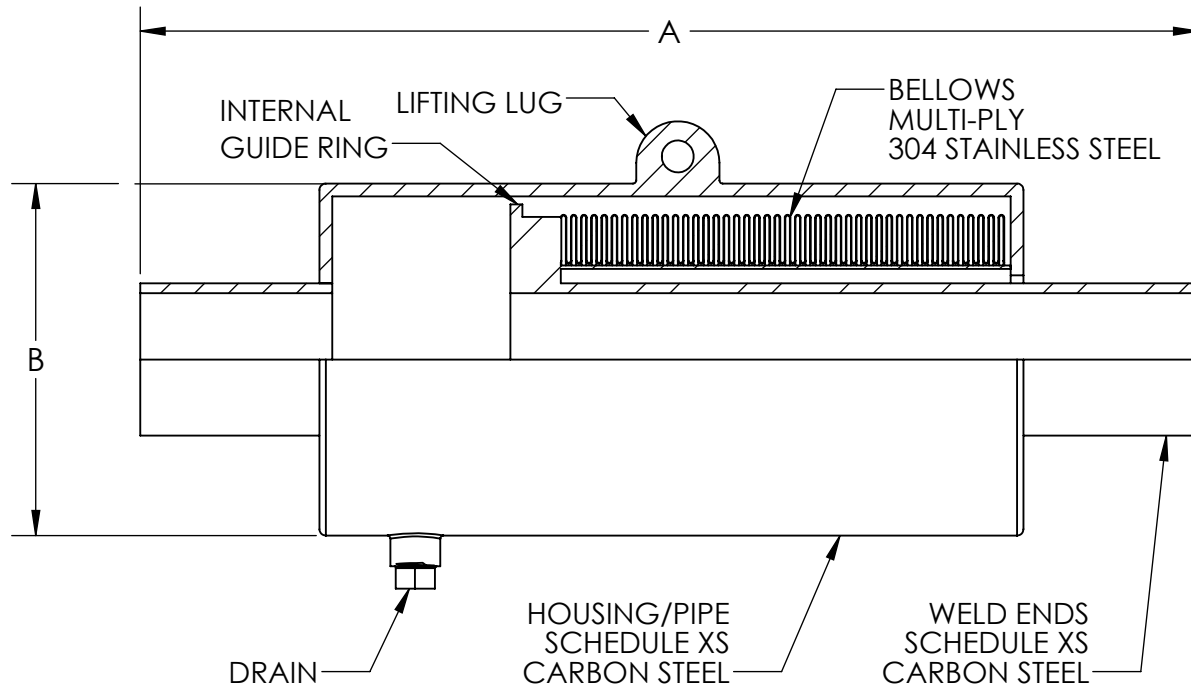

THE EXPANSION JOINT IS DESIGNED FOR AXIAL MOVEMENT ONLY. PIPE MUST BE PROPERLY GUIDED AND ANCHORED PER THE RECOMMENDATIONS OF THE EXPANSION JOINT MANUFACTURERS ASSOCIATION.

QTY	PART NUMBER	PIPE SIZE		A (in)	B (in)	EFF. AREA (in ²)	SPRING RATE (lb/in)	NOTES
		NPS	MM					
	GAT3008SW0200	2	50	45	6.625	14.3	339.5	
	GAT3008SW0250	2.5	65	45.25	6.625	14.3	339.5	
	GAT3008SW0300	3	80	43.25	8.625	22.9	441.2	
	GAT3008SW0400	4	100	43.75	10.75	36.4	662.6	
	GAT3008SW0500	5	130	40.75	10.75	46.7	987.0	
	GAT3008SW0600	6	150	40.75	12.75	59.4	1101.9	
	GAT3008SW0800	8	200	42.5	14	93.0	1583.8	
	GAT3008SW1000	10	250	47.25	16	129.7	1416.9	
	GAT3008SW1200	12	300	48.75	18	172.5	1539.6	

DESIGN DATA

MAXIMUM OPERATING TEMPERATURE: 500°F (260°C)
 PRESSURE: 300 PSI (2068 KPa)
 TEST PRESSURE: 450 PSI (3102 KPa)
 AXIAL MOVEMENT: 8" COMPRESSION (200 mm)

MILITARY SPECS:

CONFORMS TO MIL-E-17813H AND ASTM-F-2934

NOTE: ANCHOR LOAD =
 (MAX PSI X EFFECTIVE AREA) +
 (SPRING RATE X MOVEMENT)

ADDITIONAL NOTE:

DRAIN NPT SIZE (SIZES 2" - 6") : 1/2"
 DRAIN NPT SIZE (SIZES 8" - 12") : 3/4"

CUSTOMER: _____

PROJECT: _____

ENGINEER: _____

2	ADDED DRAIN SIZE	03/18/2024
REV. 1	TEMPERATURE ADJUST	DATE 4/29/2021

Metraflex
for pipes in motion

2323 W. HUBBARD ST.
 CHICAGO, IL 60612
 TEL: 312-738-3800
 FAX: 312-738-0415
 WWW.METRAFLEX.COM

**METRAFLEX METRAGATOR, 300 PSI,
 8" AXIAL COMPRESSION, WELD ENDS**

DRAWN BY: DKISH	DATE: 6/1/2015
APPROVED: ZB	DATE: 6/2/2015
SCALE: N/A	DRAWING NUMBER: GAT3008SW-1