

**MODEL MSRDBB, STYLE "R" METRASPHERE  
BUTYL EXPANSION JOINT, DRILLED BOLT HOLES**

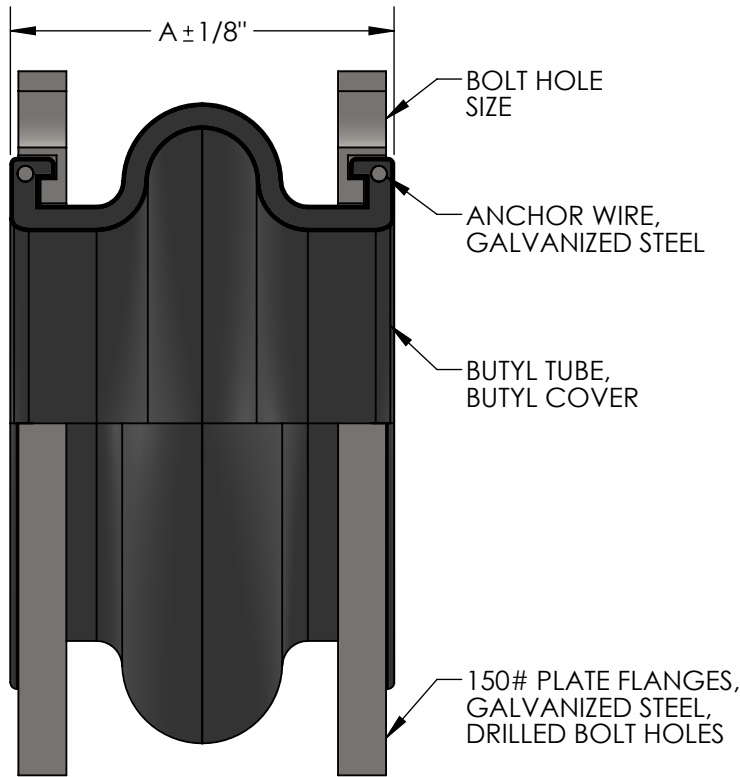

**MAXIMUM OPERATING CONDITIONS**

TEMPERATURE	PRESSURE (PSI)	
	1" - 12"	14" AND UP
170°	225	125
180°	200	115
190°	175	105
200°	150	95
210°	125	40
220°	100	35
230°	75	25

MAXIMUM WORKING TEMPERATURE 230°F

**NOTES:**

WWW.METRAFLEX.COM FOR INSTALLATION INSTRUCTIONS.  
JOINT MUST BE INSTALLED AT ITS NEUTRAL LENGTH.  
BOLTS MUST BE PROPERLY TORQUED.  
NOT SUITABLE FOR STEAM OR VACUUM APPLICATIONS.  
IF CONNECTING PIPE IS NOT ANCHORED AND GUIDED,  
CONTROL UNITS MUST BE USED.

TO BE FURNISHED WITH CONTROL UNITS:

YES  NO

QTY	PART NUMBER	PIPE SIZE		A	AXIAL COMP.	FORCE (LBS)	AXIAL EXT.	FORCE (LBS)	LATERAL OFFSET	FORCE (LBS)	ANGULAR	WEIGHT (LBS)	BOLT HOLE SIZE
		INCH	MM										
	MSRDBB0100	1"	25	6"	1/2"	N/A	3/8"	N/A	1/2"	N/A	15°	5	5/8"
	MSRDBB0125	1-1/4"	32	6"	1/2"	N/A	3/8"	N/A	1/2"	N/A	15°	6	5/8"
	MSRDBB0150	1-1/2"	38	6"	1/2"	N/A	3/8"	N/A	1/2"	N/A	15°	7	5/8"
	MSRDBB0200	2"	50	6"	1/2"	55	3/8"	73	1/2"	55	15°	8	3/4"
	MSRDBB0250	2-1/2"	65	6"	1/2"	102	3/8"	68	1/2"	97	15°	13	3/4"
	MSRDBB0300	3"	80	6"	1/2"	136	3/8"	115	1/2"	108	15°	14	3/4"
	MSRDBB0400	4"	100	6"	5/8"	145	3/8"	242	1/2"	275	15°	18	3/4"
	MSRDBB0500	5"	125	6"	5/8"	172	3/8"	196	1/2"	308	15°	23	7/8"
	MSRDBB0600	6"	150	6"	5/8"	293	3/8"	563	1/2"	484	15°	28	7/8"
	MSRDBB0800	8"	200	6"	5/8"	372	1/2"	587	1/2"	688	15°	40	7/8"
	MSRDBB1000	10"	250	8"	3/4"	398	1/2"	455	3/4"	781	15°	68	1"
	MSRDBB1200	12"	300	8"	3/4"	390	1/2"	356	3/4"	842	15°	94	1"
	MSRDBB1400	14"	350	8"	3/4"	N/A	1/2"	N/A	3/4"	N/A	15°	105	1-1/8"
	MSRDBB1600	16"	400	8"	3/4"	N/A	1/2"	N/A	3/4"	N/A	15°	120	1-1/8"
	MSRDBB1800	18"	450	8"	3/4"	N/A	1/2"	N/A	3/4"	N/A	15°	125	1-1/4"
	MSRDBB2000	20"	500	8"	3/4"	N/A	1/2"	N/A	3/4"	N/A	15°	145	1-1/4"
	MSRDBB2400	24"	600	10"	3/4"	N/A	1/2"	N/A	3/4"	N/A	15°	265	1-3/8"

**NSF 372 - LEAD FREE**

The wetted surface of this product contacted by consumable water contains less than one quarter of one percent (0.25%) of lead by weight. Material complies with state codes and standards, where applicable, requiring reduced lead content.

CUSTOMER: \_\_\_\_\_

PROJECT: \_\_\_\_\_

ENGINEER: \_\_\_\_\_

REV.	DATE
	
2323 W. HUBBARD ST. CHICAGO, IL 60612 TEL: 312-738-3800 FAX: 312-738-0415 WWW.METRAFLEX.COM	
<b>METRASPHERE MODEL MSRDBB</b> BUTYL EXPANSION JOINT, DRILLED BOLT HOLES	
DRAWN BY: <b>DKISH</b>	DATE: <b>1/19/2017</b>
APPROVED: <b>JC</b>	DATE: <b>1/23/2017</b>
SCALE: <b>N/A</b>	DRAWING NUMBER: <b>MSRDBB-1</b>

**CONTROL UNIT SELECTION CHART / DIMENSIONS  
FOR MODELS MSR, 100HT, 711 ONLY**

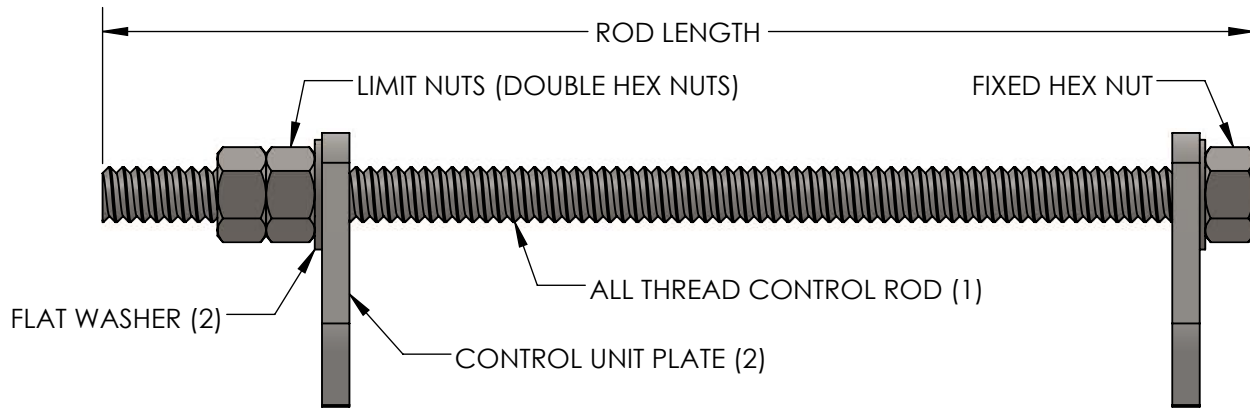

CONSULT FACTORY FOR NUMBER OF CONTROL UNITS REQUIRED

PIPE SIZE	ROD TYPE	ROD THICKNESS	ROD LENGTH	PLATE TYPE	PLATE THICKNESS	PLATE OD
1"	GUSRD058X120	5/8"	12"	GUSPLT01	3/8"	8-3/8"
1-1/4"	GUSRD058X120	5/8"	12"	GUSPLT01	3/8"	8-3/4"
1-1/2"	GUSRD058X120	5/8"	12"	GUSPLT01	3/8"	9-1/8"
2"	GUSRD058X120	5/8"	12"	GUSPLT0204	3/8"	10-1/8"
2-1/2"	GUSRD058X120	5/8"	12"	GUSPLT2503	3/8"	11-1/8"
3"	GUSRD058X120	5/8"	12"	GUSPLT2503	3/8"	11-5/8"
4"	GUSRD058X120	5/8"	12"	GUSPLT0204	3/8"	13-1/8"
5"	GUSRD058X120	5/8"	12"	GUSPLT0506	1/2"	14-1/8"
6"	GUSRD058X120	5/8"	12"	GUSPLT0506	1/2"	15-1/8"
8"	GUSRD100X145	1"	14-1/2"	GUSPLT0800	1/2"	19-1/8"
10"	GUSRD100X170	1"	17"	GUSPLT1012	3/4"	21-5/8"
12"	GUSRD100X170	1"	17"	GUSPLT1012	3/4"	24-5/8"
14"	GUSRD100X170	1"	17"	GUSPLT1400	3/4"	26-5/8"
16"	GUSRD125X185	1-1/4"	18-1/2"	GUSPLT1600	3/4"	30-1/8"
18"	GUSRD125X185	1-1/4"	18-1/2"	GUSPLT1800	3/4"	31-5/8"
20"	GUSRD125X185	1-1/4"	18-1/2"	GUSPLT2000	3/4"	34-1/8"
24"	GUSRD125X215	1-1/4"	21-1/2"	GUSPLT2400	1"	38-5/8"

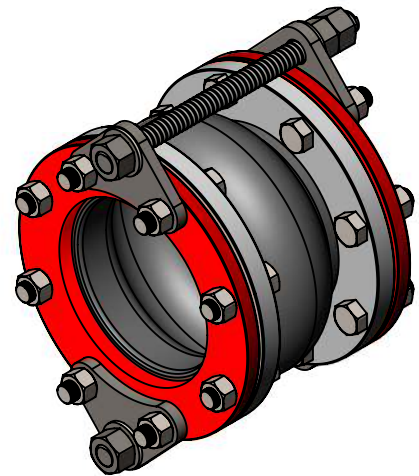
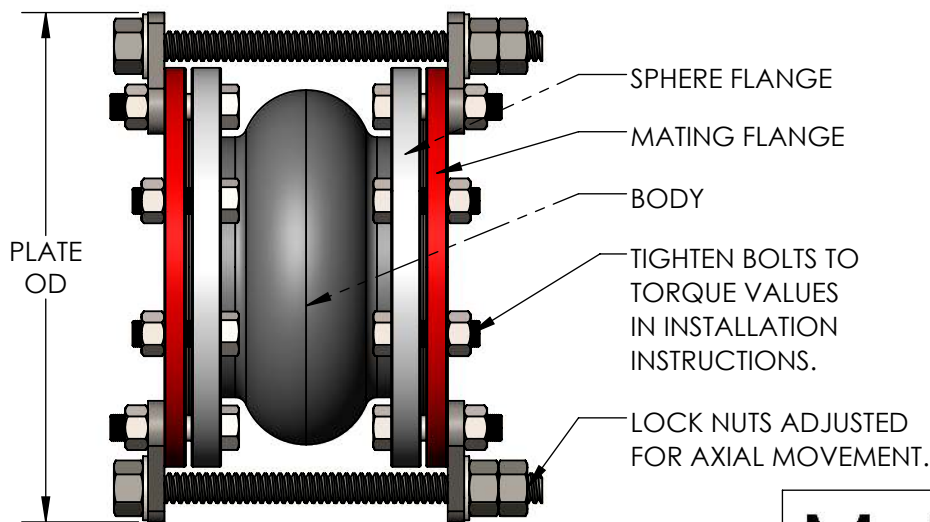

CUSTOMER: \_\_\_\_\_

PROJECT: \_\_\_\_\_

ENGINEER: \_\_\_\_\_

**Metraflex**  
for pipes in motion

2323 W. HUBBARD ST.  
CHICAGO, IL 60612  
TEL: 312-738-3800  
FAX: 312-738-0415  
WWW.METRAFLEX.COM

CONTROL UNITS FOR MSR, 100HT, 711

DRAWN BY: <b>DKISH</b>	DATE: <b>1/5/2017</b>
APPROVED: <b>JC</b>	DATE: <b>1/6/2017</b>
SCALE: N/A	DRAWING NUMBER: CONTROLUNIT-MSR100711