

**MODEL MSODEE, STYLE "O" METRASPHERE
EPDM EXPANSION JOINT, DRILLED BOLT HOLES**

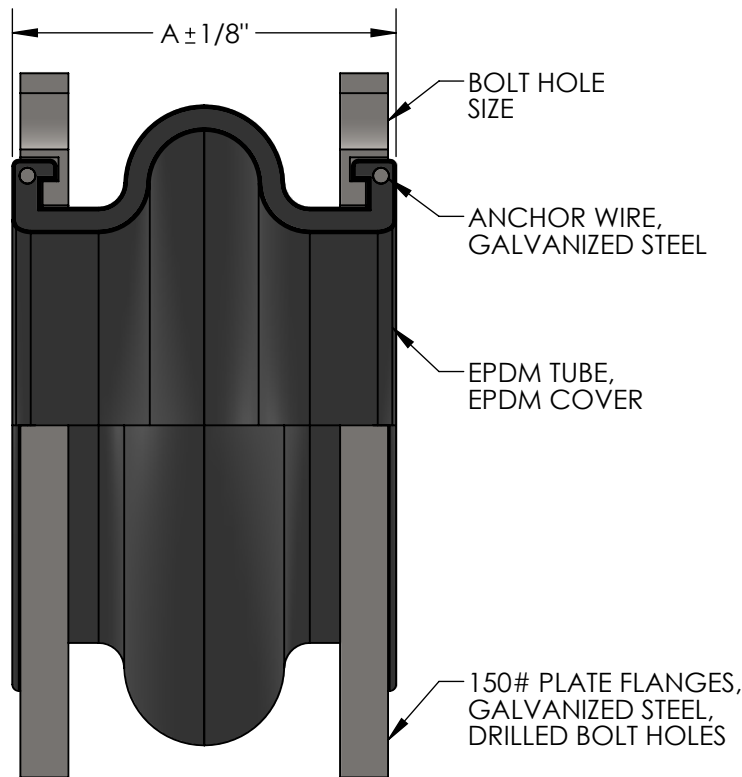

MAXIMUM OPERATING CONDITIONS

TEMPERATURE	PRESSURE (PSI)	
	1" - 12"	14" AND UP
170°	225	125
180°	200	115
190°	175	105
200°	150	95
210°	125	40
220°	100	35
230°	75	25

MAXIMUM WORKING TEMPERATURE 230°F

NOTES:

WWW.METRAFLEX.COM FOR INSTALLATION INSTRUCTIONS.
JOINT MUST BE INSTALLED AT ITS NEUTRAL LENGTH.
BOLTS MUST BE PROPERLY TORQUED.
NOT SUITABLE FOR STEAM OR VACUUM APPLICATIONS.
IF CONNECTING PIPE IS NOT ANCHORED AND GUIDED,
CONTROL UNITS MUST BE USED.

QTY	PART NUMBER	PIPE SIZE		A	AXIAL COMP.	FORCE (LBS)	AXIAL EXT.	FORCE (LBS)	LATERAL OFFSET	FORCE (LBS)	ANGULAR	WEIGHT (LBS)	BOLT HOLE SIZE
		INCH	MM										
	MSODEE0100	1"	25	3-3/4"	1/4"	N/A	3/32"	N/A	1/4"	N/A	15°	5	5/8"
	MSODEE0125	1-1/4"	32	3-3/4"	1/4"	N/A	3/32"	N/A	1/4"	N/A	15°	6	5/8"
	MSODEE0150	1-1/2"	38	3-3/4"	1/4"	N/A	3/32"	N/A	1/4"	N/A	15°	7	5/8"
	MSODEE0200	2"	50	4-1/8"	3/8"	55	1/4"	73	3/8"	55	15°	8	3/4"
	MSODEE0250	2-1/2"	65	4-1/2"	1/2"	102	1/4"	68	3/8"	97	15°	13	3/4"
	MSODEE0300	3"	80	5-1/8"	1/2"	136	1/4"	115	3/8"	108	15°	14	3/4"
	MSODEE0400	4"	100	5-3/8"	3/4"	145	3/8"	242	1/2"	275	15°	18	3/4"
	MSODEE0500	5"	125	6-3/4"	3/4"	172	3/8"	196	1/2"	308	15°	23	7/8"
	MSODEE0600	6"	150	7-1/8"	3/4"	293	3/8"	563	1/2"	484	15°	28	7/8"
	MSODEE0800	8"	200	8-1/8"	1"	372	1/2"	587	7/8"	688	15°	40	7/8"
	MSODEE1000	10"	250	9-3/8"	1"	398	1/2"	455	7/8"	781	15°	68	1"
	MSODEE1200	12"	300	10-1/4"	1"	390	1/2"	356	7/8"	842	15°	94	1"
	MSODEE1400	14"	350	10-1/2"	1"	N/A	5/8"	N/A	7/8"	N/A	15°	105	1-1/8"
	MSODEE1600	16"	400	10-1/2"	1"	N/A	5/8"	N/A	7/8"	N/A	15°	120	1-1/8"
	MSODEE1800	18"	450	10-1/2"	1"	N/A	5/8"	N/A	7/8"	N/A	15°	125	1-1/4"
	MSODEE2000	20"	500	10-1/2"	1"	N/A	5/8"	N/A	7/8"	N/A	15°	145	1-1/4"
	MSODEE2400	24"	600	10-1/2"	1"	N/A	5/8"	N/A	7/8"	N/A	15°	265	1-3/8"

NSF 372 - LEAD FREE

The wetted surface of this product contacted by consumable water contains less than one quarter of one percent (0.25%) of lead by weight. Material complies with state codes and standards, where applicable, requiring reduced lead content.

CUSTOMER: _____

PROJECT: _____

ENGINEER: _____

REV.	DATE
	
2323 W. HUBBARD ST. CHICAGO, IL 60612 TEL: 312-738-3800 FAX: 312-738-0415 WWW.METRAFLEX.COM	
METRASPHERE MODEL MSODEE EPDM EXPANSION JOINT, DRILLED BOLT HOLES	
DRAWN BY: DKISH	DATE: 1/19/2017
APPROVED: JC	DATE: 1/23/2017
SCALE: N/A	DRAWING NUMBER: MSODEE-1

CONTROL UNIT SELECTION CHART / DIMENSIONS FOR MODEL MSO ONLY

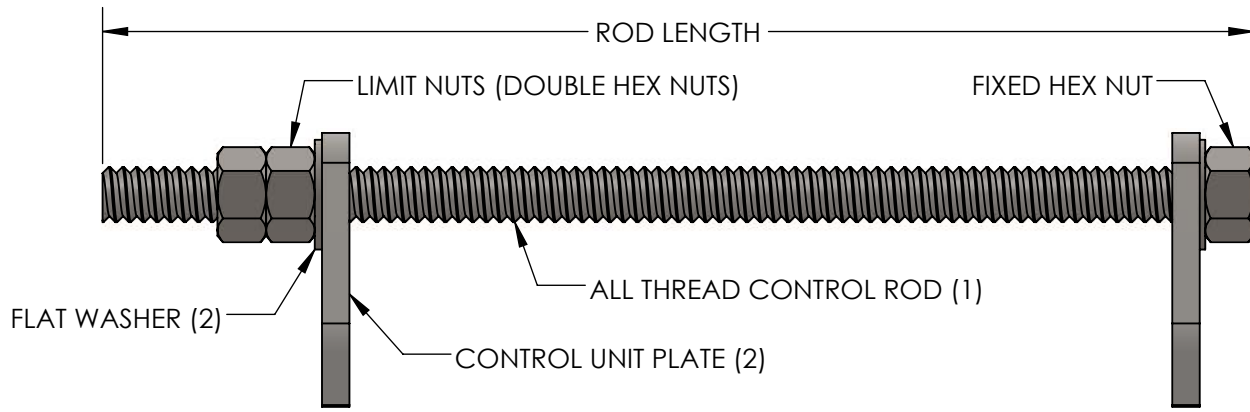

CONSULT FACTORY FOR NUMBER OF CONTROL UNITS REQUIRED

PIPE SIZE	ROD TYPE	ROD THICKNESS	ROD LENGTH	PLATE TYPE	PLATE THICKNESS	PLATE OD
1"	GUSRD058X120	5/8"	12"	GUSPLT01	3/8"	8-3/8"
1-1/4"	GUSRD058X120	5/8"	12"	GUSPLT01	3/8"	8-3/4"
1-1/2"	GUSRD058X120	5/8"	12"	GUSPLT01	3/8"	9-1/8"
2"	GUSRD058X120	5/8"	12"	GUSPLT0204	3/8"	10-1/8"
2-1/2"	GUSRD058X120	5/8"	12"	GUSPLT2503	3/8"	11-1/8"
3"	GUSRD058X120	5/8"	12"	GUSPLT2503	3/8"	11-5/8"
4"	GUSRD058X120	5/8"	12"	GUSPLT0204	3/8"	13-1/8"
5"	GUSRD058X120	5/8"	12"	GUSPLT0506	1/2"	14-1/8"
6"	GUSRD058X140	5/8"	14"	GUSPLT0506	1/2"	15-1/8"
8"	GUSRD100X170	1"	17"	GUSPLT0800	1/2"	19-1/8"
10"	GUSRD100X190	1"	19"	GUSPLT1012	3/4"	21-5/8"
12"	GUSRD100X190	1"	19"	GUSPLT1012	3/4"	24-5/8"
14"	GUSRD100X210	1"	21"	GUSPLT1400	3/4"	26-5/8"
16"	GUSRD125X215	1-1/4"	21-1/2"	GUSPLT1600	3/4"	30-1/8"
18"	GUSRD125X215	1-1/4"	21-1/2"	GUSPLT1800	3/4"	31-5/8"
20"	GUSRD125X215	1-1/4"	21-1/2"	GUSPLT2000	3/4"	34-1/8"
24"	GUSRD125X215	1-1/4"	21-1/2"	GUSPLT2400	1"	38-5/8"

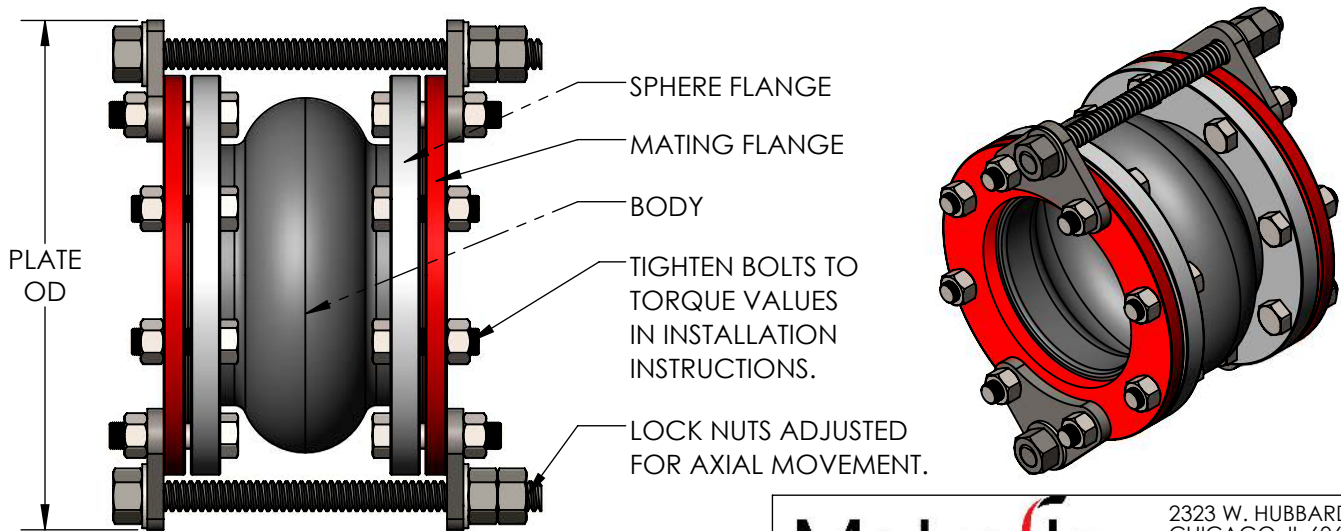

CUSTOMER: _____

PROJECT: _____

ENGINEER: _____

Metraflex
for pipes in motion

2323 W. HUBBARD ST.
CHICAGO, IL 60612
TEL: 312-738-3800
FAX: 312-738-0415
WWW.METRAFLEX.COM

CONTROL UNITS FOR MSO

DRAWN BY: DKISH	DATE: 1/5/2017
APPROVED: JC	DATE: 1/6/2017
SCALE: N/A	DRAWING NUMBER: CONTROLUNIT-MSO