

MODEL MNLC150 - SIZES 10" THROUGH 24"
LOW CORRUGATION EXPANSION JOINT, 150# CLASS

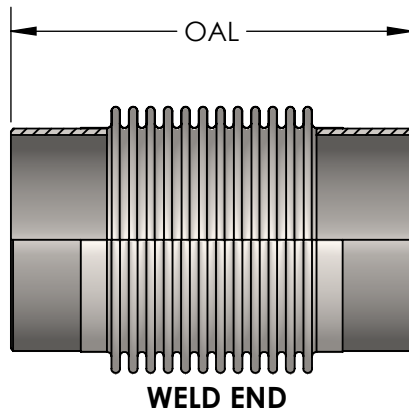
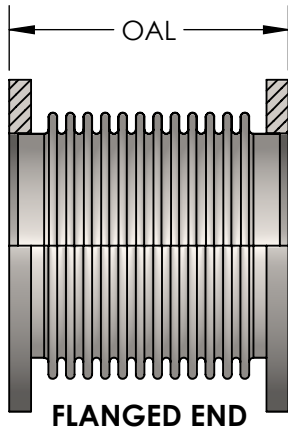

DESIGN DATA

WORKING PRESSURE: 150 PSI
 MAXIMUM OPERATING TEMPERATURE: 500°F
 TEST PRESSURE: 225 PSI

MATERIALS OF CONSTRUCTION

BELLOWS: 316 STAINLESS STEEL
 150# FLANGES: CARBON STEEL
 WELD ENDS: CARBON STEEL SCH STD

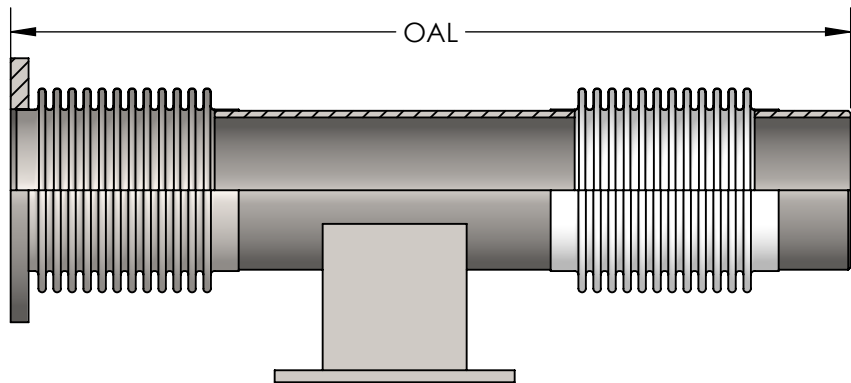

CUSTOM SIZES ARE AVAILABLE.
 CONTACT METRAFLEX FOR DETAILS.
 WHEN ORDERING, SPECIFY MOVEMENT.

DOUBLE WITH ANCHOR BASE (CONTACT FACTORY)

QTY	PIPE SIZE	SHORT / LONG	AXIAL COMP.	FLANGED ENDS		WELD ENDS		EFFECTIVE AREA	SPRING RATE
				OAL	WT	OAL	WT		
	10"	S	1-1/2"	9-3/8"	160 LBS	12-1/8"	25 LBS	104 in ²	1669 lbs/in
		L	3-1/4"	14-3/8"	170 LBS	17-1/4"	32 LBS		760 lbs/in
	12"	S	1-1/2"	9-3/4"	200 LBS	12-1/2"	35 LBS	146 in ²	1815 lbs/in
		L	3-1/8"	13-1/2"	220 LBS	16-1/4"	42 LBS		957 lbs/in
	14"	S	1-1/2"	10-3/8"	220 LBS	14-1/8"	68 LBS	183 in ²	3960 lbs/in
		L	3"	15"	240 LBS	18-3/4"	88 LBS		1990 lbs/in
	16"	S	1-1/2"	11-1/4"	232 LBS	15"	68 LBS	237 in ²	3360 lbs/in
		L	3"	16-3/4"	250 LBS	20-1/2"	86 LBS		1680 lbs/in
	18"	S	1-1/2"	11-1/2"	296 LBS	15"	71 LBS	298 in ²	5200 lbs/in
		L	3"	17"	314 LBS	20-1/2"	89 LBS		2600 lbs/in
	20"	S	1-1/2"	13-3/8"	378 LBS	15"	88 LBS	362 in ²	5600 lbs/in
		L	3"	18-7/8"	402 LBS	20-1/2"	112 LBS		2800 lbs/in
	22"	S	1-1/2"	14"	426 LBS	15"	100 LBS	434 in ²	5700 lbs/in
		L	3"	19-1/2"	454 LBS	20-1/2"	128 LBS		2850 lbs/in
	24"	S	1-1/2"	14-1/4"	495 LBS	15"	116 LBS	512 in ²	6100 lbs/in
		L	3"	19-3/4"	520 LBS	20-1/2"	150 LBS		3030 lbs/in

NSF 372 - LEAD FREE

The wetted surface of this product contacted by consumable water contains less than one quarter of one percent (0.25%) of lead by weight. Material complies with state codes and standards, where applicable, requiring reduced lead content.

CUSTOMER: _____

PROJECT: _____

ENGINEER: _____

REV. 1	ADJUST TEMP RATING	DATE 7/6/2022
		2323 W. HUBBARD ST. CHICAGO, IL 60612 TEL: 312-738-3800 FAX: 312-738-0415 WWW.METRAFLEX.COM
MODEL MNLC LOW CORRUGATION EXPANSION JOINT, 150# CLASS		
DRAWN BY: DKISH		DATE: 2/1/2018
APPROVED: JC		DATE: 2/1/2018
SCALE: NTS	DRAWING NUMBER: MNLC150-10TO24-1	