

MODEL MNLC300 - SIZES 10" THROUGH 24"
LOW CORRUGATION EXPANSION JOINT, 300# CLASS

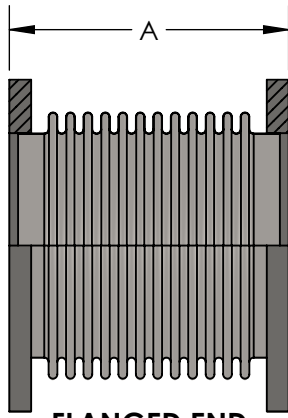

FLANGED END

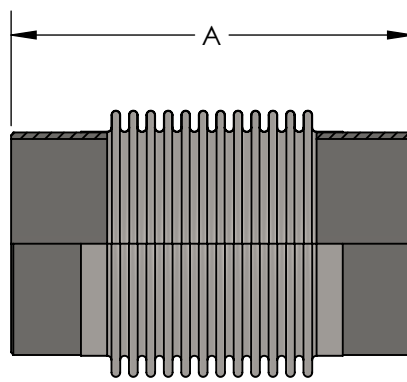

WELD END

DESIGN DATA

WORKING PRESSURE: 300 PSI
 WORKING TEMPERATURE: 800°F
 TEST PRESSURE: 450 PSI

MATERIALS OF CONSTRUCTION

BELLOWS: 316 STAINLESS STEEL
 300# FLANGES: CARBON STEEL
 WELD ENDS: CARBON STEEL SCH STD

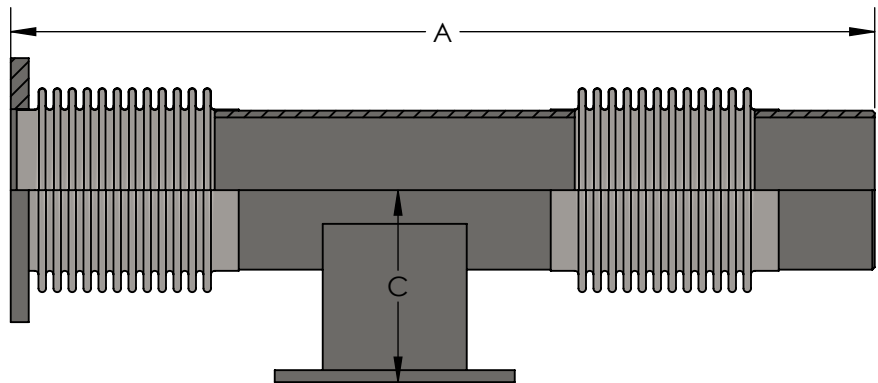

DOUBLE WITH ANCHOR BASE (CONTACT FACTORY)

CUSTOM SIZES ARE AVAILABLE.
 CONTACT METRAFLEX FOR DETAILS.
 WHEN ORDERING, SPECIFY MOVEMENT.

QTY	PIPE SIZE	SHORT / LONG	AXIAL COMP.	FLANGED ENDS		WELD ENDS		EFFECTIVE AREA	SPRING RATE
				OAL	WT	OAL	WT		
	10"	S	1"	9-3/8"	168 LBS	12-1/8"	27 LBS	104 in ²	2996 lbs/in
		L	2-1/2"	14-3/8"	179 LBS	17-1/4"	35 LBS		1226 lbs/in
	12"	S	1"	9-3/4"	210 LBS	12-1/2"	39 LBS	146 in ²	4586 lbs/in
		L	2-1/4"	13-1/2"	231 LBS	16-1/4"	46 LBS		2293 lbs/in
	14"	S	1"	10-3/8"	386 LBS	14-1/8"	132 LBS	183 in ²	5120 lbs/in
		L	2"	15"	414 LBS	18-3/4"	160 LBS		2560 lbs/in
	16"	S	1-1/2"	11-1/4"	440 LBS	15"	92 LBS	237 in ²	4240 lbs/in
		L	3"	16-3/4"	470 LBS	20-1/2"	122 LBS		2120 lbs/in
	18"	S	1-1/2"	11-1/2"	564 LBS	15"	99 LBS	298 in ²	6500 lbs/in
		L	3"	17"	598 LBS	20-1/2"	131 LBS		3240 lbs/in
	20"	S	1-1/2"	13-3/8"	710 LBS	15"	113 LBS	362 in ²	7130 lbs/in
		L	3"	18-7/8"	750 LBS	20-1/2"	173 LBS		3600 lbs/in
	22"	S	1-1/2"	14"	830 LBS	15"	152 LBS	434 in ²	11800 lbs/in
		L	3"	19-1/2"	875 LBS	20-1/2"	202 LBS		5900 lbs/in
	24"	S	1-1/2"	14-1/4"	1030 LBS	15"	180 LBS	512 in ²	12300 lbs/in
		L	3"	19-3/4"	1070 LBS	20-1/2"	220 LBS		6200 lbs/in

NSF 372 - LEAD FREE

The wetted surface of this product contacted by consumable water contains less than one quarter of one percent (0.25%) of lead by weight. Material complies with state codes and standards, where applicable, requiring reduced lead content. Not suitable for potable water systems due to materials of construction.

CUSTOMER: _____

PROJECT: _____

ENGINEER: _____

REV.	DATE
	
2323 W. HUBBARD ST. CHICAGO, IL 60612 TEL: 312-738-3800 FAX: 312-738-0415 WWW.METRAFLEX.COM	
MODEL MNLC LOW CORRUGATION EXPANSION JOINT, 300# CLASS	
DRAWN BY: DKISH	DATE: 2/1/2018
APPROVED: JC	DATE: 2/1/2018
SCALE: NTS	DRAWING NUMBER: MNLC300-10TO24-1