

**MODEL MNLC300 - SIZES 10" THROUGH 24"**  
**LOW CORRUGATION EXPANSION JOINT, 300# CLASS**

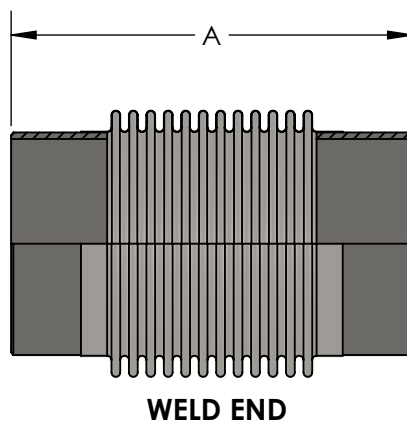
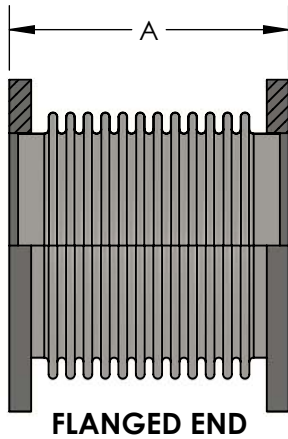

**DESIGN DATA**

WORKING PRESSURE: 300 PSI  
 WORKING TEMPERATURE: 800°F  
 TEST PRESSURE: 450 PSI

**MATERIALS OF CONSTRUCTION**

BELLOWS: 316 STAINLESS STEEL  
 300# FLANGES: CARBON STEEL  
 WELD ENDS: CARBON STEEL SCH STD

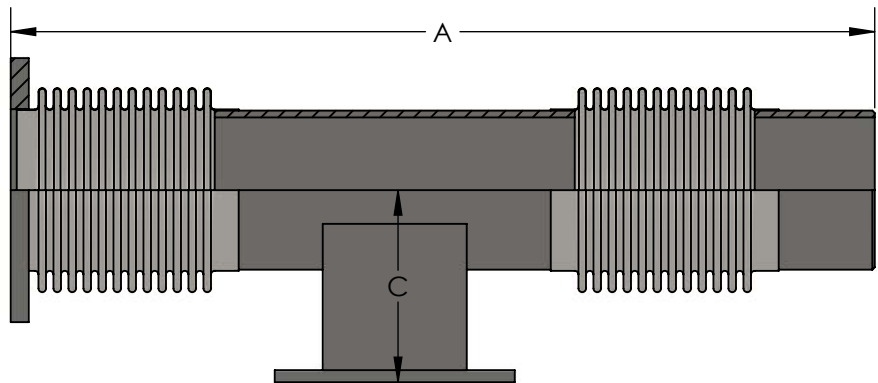

CUSTOM SIZES ARE AVAILABLE.  
 CONTACT METRAFLEX FOR DETAILS.  
 WHEN ORDERING, SPECIFY MOVEMENT.

**DOUBLE WITH ANCHOR BASE (CONTACT FACTORY)**

QTY	PIPE SIZE	SHORT / LONG	AXIAL COMP.	FLANGED ENDS		WELD ENDS		EFFECTIVE AREA	SPRING RATE
				OAL	WT	OAL	WT		
	10"	S	1"	9-3/8"	168 LBS	12-1/8"	27 LBS	104 in <sup>2</sup>	2996 lbs/in
		L	2-1/2"	14-3/8"	179 LBS	17-1/4"	35 LBS		1226 lbs/in
	12"	S	1"	9-3/4"	210 LBS	12-1/2"	39 LBS	146 in <sup>2</sup>	4586 lbs/in
		L	2-1/4"	13-1/2"	231 LBS	16-1/4"	46 LBS		2293 lbs/in
	14"	S	1"	10-3/8"	386 LBS	14-1/8"	132 LBS	183 in <sup>2</sup>	5120 lbs/in
		L	2"	15"	414 LBS	18-3/4"	160 LBS		2560 lbs/in
	16"	S	1-1/2"	11-1/4"	440 LBS	15"	92 LBS	237 in <sup>2</sup>	4240 lbs/in
		L	3"	16-3/4"	470 LBS	20-1/2"	122 LBS		2120 lbs/in
	18"	S	1-1/2"	11-1/2"	564 LBS	15"	99 LBS	298 in <sup>2</sup>	6500 lbs/in
		L	3"	17"	598 LBS	20-1/2"	131 LBS		3240 lbs/in
	20"	S	1-1/2"	13-3/8"	710 LBS	15"	113 LBS	362 in <sup>2</sup>	7130 lbs/in
		L	3"	18-7/8"	750 LBS	20-1/2"	173 LBS		3600 lbs/in
	22"	S	1-1/2"	14"	830 LBS	15"	152 LBS	434 in <sup>2</sup>	11800 lbs/in
		L	3"	19-1/2"	875 LBS	20-1/2"	202 LBS		5900 lbs/in
	24"	S	1-1/2"	14-1/4"	1030 LBS	15"	180 LBS	512 in <sup>2</sup>	12300 lbs/in
		L	3"	19-3/4"	1070 LBS	20-1/2"	220 LBS		6200 lbs/in

**NSF 372 - LEAD FREE**

The wetted surface of this product contacted by consumable water contains less than one quarter of one percent (0.25%) of lead by weight. Material complies with state codes and standards, where applicable, requiring reduced lead content.

CUSTOMER: \_\_\_\_\_

PROJECT: \_\_\_\_\_

ENGINEER: \_\_\_\_\_

REV.	DATE
	
2323 W. HUBBARD ST. CHICAGO, IL 60612 TEL: 312-738-3800 FAX: 312-738-0415 WWW.METRAFLEX.COM	
<b>MODEL MNLC</b> LOW CORRUGATION EXPANSION JOINT, 300# CLASS	
DRAWN BY: <b>DKISH</b>	DATE: <b>2/1/2018</b>
APPROVED: <b>JC</b>	DATE: <b>2/1/2018</b>
SCALE: <b>NTS</b>	DRAWING NUMBER: <b>MNLC300-10TO24-1</b>