

# MODEL LPD-MAG LOW PRESSURE DROP STRAINER WITH MAGNETIC INSERT

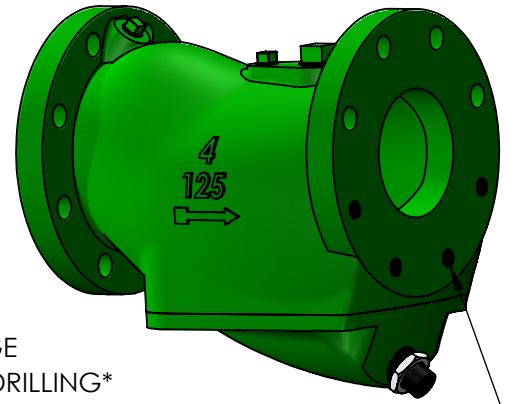
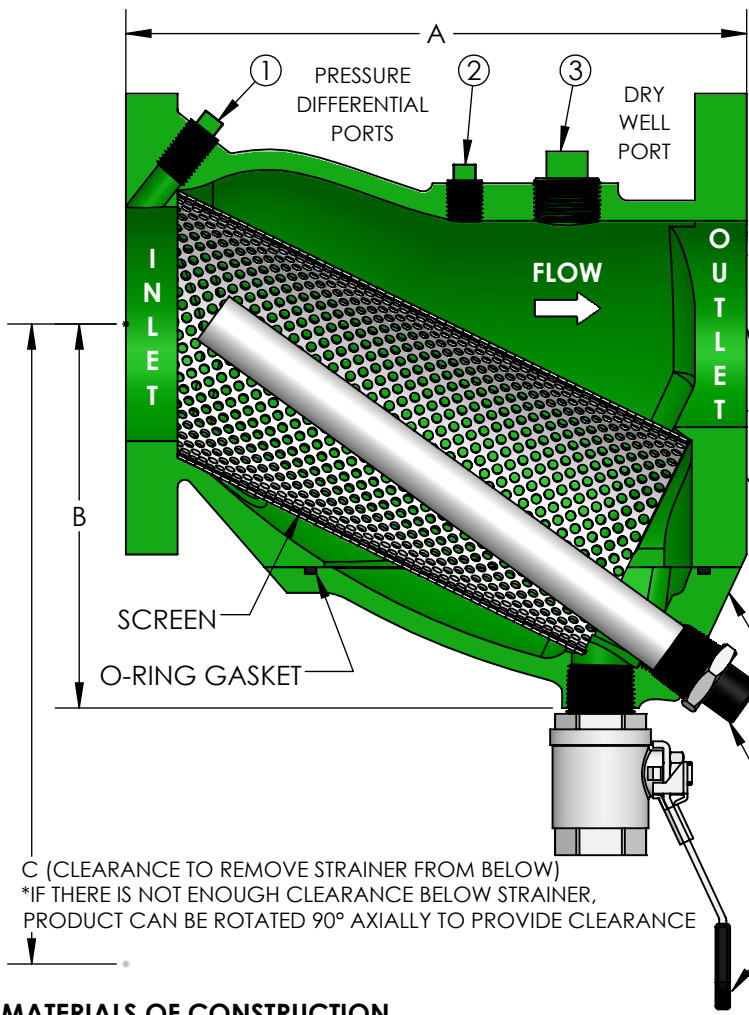

\*TAPPED BOLT HOLES  
HALF OF THE BOLT HOLES ON THE OUTLET END ARE TAPPED. SEE TAP SIZE BELOW FOR SIZING. STUDS PROVIDED FOR TAPPED HOLES.

C (CLEARANCE TO REMOVE STRAINER FROM BELOW)  
\*IF THERE IS NOT ENOUGH CLEARANCE BELOW STRAINER, PRODUCT CAN BE ROTATED 90° AXIALLY TO PROVIDE CLEARANCE

## MATERIALS OF CONSTRUCTION

BODY, FLANGES, COVER - CAST IRON  
SCREEN - 304 STAINLESS STEEL  
O-RING GASKET - VITON  
DRYWELL - 304 STAINLESS STEEL  
MAGNETS - NEODYMIUM

## STANDARD SCREENS

SERVICE	SIZE	PERF
LIQUID	2" - 3"	.045"
	4" - 8"	.125"

## OPERATING TEMPERATURE/PRESSURE

WATER, OIL, GAS.....175 PSI @ 150°F  
MAXIMUM OPERATING TEMPERATURE: 212°F

QTY	PART NUMBER	PIPE SIZE		A	B	C	#Cv (GPM)	SCREEN AREA (in <sup>2</sup> )	PORT SIZE(NPT)		BLOWOFF SIZE (NPT)	TAP SIZE (UNC)	TAP DEPTH	WEIGHT (LBS)
		INCH	MM						1 & 2	3				
	LPDMAG0200	2"	50	7-7/8"	4-5/8"	9-5/8"	120	52.0	1/4"	1/2"	1/2"	5/8"-11	1/2"	20
	LPDMAG0250	2-1/2"	65	10"	5-1/4"	11-7/8"	160	84.6	1/4"	1/2"	3/4"	5/8"-11	1/2"	30
	LPDMAG0300	3"	80	10-1/8"	6-1/4"	12-7/8"	236	99.0	1/4"	1/2"	1"	5/8"-11	7/8"	50
	LPDMAG0400	4"	100	12-1/8"	7-3/8"	15-1/4"	460	147.3	3/8"	1"	1"	5/8"-11	7/8"	75
	LPDMAG0500	5"	125	15-5/8"	8-3/8"	19"	600	226.5	3/8"	1"	1-1/2"	3/4"-10	7/8"	115
	LPDMAG0600	6"	150	18-1/2"	10-5/8"	23"	952	317.6	3/8"	1"	1-1/2"	3/4"-10	7/8"	154
	LPDMAG0800	8"	200	22-1/2"	13"	28-3/8"	1580	515.0	3/8"	1"	1-1/2"	3/4"-10	1"	273

#Cv IS THE FLOW RATE IN GALLONS OF 60°F WATER THAT WILL PASS THROUGH THE STRAINER IN 1 MINUTE AT A 1 PSI PRESSURE DROP.

### NSF 372 - LEAD FREE

The wetted surface of this product contacted by consumable water contains less than one quarter of one percent (0.25%) of lead by weight. Material complies with state codes and standards, where applicable, requiring reduced lead content.

CUSTOMER: \_\_\_\_\_

PROJECT: \_\_\_\_\_

ENGINEER: \_\_\_\_\_

5	C DIM, AND HINGE AND STUD CALLOUTS ADDED	6/27/2022
REV. 4	B DIMENSION CLARIFIED	DATE 8/20/2021
		2323 W. HUBBARD ST. CHICAGO, IL 60612 TEL: 312-738-3800 FAX: 312-738-0415 WWW.METRAFLEX.COM

## MODEL LPD-MAG

LPD STRAINER WITH MAGNETIC INSERT

DRAWN BY: DKISH	DATE: 1/24/2019
APPROVED: JC	DATE: 1/29/2019
SCALE: NTS	DRAWING NUMBER: LPDMAG-4