

**MODEL MNLC150 - SIZES 2" THROUGH 8"**  
**LOW CORRUGATION EXPANSION JOINT, 150# CLASS**

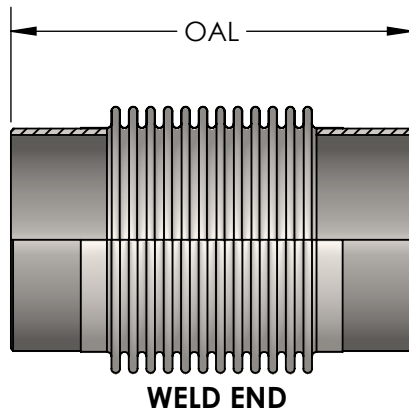
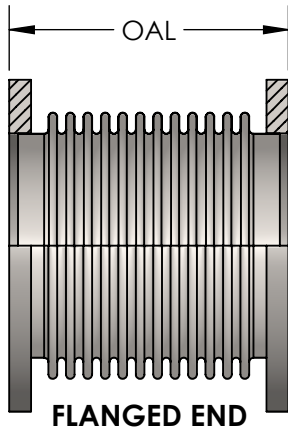

**DESIGN DATA**

WORKING PRESSURE: 150 PSI  
 MAXIMUM WORKING TEMPERATURE: 500°F  
 TEST PRESSURE: 225 PSI

**MATERIALS OF CONSTRUCTION**

BELLOWS: 316 STAINLESS STEEL  
 150# FLANGES: CARBON STEEL  
 WELD ENDS: CARBON STEEL SCH STD

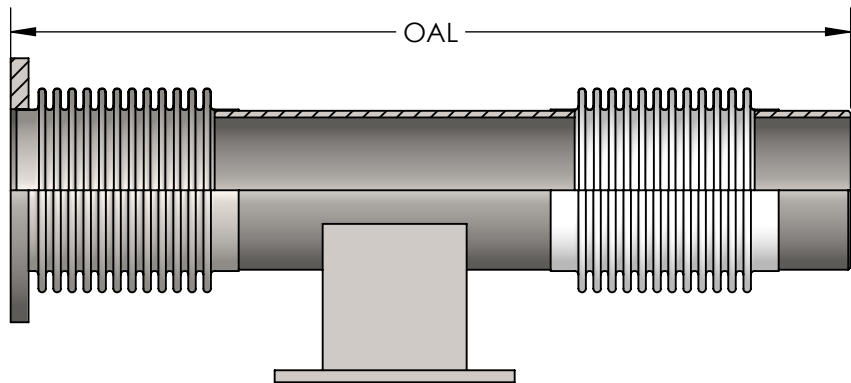

CUSTOM SIZES ARE AVAILABLE.  
 CONTACT METRAFLEX FOR DETAILS.  
 WHEN ORDERING, SPECIFY MOVEMENT.

**DOUBLE WITH ANCHOR BASE (CONTACT FACTORY)**

QTY	PIPE SIZE	SHORT / LONG	AXIAL COMP.	FLANGED ENDS		WELD ENDS		EFFECTIVE AREA	SPRING RATE
				OAL	WT	OAL	WT		
	2"	S	1-1/8"	6-1/2"	11 LBS	9-7/8"	3 LBS	6 in <sup>2</sup>	595 lbs/in
		L	1-3/4"	8-1/2"	13 LBS	11-3/4"	4 LBS		320 lbs/in
	2-1/2"	S	1"	7"	14 LBS	9-7/8"	3 LBS	9 in <sup>2</sup>	498 lbs/in
		L	1-3/4"	8-7/8"	16 LBS	11-3/4"	4 LBS		299 lbs/in
	3"	S	1"	7-3/8"	20 LBS	10-1/2"	5 LBS	12 in <sup>2</sup>	349 lbs/in
		L	2"	9"	21 LBS	12"	6 LBS		240 lbs/in
	4"	S	1-1/4"	7-1/2"	35 LBS	10-5/8"	8 LBS	19 in <sup>2</sup>	803 lbs/in
		L	2-1/2"	10-3/4"	38 LBS	13-3/4"	9 LBS		406 lbs/in
	5"	S	1-1/4"	7-5/8"	45 LBS	10-5/8"	13 LBS	29 in <sup>2</sup>	987 lbs/in
		L	2-1/2"	11-1/4"	49 LBS	14-1/4"	15 LBS		480 lbs/in
	6"	S	1-1/4"	8"	85 LBS	11"	18 LBS	40 in <sup>2</sup>	1181 lbs/in
		L	2-1/2"	11-1/2"	90 LBS	14-1/2"	20 LBS		555 lbs/in
	8"	S	1-1/2"	9-1/4"	120 LBS	12-1/8"	22 LBS	66 in <sup>2</sup>	1235 lbs/in
		L	3"	13-1/4"	125 LBS	16-1/8"	26 LBS		620 lbs/in

**NSF 372 - LEAD FREE**

The wetted surface of this product contacted by consumable water contains less than one quarter of one percent (0.25%) of lead by weight. Material complies with state codes and standards, where applicable, requiring reduced lead content.

CUSTOMER: \_\_\_\_\_

PROJECT: \_\_\_\_\_

ENGINEER: \_\_\_\_\_

REV.	1	ADJUST TEMP RATING	DATE 7/6/2022
		2323 W. HUBBARD ST. CHICAGO, IL 60612 TEL: 312-738-3800 FAX: 312-738-0415 WWW.METRAFLEX.COM	
		<b>MODEL MNLC</b> LOW CORRUGATION EXPANSION JOINT, 150# CLASS	
DRAWN BY: <b>DKISH</b>		DATE: <b>2/1/2018</b>	
APPROVED: <b>JC</b>		DATE: <b>2/1/2018</b>	
SCALE: <b>NTS</b>		DRAWING NUMBER: <b>MNLC150-2TO8-1</b>	