

MODEL MNLC50 - SIZES 10" THROUGH 24"
LOW CORRUGATION EXPANSION JOINT, 50# CLASS

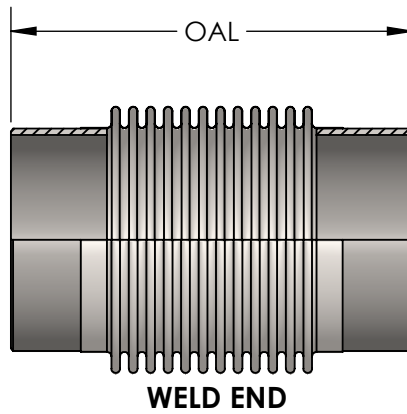
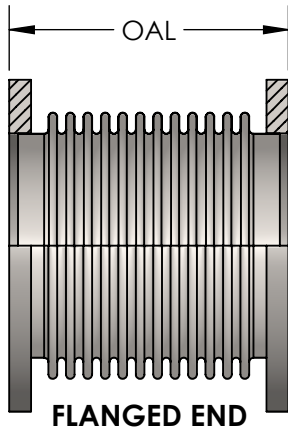

DESIGN DATA

WORKING PRESSURE: 50 PSI
 MAXIMUM OPERATING TEMPERATURE: 500°F
 TEST PRESSURE: 75 PSI

MATERIALS OF CONSTRUCTION

BELLOWS: 316 STAINLESS STEEL
 150# FLANGES: CARBON STEEL
 WELD ENDS: CARBON STEEL SCH STD

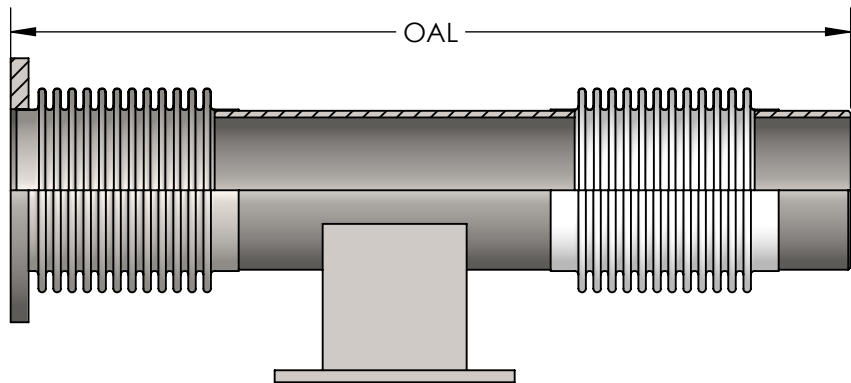

CUSTOM SIZES ARE AVAILABLE.
 CONTACT METRAFLEX FOR DETAILS.
 WHEN ORDERING, SPECIFY MOVEMENT.

DOUBLE WITH ANCHOR BASE (CONTACT FACTORY)

QTY	PIPE SIZE	SHORT / LONG	AXIAL COMP.	FLANGED ENDS		WELD ENDS		EFFECTIVE AREA	SPRING RATE
				OAL	WT	OAL	WT		
	10"	S	1-1/2"	9-3/8"	45 LBS	12-1/8"	25 LBS	104 in ²	1655 lbs/in
		L	3-3/8"	14-3/8"	52 LBS	17-1/4"	32 LBS		750 lbs/in
	12"	S	1-1/2"	9-3/4"	70 LBS	12-1/2"	35 LBS	146 in ²	784 lbs/in
		L	3-1/4"	13-1/2"	85 LBS	16-1/4"	42 LBS		435 lbs/in
	14"	S	1-3/4"	10-3/8"	98 LBS	14-1/8"	56 LBS	183 in ²	2200 lbs/in
		L	3-1/2"	15"	112 LBS	18-3/4"	70 LBS		1100 lbs/in
	16"	S	1-3/4"	11-1/4"	112 LBS	15"	62 LBS	237 in ²	1720 lbs/in
		L	3-1/2"	16-3/4"	127 LBS	20-1/2"	77 LBS		860 lbs/in
	18"	S	1-3/4"	11-1/2"	112 LBS	15"	57 LBS	298 in ²	1640 lbs/in
		L	3-1/2"	17"	123 LBS	20-1/2"	68 LBS		820 lbs/in
	20"	S	1-3/4"	13-3/8"	130 LBS	15"	72 LBS	362 in ²	1960 lbs/in
		L	3-1/2"	18-7/8"	146 LBS	20-1/2"	88 LBS		980 lbs/in
	22"	S	1-3/4"	14"	140 LBS	15"	78 LBS	434 in ²	2040 lbs/in
		L	3-1/2"	19-1/2"	157 LBS	20-1/2"	95 LBS		1020 lbs/in
	24"	S	1-3/4"	14-1/4"	220 LBS	15"	88 LBS	512 in ²	2460 lbs/in
		L	3-1/2"	19-3/4"	240 LBS	20-1/2"	108 LBS		1230 lbs/in

NSF 372 - LEAD FREE

The wetted surface of this product contacted by consumable water contains less than one quarter of one percent (0.25%) of lead by weight. Material complies with state codes and standards, where applicable, requiring reduced lead content.

CUSTOMER: _____

PROJECT: _____

ENGINEER: _____

REV. 1	ADJUST TEMP RATING	DATE 7/6/2022
		2323 W. HUBBARD ST. CHICAGO, IL 60612 TEL: 312-738-3800 FAX: 312-738-0415 WWW.METRAFLEX.COM
MODEL MNLC LOW CORRUGATION EXPANSION JOINT, 50# CLASS		
DRAWN BY: DKISH		DATE: 2/1/2018
APPROVED: JC		DATE: 2/1/2018
SCALE: NTS	DRAWING NUMBER: MNLC50-10TO24-1	