

# Combat high pressure and temperature with the **MetraPak** expansion joint.

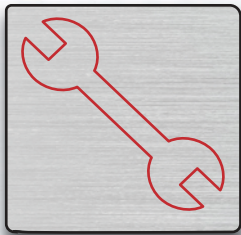

Expert engineering design services available for any application

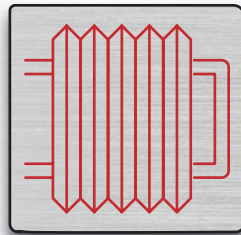

Unique design capable of absorbing large amounts of axial movement

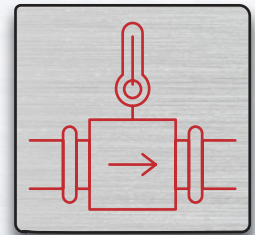

Absorb thermal expansion in pipelines and process systems

**Metraflex.**  
*for pipes in motion*

2323 W HUBBARD ST. CHICAGO, IL 60612 • (312) 738-3800  
[WWW.METRAFLEX.COM/METRAPAK](http://WWW.METRAFLEX.COM/METRAPAK)

# Single MetraPak – Flanged Ends

Dimensions 150 lbs.

Dimensions 300 lbs.

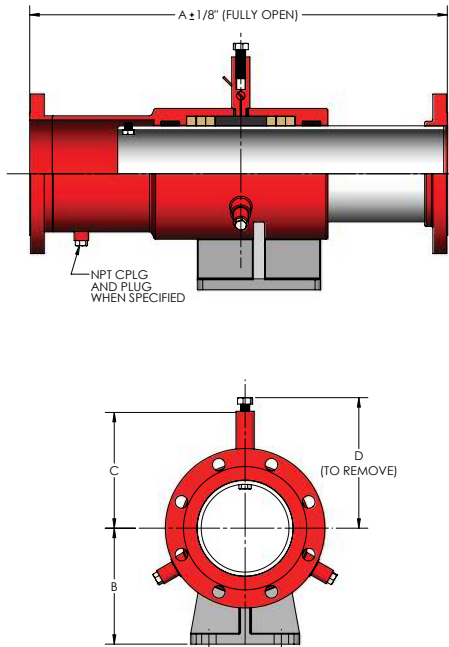

Size	FLANGED			B	C	D
	A-Traversal					
	4"	8"	12"			
1 ¼	18 7/8	26 7/8	34 7/8	3 5/8	5 3/16	8 1/16
1 ½	19	27	35	3 3/4	5 1/4	8 1/8
2	19 ¼	27 ¼	35 ¼	4 1/8	5 9/16	8 7/16
2 ½	19 ¼	27 ½	35 ½	4 ½	5 7/8	8 3/4
3	21 7/8	29 7/8	37 7/8	4 7/8	6 ¼	9 1/8
3 ½	22	30	38	5 ¼	6 ½	9 3/8
4	22 ½	30 ½	38 ½	5 ½	6 ¾	9 5/8
5	22 5/8	30 5/8	38 5/8	6 ¼	7 3/8	10 ¼
6	23	31	39	7	7 7/8	10 ¾
8	23 3/8	31 3/8	39 3/8	8 3/8	8 ¾	11 5/8
10	23 ¾	31 3/8	39 ¾	9 ¾	9 7/8	12 ¾
12	24 ½	32 ½	40 ½	11	11	13 4/5
14	27 ¼	35 ¼	43 ¼	11 ½	11 ¾	14 5/8
16	27 7/8	35 7/8	43 7/8	12 ¾	12 ¾	15 5/8
18	28 3/8	36 3/8	44 3/8	13 ½	13 ¾	16 5/8
20	28 ¾	36 ¾	44 ¾	14 ¾	14 ¾	17 5/8
24	29 ½	37 ½	45 ½	17	16 ¾	19 5/8

Size	FLANGED			B	C	D
	A-Traversal					
	4"	8"	12"			
1 ¼	19 3/8	27 3/8	35 3/8	3 5/8	6 1/16	9 ½
1 ½	19 5/8	27 5/8	35 5/8	3 ¾	6 ¾	9 9/16
2	19 ¾	27 ¾	35 ¾	4 1/8	7 1/16	9 7/8
2 ½	20 1/8	28 1/8	36 1/8	5	7 3/8	10 3/16
3	22 ¾	30 ¾	38 ¾	4 7/8	7 ¾	10 9/16
3 ½	22 7/8	30 7/8	38 7/8	5 ¼	8	10 13/16
4	23 ¼	31 ¼	39 ¼	5 ½	8 ¼	11 1/16
5	23 ¾	31 ¾	39 ¾	6 ¼	8 7/8	11 1/16
6	24	32	40	7	9 3/8	12 3/16
8	24 ¾	32 ¾	40 ¾	8 3/8	10 ¼	13 1/16
10	25 1/8	33 1/8	41 1/8	9 ¾	11 3/8	14 3/16
12	25 7/8	33 7/8	41 7/8	11	12 7/16	15 ¼
14	28 ¾	36 ¾	44 ¾	12 ½	13 ¼	16 1/16
16	29 3/8	37 3/8	45 3/8	13 ½	14 ¼	17 1/16
18	30	38	46	15	15 ¼	18 1/16
20	30 ½	38 ½	46 ½	16 ¼	16 ¼	19 1/16
24	31 3/8	39 3/8	47 3/8	19	18 ¼	21 1/16

# Single MetraPak – Weld Ends

Dimensions 150 lbs.

Dimensions 300 lbs.

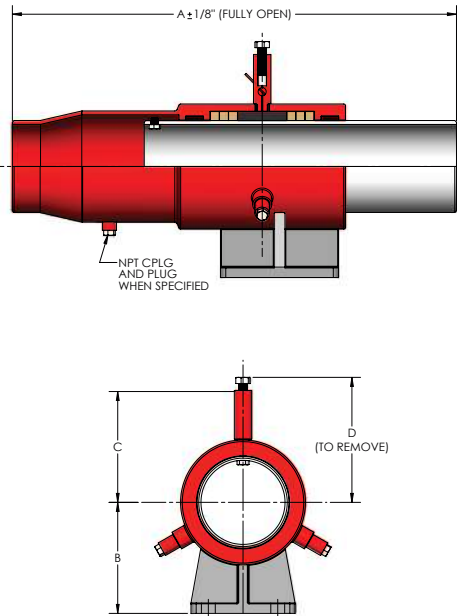

Size	WELD ENDS			B	C	D
	A-Traversal					
	4"	8"	12"			
1 ¼	23 3/8	31 3/8	39 3/8	3 5/8	5 3/16	8 1/16
1 ½	23 3/8	31 7/8	39 7/8	3 ¾	5 ¼	8 1/8
2	23 3/8	31 7/8	39 7/8	4 1/8	5 9/16	8 7/16
2 ½	24 3/8	32 3/8	40 3/8	4 ½	5 7/8	8 ¾
3	21 7/8	29 7/8	37 7/8	4 7/8	6 ¼	9 1/8
3 ½	22	30	38	5 ¼	6 ½	9 3/8
4	22 ½	30 ½	38 ½	5 ½	6 ¾	9 5/8
5	22 5/8	30 5/8	38 5/8	6 ¼	7 3/8	10 ¼
6	23	31	39	7	7 7/8	10 ¾
8	23 3/8	31 3/8	39 3/8	8 3/8	8 ¾	11 5/8
10	23 ¾	31 3/8	39 ¾	9 ¾	9 7/8	12 ¾
12	24 ½	32 ½	40 ½	11	11	13 4/5
14	27 ¼	35 ¼	43 ¼	11 ½	11 ¾	14 5/8
16	27 7/8	35 7/8	43 7/8	12 ¾	12 ¾	15 5/8
18	28 3/8	36 3/8	44 3/8	13 ½	13 ¾	16 5/8
20	28 ¾	36 ¾	44 ¾	14 ¾	14 ¾	17 5/8
24	29 ½	37 ½	45 ½	17	16 ¾	19 5/8

Size	WELD ENDS			B	C	D
	A-Traversal					
	4"	8"	12"			
1 ¼	23 3/8	31 3/8	39 3/8	3 5/8	6 1/16	9 ½
1 ½	23 3/8	31 7/8	39 7/8	3 ¾	6 ¾	9 9/16
2	23 3/8	31 7/8	39 7/8	4 1/8	7 1/16	9 7/8
2 ½	24 3/8	32 3/8	40 3/8	4 ½	7 3/8	10 3/16
3	26 5/8	34 5/8	42 5/8	4 7/8	7 ¾	10 9/16
3 ½	27 5/8	35 5/8	43 5/8	5 ¼	8	10 13/16
4	27 ¾	35 ¾	43 ¾	5 ½	8 ¼	11 1/16
5	28 ½	36 ½	44 ½	6 ¼	8 7/8	11 1/16
6	27 1/8	35 1/8	43 1/8	7	9 3/8	12 3/16
8	27 1/8	35 1/8	43 1/8	8 3/8	10 ¼	13 1/16
10	27 1/8	35 1/8	43 1/8	9 ¾	11 3/8	14 3/16
12	27 3/8	35 3/8	43 3/8	11	12 7/16	15 ¼
14	30	38	46	12 ½	13 ¼	16 1/16
16	30 1/8	38 1/8	46 1/8	13 ½	14 ¼	17 1/16
18	30 ¼	38 ¼	46 ¼	15	15 ¼	18 1/16
20	30 ¼	38 ¼	46 ¼	16 ¼	16 ¼	19 1/16
24	30 ¼	38 ¼	46 ¼	19	18 ¼	21 1/16



2323 W HUBBARD ST. CHICAGO, IL 60612 • (312) 738-3800

WWW.METRAFLEX.COM/METRAPAK