

EX30 EXHAUST PIPE EXPANSION JOINT, 150 LB. FIXED x FLOATING FLANGES

MAX. OPERATING 5 PSI, 1000°F

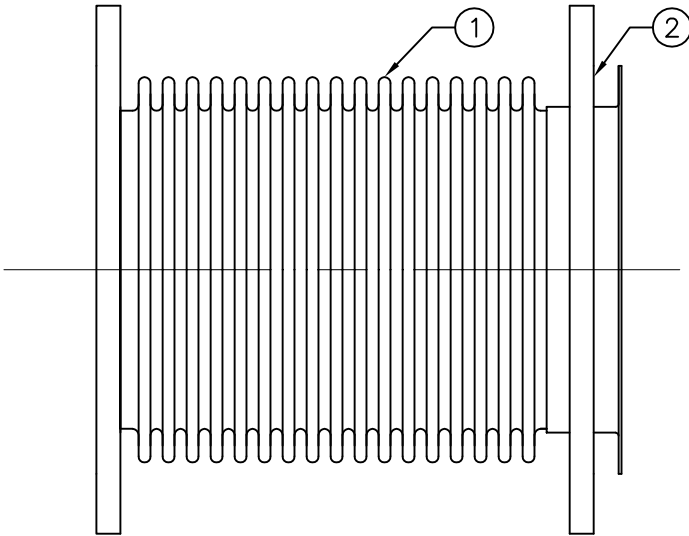

MATERIALS		
①	BELLOWS	STAINLESS STEEL
②	FLANGE	CARBON STEEL*

* STAINLESS STEEL ENDS AVAILABLE, MAX OPERATING TEMP. IS 1200°F.

QTY	PIPE SIZE	ID (in)	OAL (in)	AXIAL COMP. (in)	LATERAL OFFSET (in)	AXIAL SPRING RATE (lb/in)	LATERAL SPRING RATE (lb/in)	WEIGHT (lb)
	4	4.50	12.00	3	1	46	22	17
	5	5.56	12.00	3	1	66	47	20
	6	6.63	12.00	3	1	82	80	23
	8	8.63	12.00	3	1	103	165	31
	10	10.75	12.00	3	1	103	248	39
	12	12.75	12.00	3	.875	121	405	55
	14	14.00	12.00	3	.750	132	530	66
	16	16.00	12.00	3	.625	150	777	77
	18	18.00	12.00	3	.500	168	1092	80
	20	20.00	12.00	3	.500	186	1480	93
	22	22.00	12.00	3	.500	204	1952	97
	24	24.00	12.00	3	.500	222	2513	124

3	09/18/2013	REV. SPRING RATES, LATERAL OFFSETS
2	09/14/2011	ADDED STAINLESS NOT TO MATERIALS TABLE
1	06/03/2011	REV. SPRING RATES, WEIGHTS ADDED
REV.	DATE	DESCRIPTION

Metraflex
for pipes in motion

2323 W. HUBBARD ST.
CHICAGO, IL 60612
TEL: 312-738-3800
FAX: 312-738-0415
WWW.METRAFLEX.COM

DESCRIPTION: EXHAUST BELLOWS, FIXED x FLOATING FLANGES

DRAWN BY: MIR DATE: 09/18/2013

APPROVED: KG DATE: 09/18/2013

SCALE: NONE DRAWING NUMBER: EX30

CUSTOMER: _____

PROJECT: _____

ENGINEER: _____