

C (HEIGHT ABOVE FACE
WHEN DISCS ARE FULLY OPEN)

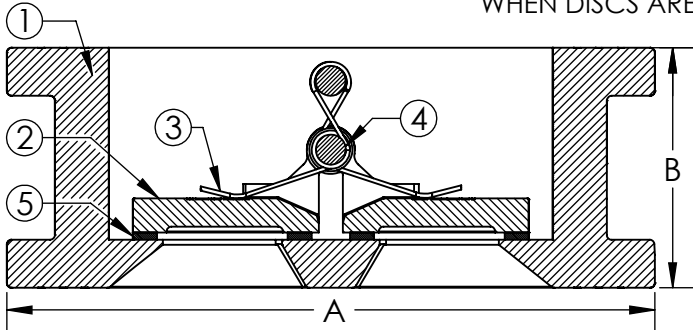

MAX NON-SHOCK WORKING PSI

SIZE	150°F	200°F
2" TO 12"	200 PSI	190 PSI
14" AND UP	150 PSI	135 PSI

NSF 372 - LEAD FREE

The wetted surface of this product contacted by consumable water contains less than one quarter of one percent (0.25%) of lead by weight. Material complies with state codes and standards, where applicable, requiring reduced lead content. Not suitable for potable water systems due to materials of construction.

Notes:

Valve is designed for liquid service only. Install 5 to 10 pipe diameters downstream from pump discharge or elbows. To avoid turbulence, use with a VANEFLEX connector.

Valve is designed to be mated to ANSI B16.5 steel flanges.

For vertical pipe, install with flow up. For horizontal pipe, install with hinge pin in vertical position.

ITEM	PART NAME	MATERIAL
1	BODY	EPOXY COATED CAST IRON
2	DISC	STAINLESS STEEL
3	SPRING	STAINLESS STEEL
4	SHAFT	STAINLESS STEEL
5	SEAT	EPDM
6	WASHER	PTFE
7	SEAL	NBR
8	SET SCREW	STAINLESS STEEL

Qty.	Part Number	Size I.D. (in)	A (in)	B (in)	C (in)	Cv*	Weight (Lbs)	Bolt Size (in)	Project Info
	CVXXK0200	2	4	1-3/4	1/4	48	3	5/8	
	CVXXK0250	2-1/2	4-3/4	1-7/8	5/8	99	5	5/8	
	CVXXK0300	3	5-1/4	2-1/2	1/2	171	8	5/8	
	CVXXK0400	4	6-3/4	2-1/2	1-1/8	290	13	5/8	
	CVXXK0500	5	7-5/8	2-3/4	1-3/8	489	16	3/4	
	CVXXK0600	6	8-5/8	3	1-5/8	695	20	3/4	
	CVXXK0800	8	10-7/8	3-1/2	2-7/8	1789	38	3/4	
	CVXXK1000	10	13-1/4	4-1/2	3	2557	57	7/8	
	CVXXK1200	12	16	4-1/2	4-5/8	4287	93	7/8	
	CVXXK1400	14	17-5/8	5	5	5456	121	1	
	CVXXK1600	16	20	5-1/2	5-3/4	7342	165	1	
	CVXXK1800	18	21-1/2	6	6-3/8	9532	223	1-1/8	
	CVXXK2000	20	23-3/4	6	7-1/8	12000	245	1-1/8	

*Cv is the number of U.S. gallons/minute of 60°F water that will flow through a valve with 1 PSI of pressure drop across the valve.



FOR ADDITIONAL FLOW STRAIGHTENING
SEE THE VANEFLEX AT
www.metraflex.com/vaneflex

CUSTOMER: _____

PROJECT: _____

ENGINEER: _____

REV.	DATE
2323 W. HUBBARD ST. CHICAGO, IL 60612 TEL: 312-738-3800 FAX: 312-738-0415 WWW.METRAFLEX.COM	
<h2>MODEL CVXXK</h2>	
125# SPLIT DISC WAFER STYLE CHECK VALVE	
DRAWN BY: DKISH	DATE: 8/27/2013
APPROVED: JC	DATE: 8/27/2013
SCALE: NONE	DRAWING NUMBER: CVXXK-EP