

**DOUBLE MIGHTYSPHERE MODEL DSKSEE, KEVLAR REINFORCED
EPDM EXPANSION JOINT, 150# FLANGED**

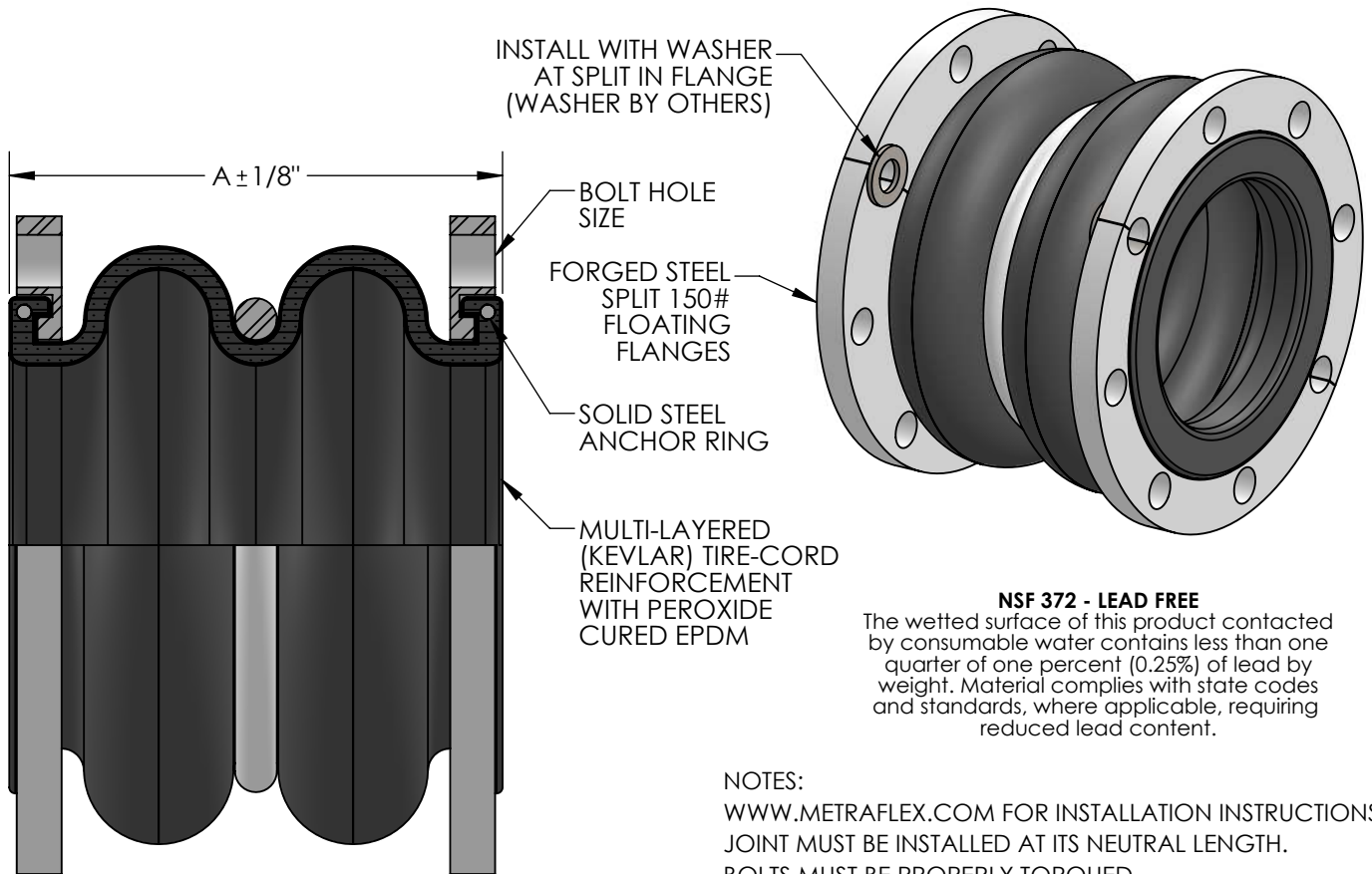

NSF 372 - LEAD FREE

The wetted surface of this product contacted by consumable water contains less than one quarter of one percent (0.25%) of lead by weight. Material complies with state codes and standards, where applicable, requiring reduced lead content.

NOTES:

WWW.METRAFLEX.COM FOR INSTALLATION INSTRUCTIONS.
JOINT MUST BE INSTALLED AT ITS NEUTRAL LENGTH.
BOLTS MUST BE PROPERLY TORQUED.
NOT SUITABLE FOR STEAM OR FULL VACUUM APPLICATIONS.
IF CONNECTING PIPE IS NOT ANCHORED AND GUIDED,
CONTROL UNITS MUST BE USED.

QTY	PART NUMBER	PIPE SIZE		A	AXIAL COMP.	AXIAL EXT.	LATERAL OFFSET	ANGULAR	SPRING RATE (LBS/IN)	WEIGHT (LBS)	BOLT HOLE SIZE
		INCH	MM								
	DSKSEE0200	2"	50	7"	2"	9/16"	3/4"	34°	160	10	3/4"
	DSKSEE0250	2-1/2"	65	7"	2"	9/16"	3/4"	32°	310	13	3/4"
	DSKSEE0300	3"	80	7"	2"	9/16"	3/4"	30°	320	14	3/4"
	DSKSEE0400	4"	100	9"	2"	9/16"	11/16"	28°	450	15	3/4"
	DSKSEE0500	5"	125	9"	2"	9/16"	11/16"	24°	360	24	7/8"
	DSKSEE0600	6"	150	9"	2"	9/16"	11/16"	22°	760	33	7/8"
	DSKSEE0800	8"	200	13"	2-3/8"	9/16"	11/16"	20°	1030	48	7/8"
	DSKSEE1000	10"	250	13"	2-3/8"	9/16"	11/16"	18°	680	65	1"
	DSKSEE1200	12"	300	13"	2-3/8"	9/16"	11/16"	16°	950	103	1"

MAXIMUM OPERATING CONDITIONS

TEMPERATURE	PRESSURE
170°F	250 PSI
190°F	245 PSI
210°F	235 PSI
230°F	225 PSI
250°F	215 PSI

MAXIMUM WORKING TEMPERATURE 250°F

TO BE FURNISHED WITH CONTROL UNITS:

YES NO

REV.	DATE
	
2323 W. HUBBARD ST. CHICAGO, IL 60612 TEL: 312-738-3800 FAX: 312-738-0415 WWW.METRAFLEX.COM	
DOUBLE MIGHTYSPHERE MODEL DSKSEE	
EPDM EXPANSION JOINT, 150# FLANGES	
DRAWN BY: DKISH	DATE: 7/20/2018
APPROVED:	DATE:
SCALE: N/A	DRAWING NUMBER: DSKSEE-1

CUSTOMER: _____

PROJECT: _____

ENGINEER: _____