

PART NO.	NAME	MATERIAL
1	BODY	CAST IRON ASTM A48, CLASS 35
2	SEAT W/ BUNA N	BRONZE ASTM B584, COPPER ALLOY 836
3	PLUG	BRONZE ASTM B584, COPPER ALLOY 836
5	BUSHING	BRONZE ASTM B584, COPPER ALLOY 932
6	RETAINING SCREWS	STAINLESS STEEL T304-ASTM A276
7	BUSHING RETAINER	BRONZE - ASTM B16
8	GASKET	NON ASBESTOS DURALON GREY OR EQUAL
9	SCREEN RETAINER	STAINLESS STEEL T304-ASTM A276
10	RING PLATE	CARBON STEEL ASTM A36
11	BOLT ASSEMBLY	STEEL #1035 H.T.
12	SCREEN	STAINLESS STEEL T304-ASTM A240

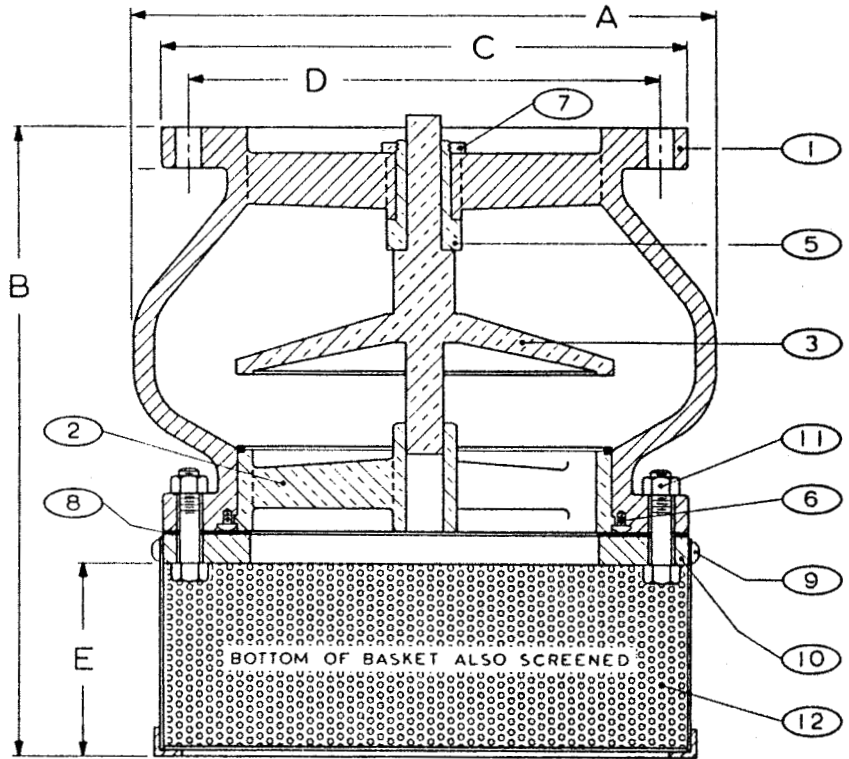

QTY.	VALVE SIZE		MODEL NO.	A	B	C	D	E	WEIGHT
	INCH	MM							
	2	25	F902	6	9 3/4"	4 3/4"	11/16	3 5/8"	33
	2 1/2	65	F902.5	7	9 3/4"	5 1/2"	11/16	3 5/8"	33
	3	80	F903	7 1/2"	9 1/2"	6"	15/16"	3"	37
	4	100	F904	9"	11"	7 1/2"	15/16"	3"	57
	5	125	F905	10"	13 1/4"	8 1/2"	15/16"	4"	70
	6	150	F906	11"	15 3/4"	9 1/2"	1"	5"	90
	8	200	F908	13 1/2"	19 1/2"	11 3/4"	1 1/8"	6"	153
	10	250	F910	16"	23 1/2"	14 1/4"	1 3/16"	7"	226
	12	300	F912	20"	23 1/4"	19"	17"	8"	370
	14	350	F914	22"	25 3/4"	21"	18 3/4"	9"	465
	16	400	F916	25"	28 7/8"	23 1/2"	21 1/4"	10"	594
	18	450	F918	28"	31"	25"	22 3/4"	11"	844
	20	500	F920	31"	34 7/8"	27 1/2"	25"	13"	1045
	24	600	F924	37"	41 1/2"	32"	29 1/2"	16"	1430
	30	750	F930	45"	50 3/4"	38 3/4"	36"	20"	2220

CUSTOMER \_\_\_\_\_

PROJECT \_\_\_\_\_

ENGINEER \_\_\_\_\_

ARCHITECT \_\_\_\_\_

PRO OR P.O. NO. \_\_\_\_\_

**the Metraflex® company**  
CHICAGO ILLINOIS

DESCRIPTION:

**FOOT VALVE  
125# ANSI FLANGE**

DRAWN BY:

JRR

DATE:

5-04-94

DRAWING:

CVF900