

# 711 FRP Expansion Joint

**Designed  
Specifically**  
for Plastic, FRP, Fiberglass,  
ABS, CPVC, HDPE, Glass  
Piping

**This is the expansion  
joint you want to use  
for plastic/FRP piping!**

- Integral Gusset Plates: eliminate point loading on mating flanges
- Multiple Tie Rods: distribute thrust load
- Full Faced Flanges: low, even sealing force
- Wide Arch Construction: 1-3/4 to 2 inches of axial compression
- "L" shaped back up flanges: external body reinforcement allows for a more flexible joint
- EPDM or Butyl are standard: other elastomer materials are available

**Metraflex**  
*for pipes in motion*

**BAD**



# STYLE 711 FRP WIDE ARCH EXPANSION JOINT FOR FIBERGLASS AND PLASTIC PIPE

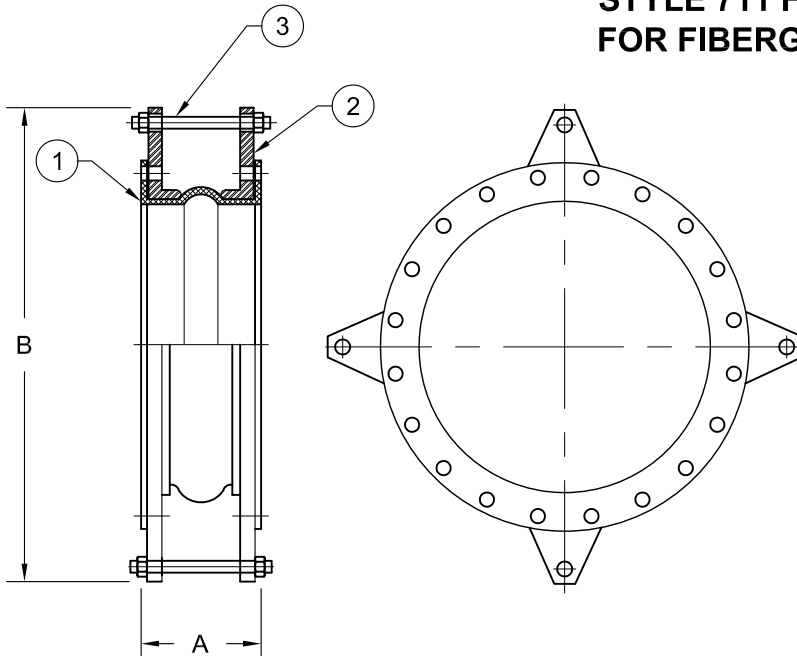

**NOTE:**  
THIS FLEXIBLE JOINT SHOULD BE INSTALLED THE LENGTH SHOWN ON DRAWING. PIPING AND EQUIPMENT CONNECTED BY THIS FLEXIBLE JOINT SHOULD BE ANCHORED AND GUIDED. NOT INTENDED FOR TORSION.

ITEM	NAME	MATERIAL
1	BODY	EPDM
2	RETAINING RING	DUCTILE IRON
3	CONTROL ROD GALVANIZED	C/S

**MAXIMUM WORKING TEMPERATURE: 230°**

PIPE SIZE	NO. OF CONTROL RODS
2" - 5"	3
6" - 10"	4
12" - 24"	6

## MOVEMENT CAPABILITY AND FORCES @ 0 PSI\*

QTY.	SIZE (NPS)	A F/F (IN.)	B (IN.)	PRESSURE (PSIG)	VACUUM (IN. HG.)	COMPRESSION		ELONGATION		LATERAL		ANGULAR	EFFECTIVE AREA (SQ IN.)	WEIGHT (LB)
						MAX DEFL (IN.)	SPRING RATE (LB/IN.)	MAX DEFL (IN.)	SPRING RATE (LB/IN.)	MAX DEFL (IN.)	SPRING RATE (LB/IN.)	MAX DEFL (DEG.)		
	2"	6	8-1/2"	150	10	1-3/4	126	3/4	160	3/4	213		14	7
	2-1/2"	6	9-3/8"	150	10	1-3/4	160	3/4	200	3/4	227		17	9
	3"	6	10"	150	10	1-3/4	189	3/4	240	3/4	253		21	10
	4"	6	11-1/8"	150	10	1-3/4	257	3/4	333	3/4	280		36	11
	5"	6	13"	150	10	1-3/4	314	3/4	413	3/4	333		50	14
	6"	6	14"	150	10	1-3/4	383	3/4	493	1	370		66	18
	8"	6	16-1/2"	150	10	1-3/4	423	3/4	547	1	450	**	101	25
	10"	8	19"	150	10	1-3/4	531	3/4	693	1	480		145	36
	12"	8	22"	150	10	1-3/4	554	3/4	733	1	570		199	48
	14"	8	28"	150	10	2	595	7/8	766	1-1/8	667		260	60
	16"	8	32"	150	10	2	635	7/8	823	1-1/8	773		329	68
	18"	8	33"	150	10	2	715	7/8	926	1-1/8	853		403	77
	20"	8	36"	150	10	2	795	7/8	1029	1-1/8	951		482	77
	24"	8	40"	150	10	2	1070	7/8	1417	1-1/8	1022		695	120

**\*CALCULATING ANCHOR/THRUST LOADS:**

MULTIPLY THE GREATER OF THE MAXIMUM SYSTEM TEST PRESSURE OR OPERATING PRESSURE TIMES THE EFFECTIVE AREA TO OBTAIN THE FORCE THAT WILL BE EXERTED BY THE PRESSURIZED EXPANSION JOINT ON THE ADJACENT PIPING. ANCHORS MUST BE STRONGER THAN THIS FORCE IF THE JOINT IS TO COMPRESS AND COMPENSATE FOR THE PIPE'S THERMAL EXPANSION. PIPE GUIDES WILL BE NECESSARY TO DIRECT MOVEMENT OF THE PIPE'S EXPANSION.

**\*\*DUE TO UNEVEN LOADING OF TIE RODS FACTORY MUST BE CONSULTED.**

CUSTOMER: \_\_\_\_\_  
PROJECT: \_\_\_\_\_  
ENGINEER: \_\_\_\_\_

REV.	DATE	
		2323 W. HUBBARD ST. CHICAGO, IL 60612 TEL:312-738-3800 FAX:312-738-0415 WWW.METRAFLEX.COM
		DESCRIPTION: STYLE 711 FRP WIDE ARCH EXPANSION JOINT
DRAWN BY: AD	DATE: 01/12/2010	
APPROVED: MR	DATE: 01/12/2010	
SCALE: NONE	DRAWING NUMBER: 711 FRP	