

**150# CARBON STEEL
SLIP-ON PLATE FLANGES**

MATERIAL: ASTM A36

ALL SURFACES TO BE MACHINED (ID, OD, AND BOTH FACES) AND COATED WITH A RUST PROHIBITIVE.

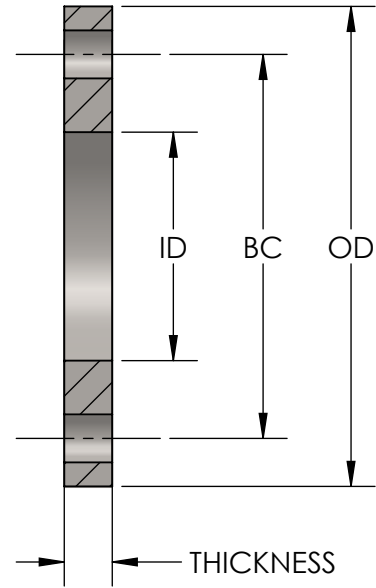
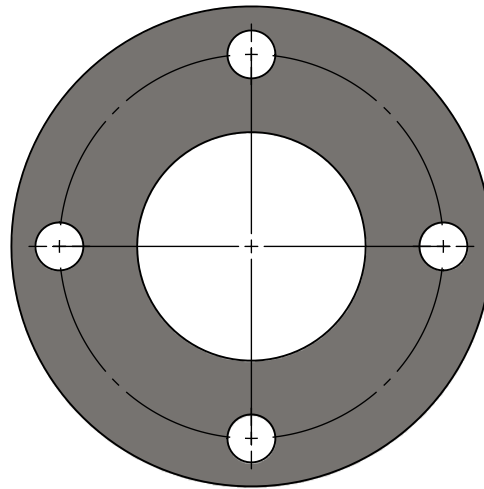

QTY	SIZE	THICKNESS	ID	OD	BC	BOLT HOLES		WEIGHT (LBS)
						NUMBER	DIAMETER	
	1"	5/8"	1.36"	4-1/4"	3-1/8"	4	5/8"	2.1
	1-1/4"	5/8"	1.70"	4-5/8"	3-1/2"	4	5/8"	2.4
	1-1/2"	5/8"	1.95"	5"	3-7/8"	4	5/8"	2.8
	2"	5/8"	2.44"	6"	4-3/4"	4	3/4"	4.0
	2-1/2"	5/8"	2.94"	7"	5-1/2"	4	3/4"	5.3
	3"	5/8"	3.57"	7-1/2"	6"	4	3/4"	6.1
	4"	5/8"	4.57"	9"	7-1/2"	8	3/4"	8.0
	5"	3/4"	5.66"	10"	8-1/2"	8	7/8"	10.5
	6"	3/4"	6.72"	11"	9-1/2"	8	7/8"	11.5
	8"	1"	8.72"	13-1/2"	11-3/4"	8	7/8"	22.4
	10"	1"	10.88"	16"	14-1/4"	12	1"	26.6
	12"	1"	12.88"	19"	17"	12	1"	41.0
	14"	1"	14.14"	21"	18-3/4"	12	1-1/8"	48.0
	16"	1"	16.16"	23-1/2"	21-1/4"	16	1-1/8"	61.3
	18"	1-1/16"	18.18"	25"	22-3/4"	16	1-1/4"	63.3

CUSTOMER: _____

PROJECT: _____

ENGINEER: _____

REV.	DATE
	
2323 W. HUBBARD ST. CHICAGO, IL 60612 TEL: 312-738-3800 FAX: 312-738-0415 WWW.METRAFLEX.COM	
150# CARBON STEEL SLIP-ON FLANGE	
DRAWN BY: DKISH	DATE: 6/7/2018
APPROVED: JR	DATE: 6/7/2018
SCALE: NTS	DRAWING NUMBER: 150-FLG