

Note: Do not use wrenches on hose or braid collar.

Qty	Model	Size I.D. (in)	A (in)	Pressure @ 70°F (PSI)	Weight (Lbs)	Project Info
	GASCT0050	1/2	16-7/8	150	0.8	
	GASCT0075	3/4	18-3/8	150	1.4	
	GASCT0100	1	19-3/8	150	1.8	
	GASCT0125	1-1/4	19-3/8	150	2.3	
	GASCT0150	1-1/2	20-1/8	150	2.9	
	GASCT0200	2	20-7/8	150	3.9	
	GASCT0250	2-1/2	22-1/2	150	5.7	
	GASCT0300	3	25-5/8	150	8.1	
	GASCT0400	4	30-1/4	150	11.9	

MAX INTERMITTENT OFFSET FROM CENTERLINE: 2"
CONTACT METRAFLEX FOR CUSTOM LENGTHS.

NSF 372 - LEAD FREE

The wetted surface of this product contacted by consumable water contains less than one quarter of one percent (0.25%) of lead by weight. Material complies with state codes and standards, where applicable, requiring reduced lead content.

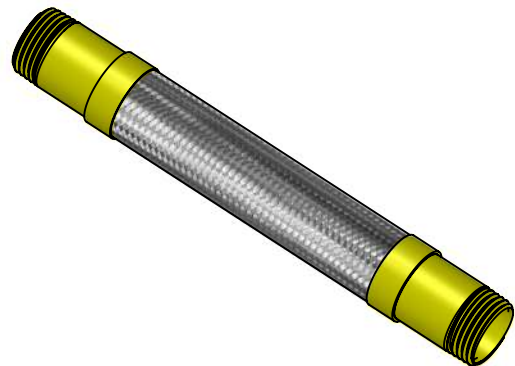

CUSTOMER: _____

PROJECT: _____

ENGINEER: _____

REV. 4	OFFSET UPDATED	DATE 10/26/2016
		2323 W. HUBBARD ST. CHICAGO, IL 60612 TEL: 312-738-3800 FAX: 312-738-0415 WWW.METRAFLEX.COM
<h2>MODEL GASCT</h2> <h3>FLEXIBLE CONNECTOR FOR GAS SERVICE</h3>		
DRAWN BY: DKISH		DATE: 1/10/2014
APPROVED: JC		DATE: 1/10/2014
SCALE: N/A	DRAWING NUMBER: GASCT-4	

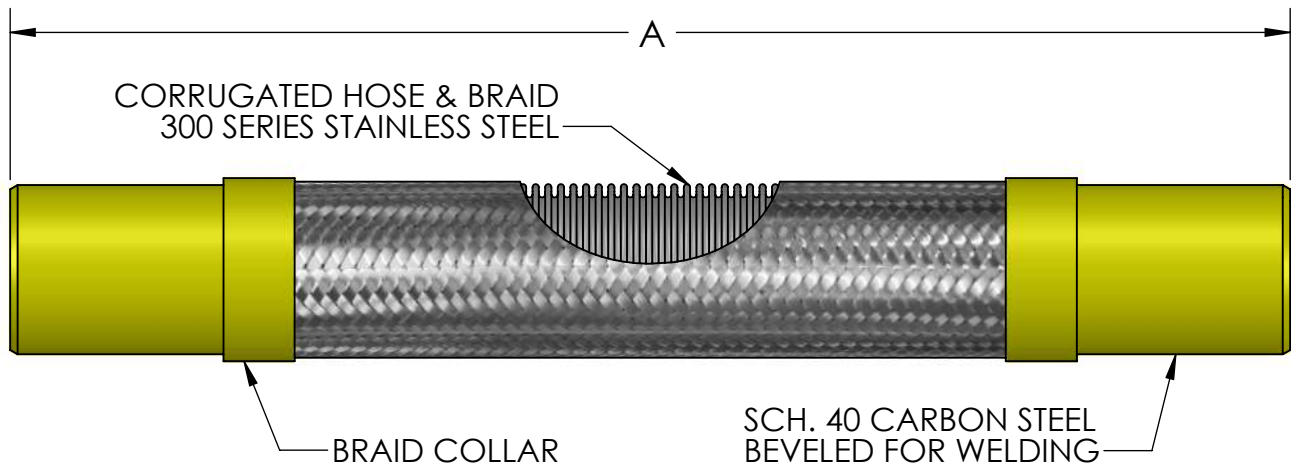

Note: Do not use wrenches on hose or braid collar.

Qty	Model	Size I.D. (in)	A (in)	Pressure @ 70°F (PSI)	Weight (Lbs)	Project Info
	GASCW0050	1/2	16-7/8	150	0.8	
	GASCW0075	3/4	18-3/8	150	1.4	
	GASCW0100	1	19-3/8	150	1.8	
	GASCW0125	1-1/4	19-3/8	150	2.3	
	GASCW0150	1-1/2	20-1/8	150	2.9	
	GASCW0200	2	20-7/8	150	3.9	
	GASCW0250	2-1/2	22-1/2	150	5.7	
	GASCW0300	3	25-5/8	150	8.1	
	GASCW0400	4	30-1/4	150	11.9	

MAX INTERMITTENT OFFSET FROM CENTERLINE: 2"
CONTACT METRAFLEX FOR CUSTOM LENGTHS.

NSF 372 - LEAD FREE

The wetted surface of this product contacted by consumable water contains less than one quarter of one percent (0.25%) of lead by weight. Material complies with state codes and standards, where applicable, requiring reduced lead content.

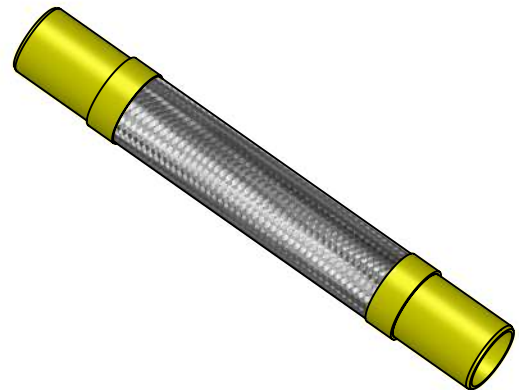

CUSTOMER: _____

PROJECT: _____

ENGINEER: _____

REV. 4	OFFSET UPDATED	DATE 10/26/2016
		2323 W. HUBBARD ST. CHICAGO, IL 60612 TEL: 312-738-3800 FAX: 312-738-0415 WWW.METRAFLEX.COM
MODEL GASCW FLEXIBLE CONNECTOR FOR GAS SERVICE		
DRAWN BY: DKISH		DATE: 1/10/2014
APPROVED: JC		DATE: 1/10/2014
SCALE: N/A	DRAWING NUMBER: GASCW-4	