

METRAFLEX METRAGATOR
150 PSI, 6" AXIAL COMPRESSION, WELD ENDS
EXTERNALLY PRESSURIZED EXPANSION JOINT

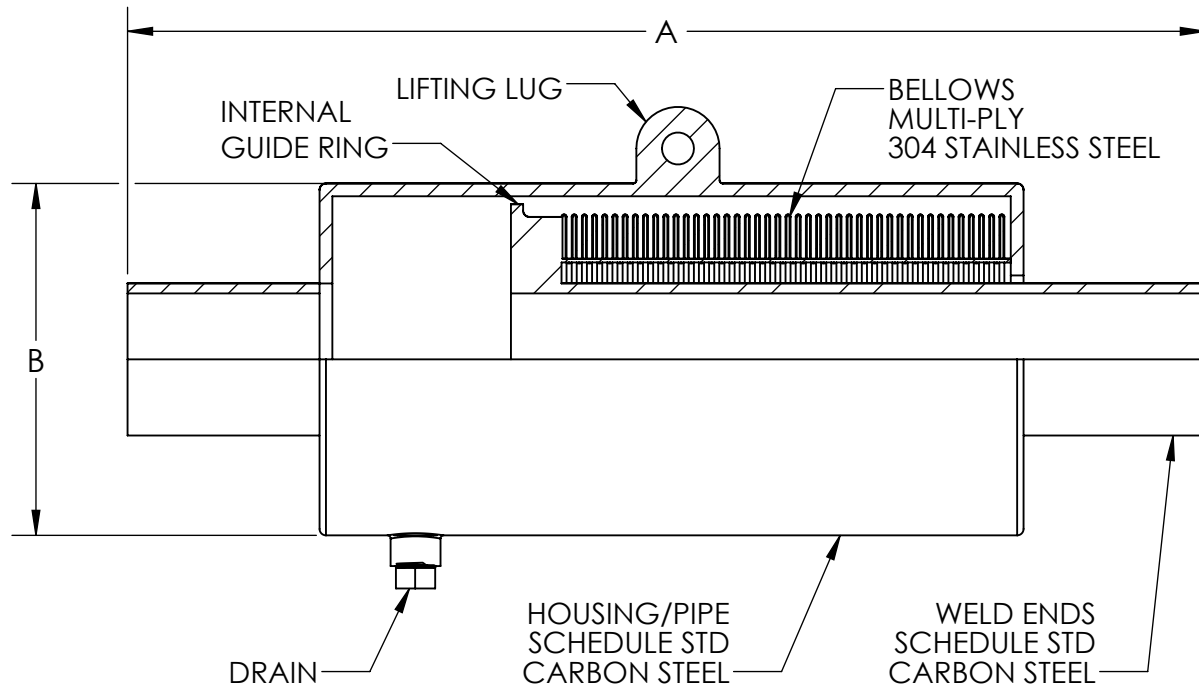

THE EXPANSION JOINT IS DESIGNED FOR AXIAL MOVEMENT ONLY. PIPE MUST BE PROPERLY GUIDED AND ANCHORED PER THE RECOMMENDATIONS OF THE EXPANSION JOINT MANUFACTURERS ASSOCIATION.

QTY	PART NUMBER	PIPE SIZE		A (in)	B (in)	EFF. AREA (in ²)	SPRING RATE (lb/in)	NOTES
		NPS	MM					
	GAT06SW0200	2	50	31	5.5	13.2	115.0	
	GAT06SW0250	2.5	65	31.25	5.5	13.2	115.0	
	GAT06SW0300	3	80	29.5	6.5	20.8	235.0	
	GAT06SW0400	4	100	30.75	8.5	36.0	143.0	
	GAT06SW0500	5	130	30.75	10.75	46.4	166.0	
	GAT06SW0600	6	150	31.5	12.75	58.9	189.0	
	GAT06SW0800	8	200	33.75	14	88.8	234.0	
	GAT06SW1000	10	250	33	16	124.6	280.0	
	GAT06SW1200	12	300	32.25	18	166.6	326.0	

DESIGN DATA

TEMPERATURE: 700°F (370°C)
 PRESSURE: 150 PSI (1034 KPa)
 TEST PRESSURE: 225 PSI (1551 KPa)
 AXIAL MOVEMENT: 6" COMPRESSION (150 mm)

MILITARY SPECS:

CONFORMS TO MIL-E-17813H AND ASTM-F-2934

NOTE: ANCHOR LOAD =
 (MAX PSI X EFFECTIVE AREA) +
 (SPRING RATE X MOVEMENT)

CUSTOMER: _____

PROJECT: _____

ENGINEER: _____

REV.	DATE
	
2323 W. HUBBARD ST. CHICAGO, IL 60612 TEL: 312-738-3800 FAX: 312-738-0415 WWW.METRAFLEX.COM	
METRAFLEX METRAGATOR, 150 PSI, 6" AXIAL COMPRESSION, WELD ENDS	
DRAWN BY: DKISH	DATE: 6/1/2015
APPROVED: ZB	DATE: 6/2/2015
SCALE: N/A	DRAWING NUMBER: GAT06SW