

**150# CARBON STEEL  
SLIP-ON PLATE FLANGES**

MATERIAL: ASTM A36

ALL SURFACES TO BE MACHINED (ID, OD, AND BOTH FACES) AND COATED WITH A RUST PROHIBITIVE.

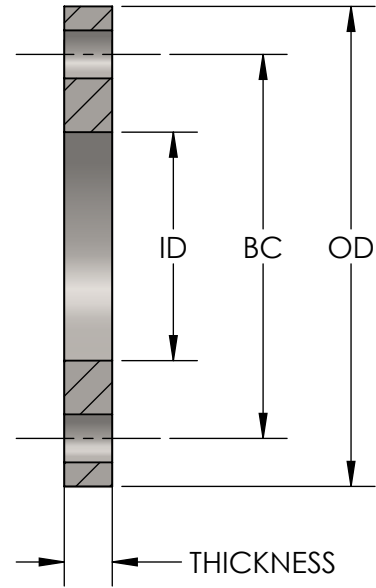
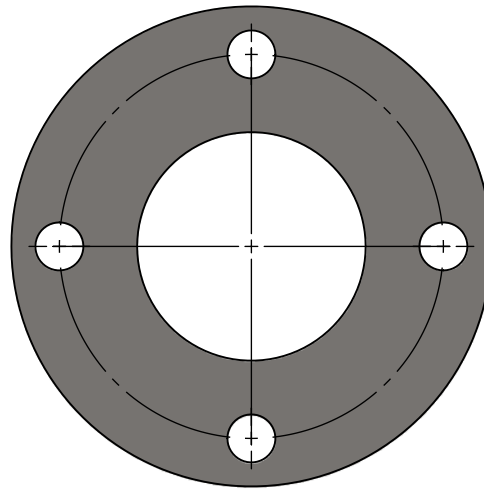

QTY	SIZE	THICKNESS	ID	OD	BC	BOLT HOLES		WEIGHT (LBS)
						NUMBER	DIAMETER	
	1"	5/8"	1.36"	4-1/4"	3-1/8"	4	5/8"	2.1
	1-1/4"	5/8"	1.70"	4-5/8"	3-1/2"	4	5/8"	2.4
	1-1/2"	5/8"	1.95"	5"	3-7/8"	4	5/8"	2.8
	2"	5/8"	2.44"	6"	4-3/4"	4	3/4"	4.0
	2-1/2"	5/8"	2.94"	7"	5-1/2"	4	3/4"	5.3
	3"	5/8"	3.57"	7-1/2"	6"	4	3/4"	6.1
	4"	5/8"	4.57"	9"	7-1/2"	8	3/4"	8.0
	5"	3/4"	5.66"	10"	8-1/2"	8	7/8"	10.5
	6"	3/4"	6.72"	11"	9-1/2"	8	7/8"	11.5
	8"	1"	8.72"	13-1/2"	11-3/4"	8	7/8"	22.4
	10"	1"	10.88"	16"	14-1/4"	12	1"	26.6
	12"	1"	12.88"	19"	17"	12	1"	41.0
	14"	1"	14.14"	21"	18-3/4"	12	1-1/8"	48.0
	16"	1"	16.16"	23-1/2"	21-1/4"	16	1-1/8"	61.3
	18"	1-1/16"	18.18"	25"	22-3/4"	16	1-1/4"	63.3

CUSTOMER: \_\_\_\_\_

PROJECT: \_\_\_\_\_

ENGINEER: \_\_\_\_\_

REV.	DATE
	
2323 W. HUBBARD ST. CHICAGO, IL 60612 TEL: 312-738-3800 FAX: 312-738-0415 WWW.METRAFLEX.COM	
<b>150# CARBON STEEL SLIP-ON FLANGE</b>	
DRAWN BY: <b>DKISH</b>	DATE: <b>6/7/2018</b>
APPROVED: <b>JR</b>	DATE: <b>6/7/2018</b>
SCALE: <b>NTS</b>	DRAWING NUMBER: <b>150-FLG</b>

# 150# STAINLESS STEEL SLIP-ON PLATE FLANGES

MATERIAL: 304 OR 316 STAINLESS

ALL SURFACES TO BE MACHINED (ID, OD, AND BOTH FACES) AND COATED WITH A RUST PROHIBITIVE.

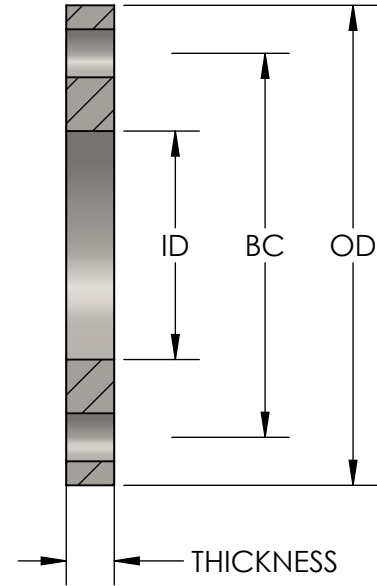
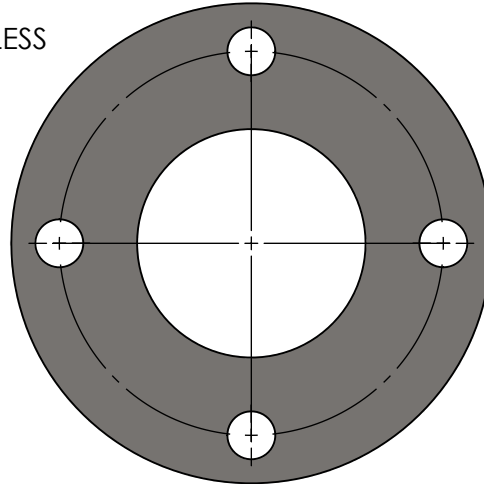

QTY	SIZE	THICKNESS	ID	OD	BC	BOLT HOLES		WEIGHT (LBS)
						NUMBER	DIAMETER	
	1"	1/2"	1.36"	4-1/4"	3-1/8"	4	5/8"	1.7
	1-1/4"	1/2"	1.70"	4-5/8"	3-1/2"	4	5/8"	2.0
	1-1/2"	1/2"	1.95"	5"	3-7/8"	4	5/8"	2.3
	2"	1/2"	2.44"	6"	4-3/4"	4	3/4"	3.3
	2-1/2"	1/2"	2.94"	7"	5-1/2"	4	3/4"	4.5
	3"	1/2"	3.57"	7-1/2"	6"	4	3/4"	4.9
	4"	1/2"	4.57"	9"	7-1/2"	8	3/4"	6.5
	5"	1/2"	5.66"	10"	8-1/2"	8	7/8"	7.3
	6"	1/2"	6.72"	11"	9-1/2"	8	7/8"	8.2
	8"	1/2"	8.72"	13-1/2"	11-3/4"	8	7/8"	11.8
	10"	5/8"	10.88"	16"	14-1/4"	12	1"	18.4
	12"	5/8"	12.88"	19"	17"	12	1"	26.8
	14"	5/8"	14.14"	21"	18-3/4"	12	1-1/8"	33.1
	16"	5/8"	16.16"	23-1/2"	21-1/4"	16	1-1/8"	47.5
	18"	3/4"	18.18"	25"	22-3/4"	16	1-1/4"	60.0

\*UNLESS OTHERWISE SPECIFIED, THE MANUFACTURER MAY SUPPLY EITHER SPIRAL OR CONCENTRIC GROOVES FOR SERRATIONS ON BOTH FLANGE FACES. THE SPIRAL MACHINING OPERATION IS COMMONLY ACCOMPLISHED WITH THE CUTTING TOOL HAVING 0.06" (1.6MM) OR LARGER TIP RADIUS. FINISH ON FLANGE FACES IS TO CONFORM TO MSS SP-6 STANDARD.

CUSTOMER: \_\_\_\_\_

PROJECT: \_\_\_\_\_

ENGINEER: \_\_\_\_\_

REV.	DATE
	
2323 W. HUBBARD ST. CHICAGO, IL 60612 TEL: 312-738-3800 FAX: 312-738-0415 WWW.METRAFLEX.COM	
<b>150# STAINLESS STEEL SLIP-ON FLANGE</b>	
DRAWN BY: <b>DKISH</b>	DATE: <b>6/7/2018</b>
APPROVED: <b>JR</b>	DATE: <b>6/7/2018</b>
SCALE: <b>NTS</b>	DRAWING NUMBER: <b>150-FLG-SS</b>