

**MODEL RSSC  
REDUCING FLANGED FLEXIBLE PUMP CONNECTOR**

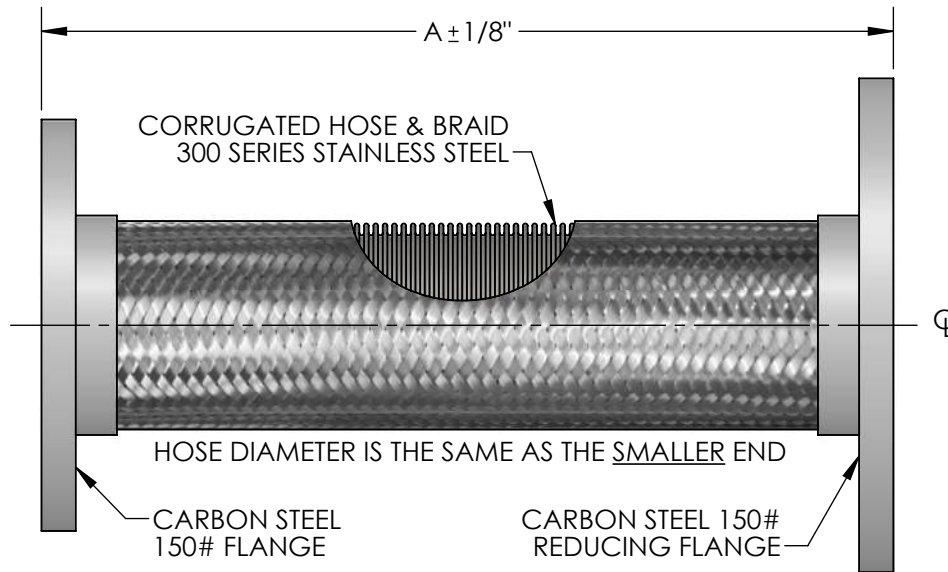

QTY	PART NUMBER	PIPE SIZE		A	PRESSURE RATING (PSI)*	WEIGHT (LBS)	PROJECT INFORMATION
		SMALLER	LARGER				
	RSSC2503	2-1/2"	3"	9"	387	12	
	RSSC2504	2-1/2"	4"	9"	387	14	
	RSSC0304	3"	4"	9"	316	16	
	RSSC0305	3"	5"	9"	316	22	
	RSSC0405	4"	5"	9"	232	25	
	RSSC0406	4"	6"	9"	232	30	
	RSSC0506	5"	6"	11"	191	35	
	RSSC0508	5"	8"	11"	191	58	
	RSSC0608	6"	8"	11"	165	61	
	RSSC0610	6"	10"	11"	165	80	
	RSSC0810	8"	10"	12"	234	85	
	RSSC0812	8"	12"	12"	234	105	
	RSSC1012	10"	12"	13"	230	132	

\*FOR SAFE WORKING PRESSURE ABOVE 70°F, MULTIPLY THE PRESSURE SHOWN AT 70°F TIMES THE CORRECTION FACTOR OF THE REQUIRED TEMPERATURE.

MAX INTERMITTENT OFFSET FROM CENTERLINE 1/8"  
MAX PERMANENT OFFSET FROM CENTERLINE 3/8"

TEMPERATURE (°F)	FACTOR
70	1.0
200	.91
300	.85
400	.78
500	.77
600	.76

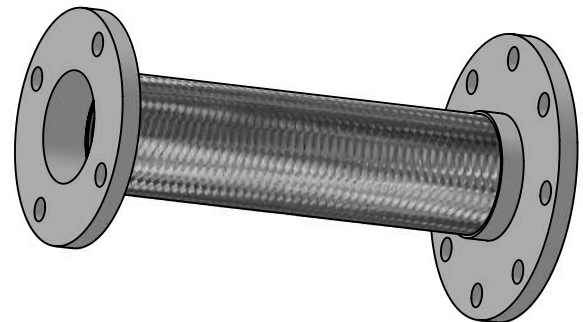

**NSF 372 - LEAD FREE**

The wetted surface of this product contacted by consumable water contains less than one quarter of one percent (0.25%) of lead by weight. Material complies with state codes and standards, where applicable, requiring reduced lead content.

CUSTOMER: \_\_\_\_\_

PROJECT: \_\_\_\_\_

ENGINEER: \_\_\_\_\_

REV.	1	TEMP FACTOR UPDATED	DATE 12/28/2016
		2323 W. HUBBARD ST. CHICAGO, IL 60612 TEL: 312-738-3800 FAX: 312-738-0415 WWW.METRAFLEX.COM	
		<b>MODEL RSSC</b> REDUCING FLEXIBLE PUMP CONNECTOR	
DRAWN BY: <b>DKISH</b>		DATE: <b>1/10/2014</b>	
APPROVED: <b>JC</b>		DATE: <b>1/10/2014</b>	
SCALE: N/A		DRAWING NUMBER: <b>RSSC-1</b>	