

# MODEL SDFS90GF

## SUCTION DIFFUSER FLEX WITH GROOVE x 150# PLATE FLANGE AND A SR ELBOW

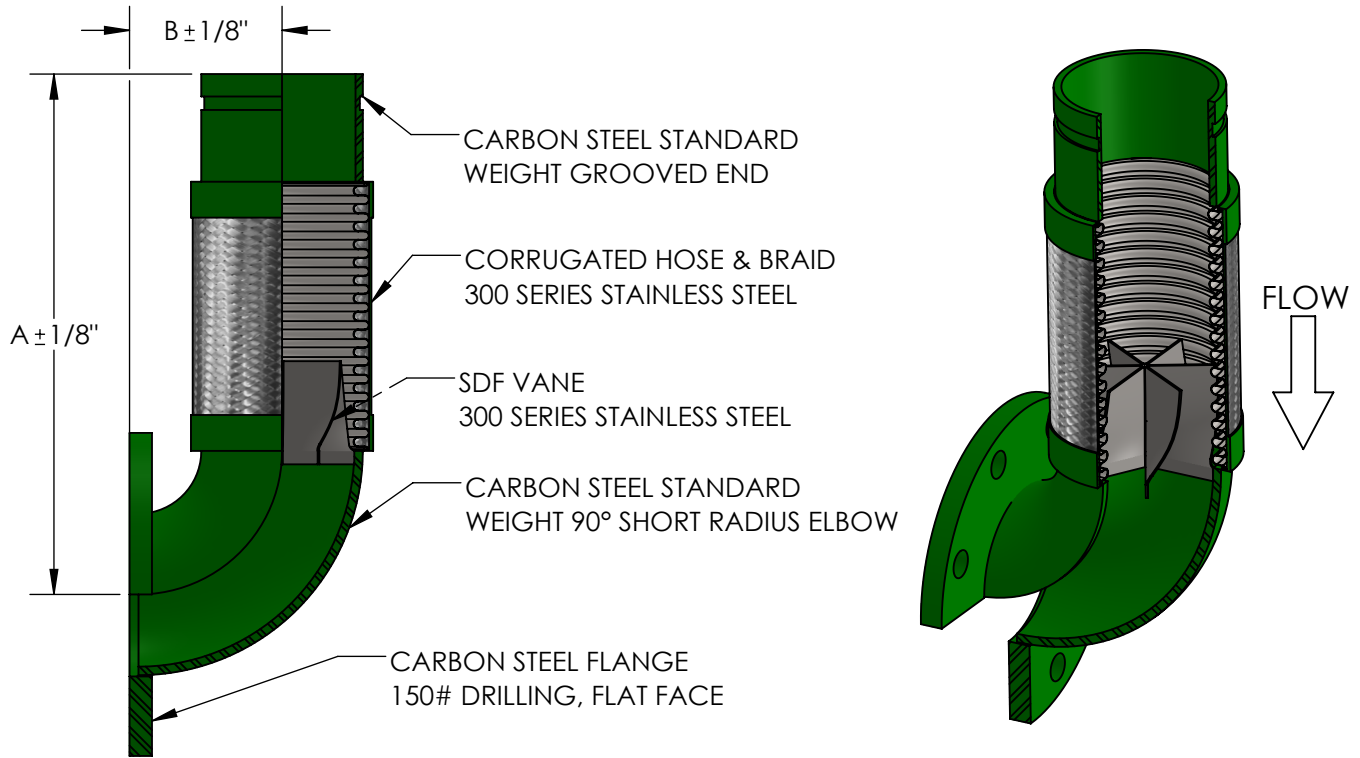

QTY	PART NUMBER	PIPE SIZE		A	B	PRESSURE RATING (PSI)*	WEIGHT (LBS)	PROJECT INFORMATION
		INCH	MM					
	SDFS90GF0200	2"	50	13-1/4"	2-1/4"	516	12	
	SDFS90GF0250	2-1/2"	65	13-3/4"	2-3/4"	387	18	
	SDFS90GF0300	3"	80	14-1/4"	3-1/4"	316	20	
	SDFS90GF0400	4"	100	15-1/4"	4-1/4"	232	28	
	SDFS90GF0500	5"	125	18-1/4"	5-1/4"	191	38	
	SDFS90GF0600	6"	150	19-1/4"	6-1/4"	165	49	
	SDFS90GF0800	8"	200	22-3/4"	8-1/4"	234	89	
	SDFS90GF1000	10"	250	25-3/4"	10-1/4"	230	136	
	SDFS90GF1200	12"	300	28-3/4"	12-1/4"	161	190	
	SDFS90GF1400	14"	350	30-3/4"	14-1/4"	150	224	

\*FOR SAFE WORKING PRESSURE ABOVE 70°F, MULTIPLY THE PRESSURE SHOWN AT 70°F TIMES THE CORRECTION FACTOR OF THE REQUIRED TEMPERATURE.

MAX INTERMITTENT OFFSET FROM CENTERLINE 1/8"  
MAX PERMANENT OFFSET FROM CENTERLINE 3/8"

TEMPERATURE (°F)	FACTOR
70	1.0
200	.91
300	.85
400	.78
500	.77
600	.76

### NSF 372 - LEAD FREE

The wetted surface of this product contacted by consumable water contains less than one quarter of one percent (0.25%) of lead by weight. Material complies with state codes and standards, where applicable, requiring reduced lead content. Not suitable for potable water systems due to materials of construction.

CUSTOMER: \_\_\_\_\_

PROJECT: \_\_\_\_\_

ENGINEER: \_\_\_\_\_

REV.	1	TEMP FACTOR UPDATED	DATE 1/4/2017
		2323 W. HUBBARD ST. CHICAGO, IL 60612 TEL: 312-738-3800 FAX: 312-738-0415 WWW.METRAFLEX.COM	
<h2>MODEL SDFS90GF</h2> <p>SDF, 150# PLATE FLANGE x GROOVE, SR ELBOW</p>			
DRAWN BY: <b>DKISH</b>		DATE: <b>11/22/2013</b>	
APPROVED: <b>JC</b>		DATE: <b>11/22/2013</b>	
SCALE: N/A	DRAWING NUMBER: SDFS90GF-1		