

**MODEL SLPC
FLANGED FLEXIBLE PUMP CONNECTOR**

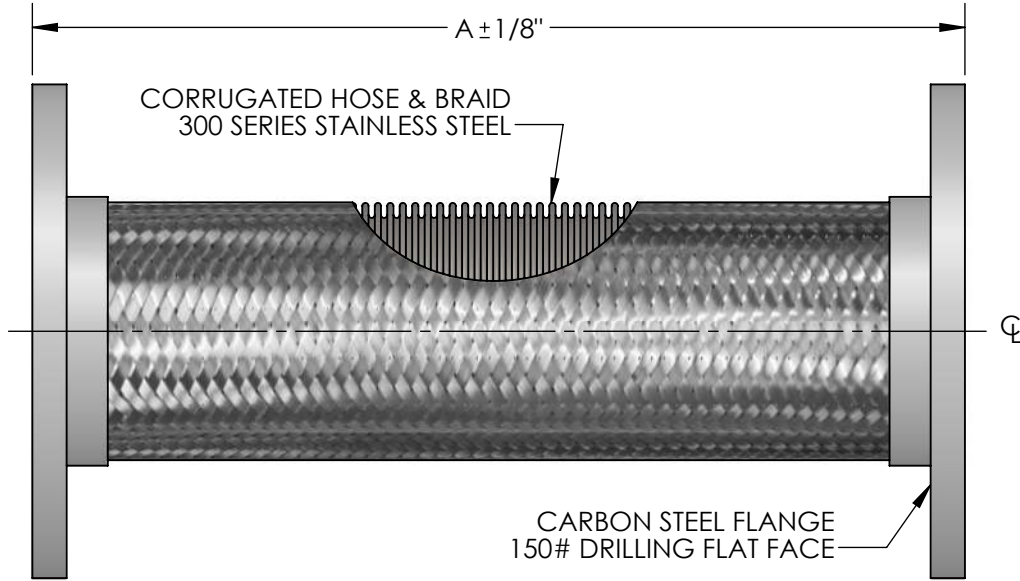

QTY	PART NUMBER	PIPE SIZE		A	PRESSURE RATING (PSI)*	WEIGHT (LBS)	PROJECT INFORMATION
		INCH	MM				
	SLPC0250	2-1/2"	65	10-1/4"	387	13	
	SLPC0300	3"	80	10-5/8"	316	14	
	SLPC0400	4"	100	11-3/4"	232	19	
	SLPC0500	5"	125	13-5/8"	191	27	
	SLPC0600	6"	150	14-1/8"	165	30	
	SLPC0800	8"	200	15-3/8"	234	62	
	SLPC1000	10"	250	17-3/4"	230	68	
	SLPC1200	12"	300	18-3/8"	161	106	
	SLPC1400	14"	350	20"	150	118	

*FOR SAFE WORKING PRESSURE ABOVE 70°F, MULTIPLY THE PRESSURE SHOWN AT 70°F TIMES THE CORRECTION FACTOR OF THE REQUIRED TEMPERATURE.

MAX INTERMITTENT OFFSET FROM CENTERLINE 3/8"
MAX PERMANENT OFFSET FROM CENTERLINE 3/4"

TEMPERATURE (°F)	FACTOR
70	1.0
200	.91
300	.85
400	.78
500	.77
600	.76

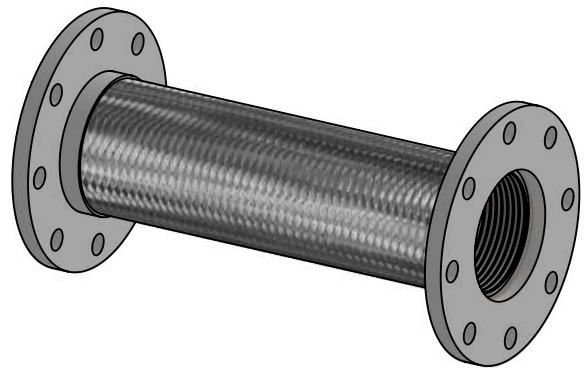

NSF 372 - LEAD FREE

The wetted surface of this product contacted by consumable water contains less than one quarter of one percent (0.25%) of lead by weight. Material complies with state codes and standards, where applicable, requiring reduced lead content.

CUSTOMER: _____

PROJECT: _____

ENGINEER: _____

REV.	1	TEMP FACTOR UPDATED	DATE 12/28/2016
		2323 W. HUBBARD ST. CHICAGO, IL 60612 TEL: 312-738-3800 FAX: 312-738-0415 WWW.METRAFLEX.COM	
MODEL SLPC FLANGED FLEXIBLE PUMP CONNECTOR			
DRAWN BY: DKISH		DATE: 1/10/2014	
APPROVED: JC		DATE: 1/10/2014	
SCALE: N/A	DRAWING NUMBER: SLPC-1		