

STRUCTURAL I-BEAM ANCHORS

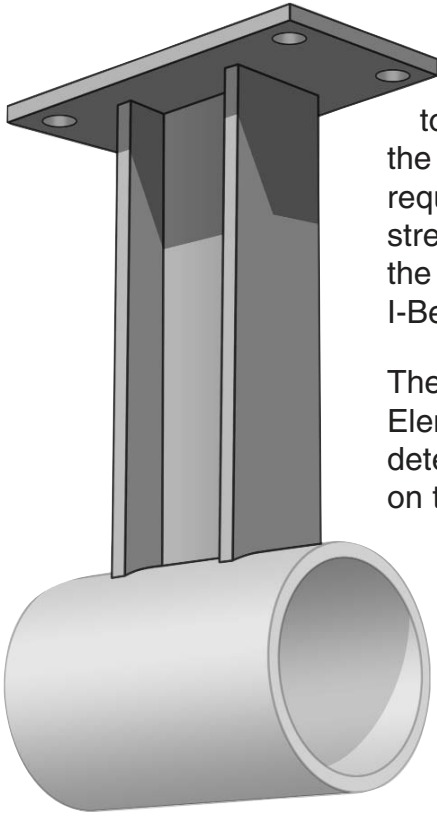

Design Analysis:

Von Mises stress was used to calculate the safety factor of the anchor with various load requirements. The highest stressed point was the base of the weld at the front edge of the I-Beam.

The Pro/MECHANICA® Finite Element Model was used to determine the high stress areas on the anchor and calculate the

safety factor. The model was constrained along the edges of the base plate to simulate the welding of the anchor to the existing structure. This method of constraint was chosen because of the unknown factors in the bolting of the anchor to different structures. All edges of the base plate were constrained in XYZ translation. The model was meshed with "P" elements, which also included the weld geometry.

MIN PIPE DIA.	ANCHOR MODEL #	MAX. ANCHOR FORCE (KIPS)				
		BASE/STRUCTURE TO CENTER OF PIPE				
		12"	18"	24"	36"	48"
2	PAI-1	1.397	0.951	0.732	0.497	0.371
2.5	PAI-2	2.338	1.545	1.149	0.76	0.565
3	PAI-3	3.211	2.15	1.617	1.08	0.812
3	PAI-4	4.256	2.945	2.293	1.586	1.229
4	PAI-5	5.143	3.404	2.535	1.678	1.249
4	PAI-6	10.183	7.089	5.596	3.919	3.072
6	PAI-7	7.467	4.887	3.6	2.357	1.733
6	PAI-8	13.388	9.371	7.366	5.137	4.015
6	PAI-9	18.846	13.178	10.341	7.189	5.629
8	PAI-10	24.545	16.444	12.393	8.388	6.385
8	PAI-11	30.912	21.165	16.289	11.135	8.558
10	PAI-12	31.101	22.319	17.928	12.745	10.153
10	PAI-13	42.936	30.298	23.979	16.823	13.245
10	PAI-14	52.225	36.957	29.319	20.595	16.236
10	PAI-15	62.308	41.328	30.838	20.453	15.261
16	PAI-16	63.399	53.456	37.304	23.703	16.802

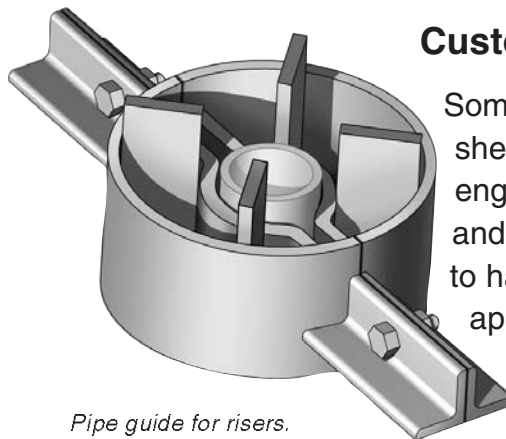
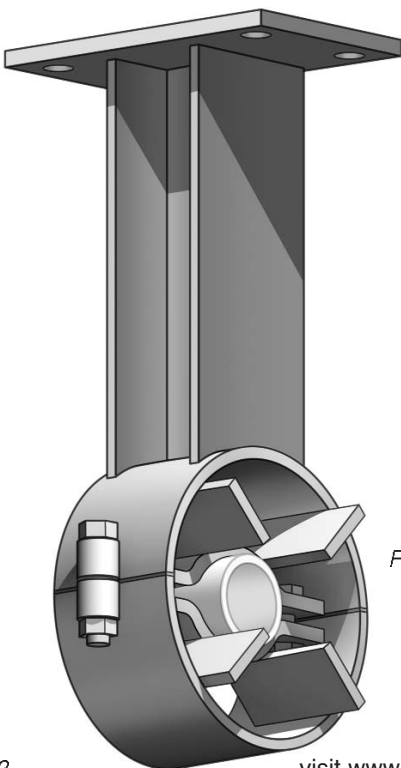

Pipe guide for risers.

Pipe guide with I-Beam.

Custom Fabricated Guides

Some applications defy off-the-shelf solutions. Metraflex engineers can help you design and engineer custom guides to handle even the most difficult applications. Contact Metraflex today for technical assistance.

