

D.W.V. METRALOOP 150# FLOATING FLANGES ± 8" MOVEMENT

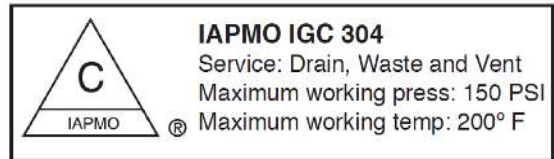
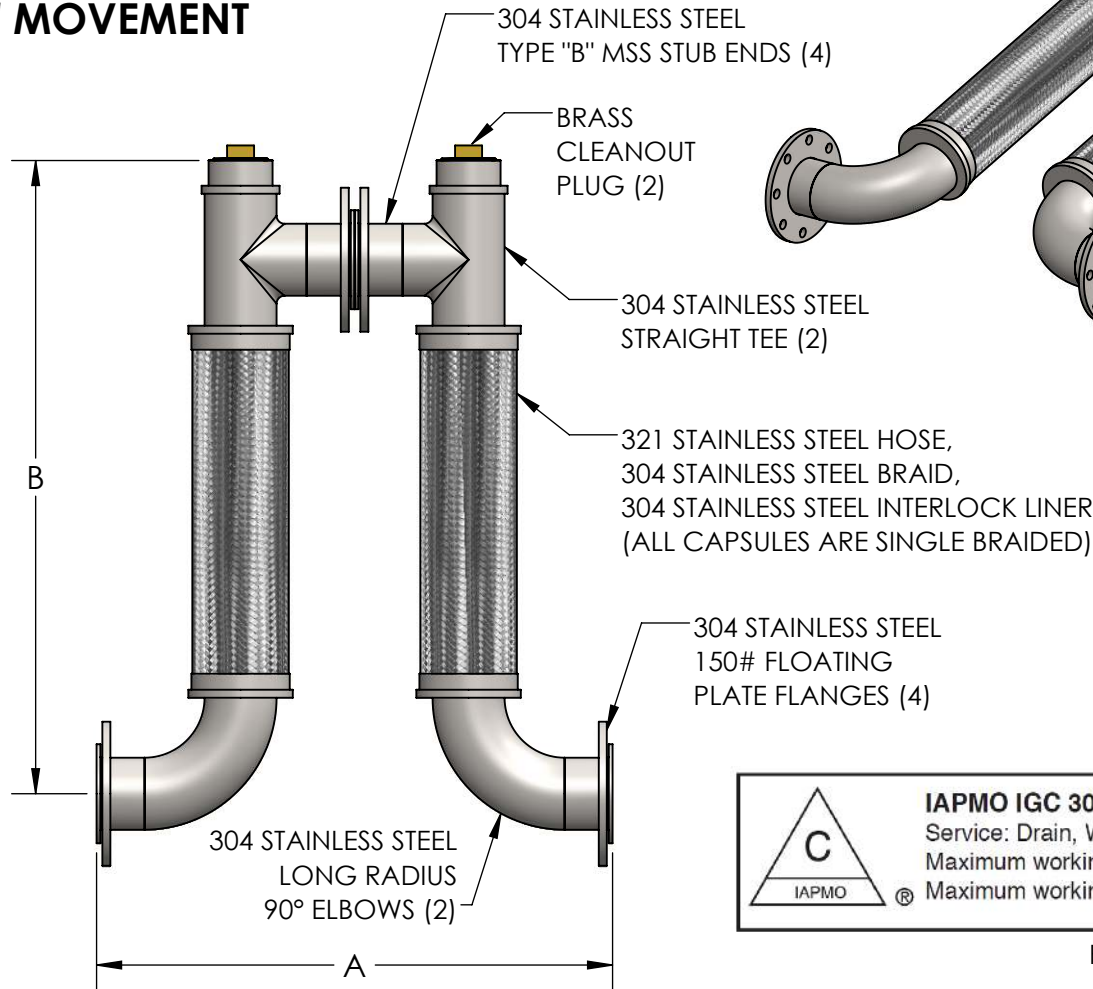

File No. C-9261

NOTE: D.W.V. METRALOOPS INSTALLED IN ANY ORIENTATION OTHER THAN HANGING DOWN MUST HAVE THE 180° RETURN SUPPORTED. (SEE INSTALLATION INSTRUCTIONS.)

CONTACT FACTORY FOR ADDITIONAL SIZES AND MOVEMENTS. ALL DIMENSIONS IN INCHES.

QTY	SIZE	MODEL	MVMT	A	B	PSI*	SPRING FORCE**	PROJECT INFO
	4"	MLFILP160400	±8"	32.25"	47"	150	375	
	5"	MLFILP160500	±8"	36.75"	52"	150	405	

*Working temperature listed is the rating at 70°F. Contact factory for other pressure ratings at other temperatures.

**Spring force: The total force (Lbs) required to move the Metraloop its full rated movement for 150 PSI @ 70°F.

CUSTOMER: _____

PROJECT: _____

ENGINEER: _____

REV.	DATE
2323 W. HUBBARD ST. CHICAGO, IL 60612 TEL: 312-738-3800 FAX: 312-738-0415 WWW.METRAFLEX.COM	
D.W.V. METRALOOP, FLOATING FLANGES, ±8" MOVEMENT	
DRAWN BY: DKISH	DATE: 5/29/2015
APPROVED: JC	DATE: 5/29/2015
SCALE: N/A	DRAWING NUMBER: MLFILP16-4AND5

D.W.V. METRALOOP
150# FLOATING FLANGES
± 8" MOVEMENT

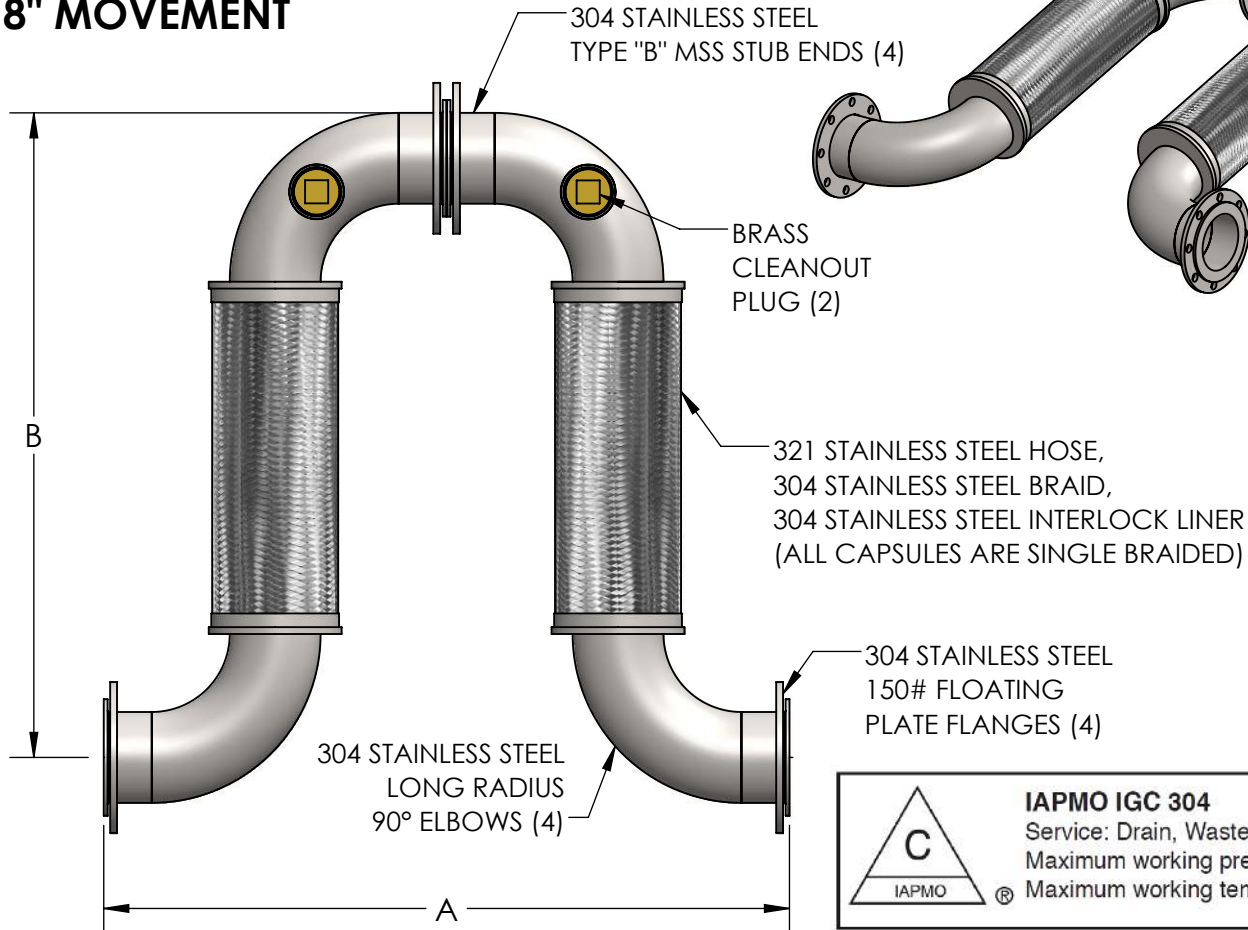

	IAPMO IGC 304
	Service: Drain, Waste and Vent Maximum working press: 150 PSI Maximum working temp: 200° F

File No. C-9261

NOTE: D.W.V. METRALOOPS INSTALLED IN ANY ORIENTATION OTHER THAN HANGING DOWN MUST HAVE THE 180° RETURN SUPPORTED. (SEE INSTALLATION INSTRUCTIONS.)

CONTACT FACTORY FOR ADDITIONAL SIZES AND MOVEMENTS. ALL DIMENSIONS IN INCHES.

QTY	SIZE	MODEL	MVMT	A	B	PSI*	SPRING FORCE**	PROJECT INFO
	6"	MLFILP160600	±8"	50"	56"	150	520	
	8"	MLFILP160800	±8"	64"	67"	150	600	
	10"	MLFILP161000	±8"	80"	77"	150	800	
	12"	MLFILP161200	±8"	96"	86"	150	1400	

*Working temperature listed is the rating at 70°F. Contact factory for other pressure ratings at other temperatures.

**Spring force: The total force (Lbs) required to move the Metraloop its full rated movement for 150 PSI @ 70°F.

CUSTOMER: _____

PROJECT: _____

ENGINEER: _____

REV.	DATE
2323 W. HUBBARD ST. CHICAGO, IL 60612 TEL: 312-738-3800 FAX: 312-738-0415 WWW.METRAFLEX.COM	
D.W.V. METRALOOP, FLOATING FLANGES, ± 8" MOVEMENT	
DRAWN BY: DKISH	DATE: 5/29/2015
APPROVED: JC	DATE: 5/29/2015
SCALE: N/A	DRAWING NUMBER: MLFILP16-6TO12