

MODEL PA ANCHOR CLAMP
LIGHT WEIGHT ANCHOR FOR "NO THRUST" EXPANSION JOINTS

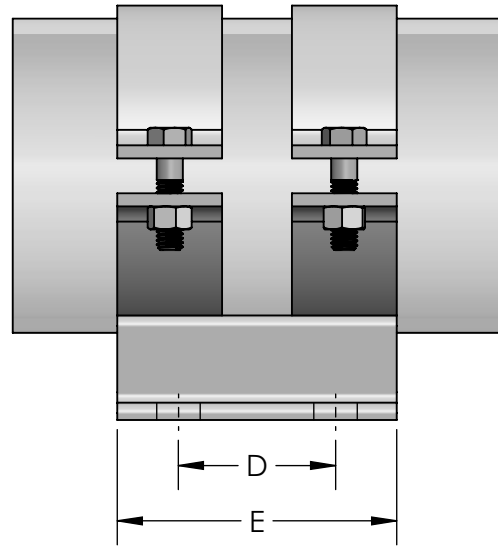

QTY	PART NUMBER	PIPE SIZE		A (in)	B (in)	C (in)	D (in)	E (in)	BOLT HOLE	WEIGHT (lbs)	NOTES
		NPS	MM								
	PA0075	0.75	20	2.125	3.375	2.75	2.75	4	0.625	3	
	PA0100	1	25	2.125	3.375	2.875	2.75	4	0.625	3	
	PA0125	1.25	32	2.375	3.375	2.875	2.75	4	0.625	3	
	PA0150	1.5	40	2.5	3.375	3.875	2.75	4	0.625	4	
	PA0200	2	50	2.75	3.375	3.875	2.75	4	0.625	4	
	PA0250	2.5	65	3	3.375	4.875	2.75	4	0.625	4	
	PA0300	3	82	3.25	4.125	4.875	2.75	4	0.625	4	
	PA0400	4	100	3.5	5.125	6.625	2.75	4	0.625	5	
	PA0500	5	130	4.5	5.875	8.375	4	6	0.75	7	
	PA0600	6	150	5	6.25	8.375	4	6	0.75	8	
	PA0800	8	200	6	6.75	10.875	4	6	0.75	9	
	PA1000	10	250	7	7.75	12.625	4	6	0.75	14	
	PA1200	12	300	8	8.125	14.75	4	6	0.75	16	

MATERIAL: CARBON STEEL
 FINISH: ONE COAT OF PAINT

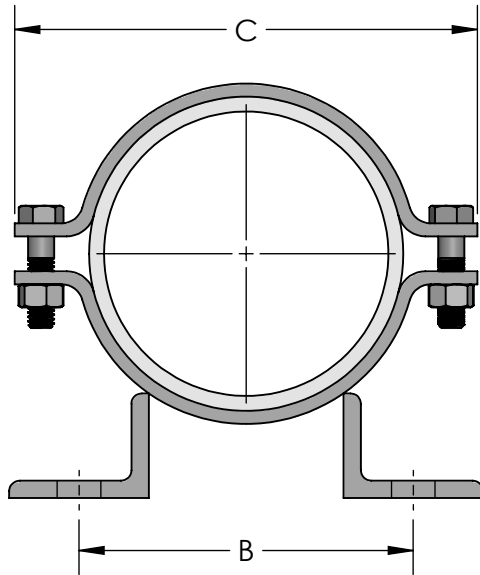

FEET CAN BE BOLTED OR
 WELDED TO STRUCTURE

CUSTOMER: _____

PROJECT: _____

ENGINEER: _____

REV. 1	EDIT WELD ANNOTATIONS	DATE: 05/21/2019
		2323 W. HUBBARD ST. CHICAGO, IL 60612 TEL: 312-738-3800 FAX: 312-738-0415 WWW.METRAFLEX.COM
MODEL PA ANCHOR CLAMP		
DRAWN BY: DKISH		DATE: 12/2/2016
APPROVED: EB		DATE: 12/2/2016
SCALE: N/A	DRAWING NUMBER: PACLAMP-1	