

MODEL PAPI PRE-INSULATED ANCHOR

ANCHOR HARDWARE

AVAILABLE MATERIALS: CARBON STEEL OR STAINLESS STEEL
POWDER-COATED FINISH (CARBON STEEL ONLY 2 MIL)

INSULATION INSERT

360° ASBESTOS-FREE XONOLITE CALCIUM SILICATE -
900 PSI COMPRESSIVE STRENGTH (10" AND 12" - 1600 PSI)
K-FACTOR: .66 @ 400°F (10" AND 12" - .70 @ 400°F)
MEETS ASTM C-533, C-585, C-795, E-72, AND E-84.
FLAME SPREAD -0-, SMOKE DEVELOPED -0-
ALL UNITS INCLUDE A VAPOR BARRIER JACKET MEETING ASTM D-744
AND PROTECTION SHIELD OF GALVANIZED OR STAINLESS STEEL

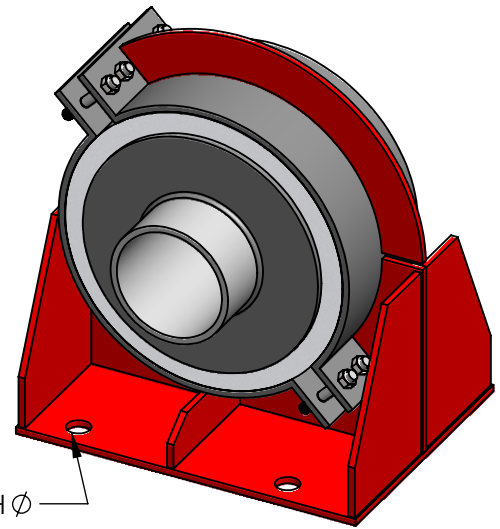

H Ø

COMPLETELY ASSEMBLED. READY TO BE WELDED TO PIPE AND BOLTED OR WELDED TO STRUCTURE. DUAL PLATE DESIGN MEANS THE PAPI IS BI-DIRECTIONAL.

HIGH ANCHOR LOADS. NO METAL TO METAL CONTACT. PRE-INSULATED ANCHORS DELIVER MAXIMUM INSULATION EFFECTIVENESS AND ENERGY SAVINGS. UNIQUE DESIGN AND HIGH COMPRESSIVE STRENGTH INSULATION ALLOWS THIS ANCHOR TO SUPPORT WORKING LOADS UP TO 30,500 LBS AND TEST LOADS OF UP TO 45,750 LBS.

MAXIMUM WORKING TEMPERATURE: 1200°F

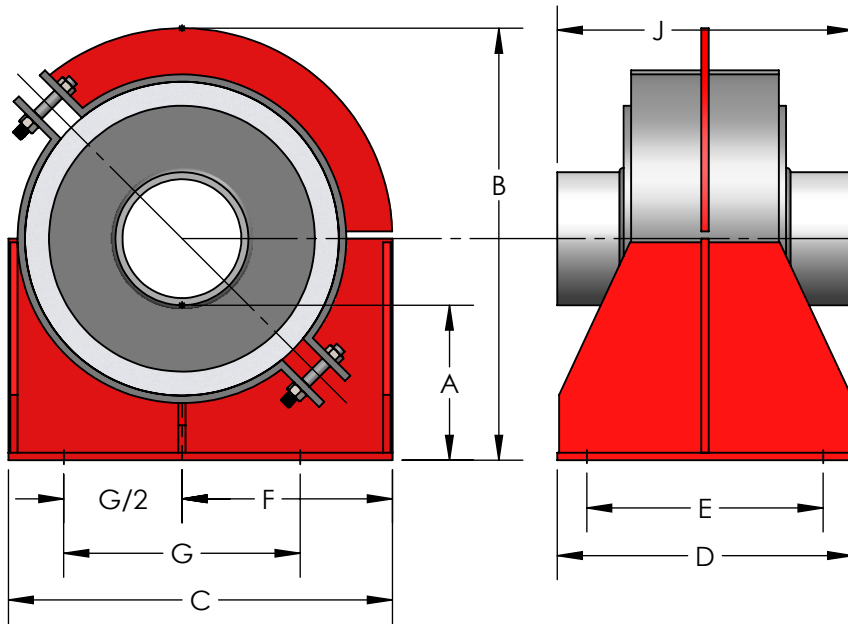

QTY	PART NUMBER	PIPE SIZE	ANCHOR DIMENSIONS									WORKING LOADS	INSULATION THICKNESS
			A	B	C	D	E	F	G	H	J		
	PAPI0150	1-1/2"	5.56"	12.13"	10.00"	8.00"	6.00"	5.63"	5.00"	0.63"	9.88"	2,200 LBS	2"
	PAPI0200	2"	5.31"	12.13"	10.00"	8.00"	6.00"	5.63"	5.00"	0.63"	9.88"	2,200 LBS	2"
	PAPI0250	2-1/2"	5.63"	13.68"	12.00"	8.00"	6.00"	6.63"	7.00"	0.63"	9.88"	5,750 LBS	2-1/2"
	PAPI0300	3"	5.31"	13.68"	12.00"	8.00"	6.00"	6.63"	7.00"	0.63"	9.88"	5,750 LBS	2-1/2"
	PAPI0400	4"	5.31"	14.63"	12.75"	10.00"	8.00"	7.06"	8.00"	0.88"	10.88"	7,150 LBS	2-1/2"
	PAPI0500	5"	5.31"	15.75"	14.00"	10.00"	8.00"	7.69"	9.00"	0.88"	10.88"	9,100 LBS	2-1/2"
	PAPI0600	6"	5.38"	17.38"	16.00"	12.00"	10.00"	8.69"	11.00"	0.88"	11.81"	12,800 LBS	3"
	PAPI0800	8"	6.81"	21"	18.75"	12.00"	10.00"	10.06"	13.00"	1.13"	11.81"	17,500 LBS	3"
	PAPI1000	10"	7.00"	24.38"	22.50"	20.00"	16.00"	12.00"	15.00"	1.63"	15.75"	24,500 LBS	3"
	PAPI1200	12"	7.19"	26.50"	24.50"	22.00"	18.00"	12.94"	17.00"	1.63"	16.63"	30,500 LBS	3"

NSF 372 - LEAD FREE

The wetted surface of this product contacted by consumable water contains less than one quarter of one percent (0.25%) of lead by weight. Material complies with state codes and standards, where applicable, requiring reduced lead content.

CUSTOMER: _____

PROJECT: _____

ENGINEER: _____

2	DIM J ADDED	3/31/2022
REV. 1	BI-DIRECTIONAL INSTALL	DATE 8/9/2021

Metraflex
for pipes in motion

2323 W. HUBBARD ST.
CHICAGO, IL 60612
TEL: 312-738-3800
FAX: 312-738-0415
WWW.METRAFLEX.COM

MODEL PAPI PRE-INSULATED ANCHOR

DRAWN BY: **DKISH** DATE: **3/15/2019**

APPROVED: _____ DATE: _____

SCALE: _____ DRAWING NUMBER: _____

N/A

PAPI-2