

Size I.D. (in)	Flange Thickness (in)	Diameter "A" (in)	Diameter "B" (in)	Overall O.D. (in)	# Of Holes	Thread Size
1	5/16	4-1/4	5-1/8	6	4	1/2-12UNC
1-1/2	11/32	5	5-7/8	6-3/4	4	1/2-12UNC
2	7/16	6	6-7/8	8-1/8	4	5/8-11UNC
2-1/2	1/2	7	8-1/8	9-3/8	4	5/8-11UNC
3	1/2	7-1/2	8-3/4	10	4	5/8-11UNC
4	5/8	9	9-7/8	11-1/8	8	5/8-11UNC
5	3/4	10	11-1/2	13	8	3/4-10UNC
6	3/4	11	12-1/2	14	8	3/4-10UNC
8	15/16	13-1/2	14-3/4	16-1/4	8	3/4-10UNC
10	1	16	17-1/2	19	12	7/8-9UNC
12	1	19	20-1/2	22	12	7/8-9UNC

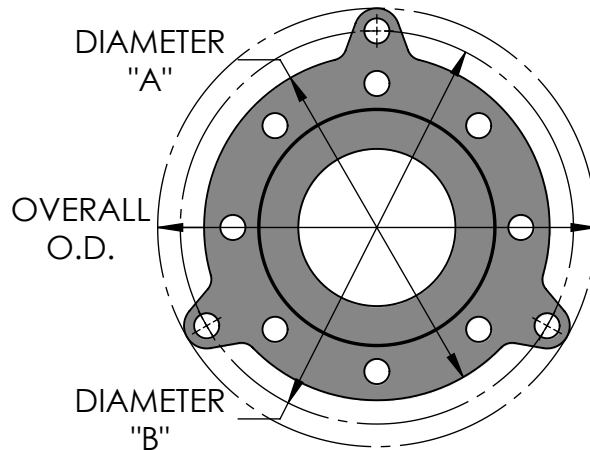

*Limit bolts are factory set to prevent extension. If extension is required, the stop nut must be adjusted.

Qty	Size I.D. (in)	F/F (in)	Maximum Axial Travel (in)	Maximum Offset (in)	MAXIMUM PRESSURE (PSI) VS TEMPERATURE				Weight (Lbs)	Vacuum Rating (in. Hg/°F)
					70°F	200°F	300°F	400°F		
	1	1-3/4	1/2	1/4	145	105	70	45	2	29.9/400
	1-1/2	2	1/2	1/4	145	105	70	45	4	29.9/400
	2	2-3/4	3/4	3/8	140	105	70	45	8	29.9/400
	2-1/2	3-3/16	3/4	3/8	140	100	65	40	11	29.9/400
	3	3-5/8	1	1/2	135	100	65	40	13	29.9/400
	4	3-5/8	1	1/2	130	95	60	35	19	29.9/400
	5	4	1	1/2	130	90	60	35	25	29.9/300
	6	4	1-1/8	9/16	125	90	60	35	30	29.9/300
	8	6	1-1/8	9/16	120	85	55	32	48	29.9/125
	10	7	1-1/8	3/8	120	85	55	30	80	19.0/212
	12	7-7/8	1-3/16	5/16	115	80	50	30	105	10.0/212

Note: Angular Deflection approx. 14 degrees. Maximum Axial Travel is based on installation with no misalignment or angular deflection. Maximum Offset is based on installation at neutral length with limit bolts in place.

Project Info	

CUSTOMER: _____

PROJECT: _____

ENGINEER: _____

REV.	DATE
2323 W. HUBBARD ST. CHICAGO, IL 60612 TEL: 312-738-3800 FAX: 312-738-0415 WWW.METRAFLEX.COM	
MODEL T2R PTFE MOLDED FLEXIBLE COUPLING	
DRAWN BY: DKISH	DATE: 8/11/2014
APPROVED: DANH	DATE: 8/11/2014
SCALE: NONE	DRAWING NUMBER: T2R-1