

**MODEL RMF  
REDUCING FLANGED FLEXIBLE PUMP CONNECTOR**

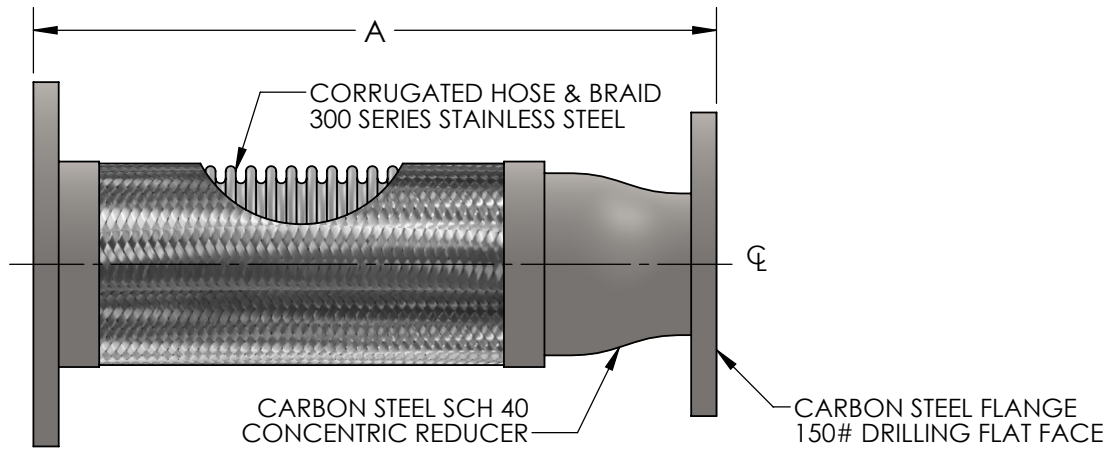

QTY	PART NUMBER	PIPE SIZE		A	PRESSURE RATING (PSI)*	WEIGHT (LBS)	PROJECT INFORMATION
		LARGER	SMALLER				
	RMF0215	2"	1-1/2"	12-1/4"	516	10	
	RMF2502	2-1/2"	2"	12-1/4"	387	15	
	RMF0315	3"	1-1/2"	12-1/4"	316	17	
	RMF0302		2"				
	RMF0325		2-1/2"				
	RMF0402	4"	2"	12-3/4"	232	22	
	RMF0425		2-1/2"				
	RMF0403		3"				
	RMF0525	5"	2-1/2"	15-3/4"	191	31	
	RMF0503		3"				
	RMF0504		4"				
	RMF0602	6"	2"	16-1/4"	165	36	
	RMF0625		2-1/2"				
	RMF0603		3"				
	RMF0604		4"				
	RMF0605		5"				
	RMF0804	8"	4"	17-1/2"	234	65	
	RMF0805		5"				
	RMF0806		6"				
	RMF1006	10"	6"	19-1/2"	230	97	
	RMF1008		8"				
	RMF1206		6"				
	RMF1208	12"	8"	21-1/2"	161	137	
	RMF1210		10"				

\*FOR SAFE WORKING PRESSURE ABOVE 70°F, MULTIPLY THE PRESSURE SHOWN AT 70°F TIMES THE CORRECTION FACTOR OF THE REQUIRED TEMPERATURE.

TEMPERATURE (°F)	FACTOR
70	1.0
200	.91
300	.85
400	.78
500	.77
600	.76

MAX INTERMITTENT OFFSET FROM CENTERLINE 1/8"  
MAX PERMANENT OFFSET FROM CENTERLINE 3/8"

**NSF 372 - LEAD FREE**

The wetted surface of this product contacted by consumable water contains less than one quarter of one percent (0.25%) of lead by weight. Material complies with state codes and standards, where applicable, requiring reduced lead content. Not suitable for potable water systems due to materials of construction.

2	RMF1210 ADDED	6/25/2019
REV. 1	TEMP FACTOR UPDATED	DATE 12/28/2016

**Metraflex**  
for pipes in motion

2323 W. HUBBARD ST.  
CHICAGO, IL 60612  
TEL: 312-738-3800  
FAX: 312-738-0415  
WWW.METRAFLEX.COM

CUSTOMER: \_\_\_\_\_

PROJECT: \_\_\_\_\_

ENGINEER: \_\_\_\_\_

<b>MODEL RMF</b>	
REDUCING FLANGED FLEXIBLE PUMP CONNECTOR	
DRAWN BY: <b>DKISH</b>	DATE: <b>1/10/2014</b>
APPROVED: <b>JC</b>	DATE: <b>1/10/2014</b>
SCALE: <b>N/A</b>	DRAWING NUMBER: <b>RMF-2</b>