

SGB SLIDE GUIDE FOR SIZES 5" - 8"

SPECIFICATIONS:

1. PRE-ENGINEERED TO SAVE CALCULATION AND INSTALLATION TIME.
2. BASES HAVE PTFE SLIDE BEARING PADS COMPOSED OF 100% VIRGIN POLYTETRAFLUOROETHYLENE.
3. SLIDES ARE FABRICATED CARBON STEEL SUPPORTS, BEARING SURFACES HAVE A POWDER COATED FINISH, PROVIDING A FLAT SMOOTH SURFACE.
4. CAPABLE OF SUPPORTING CONSTANT LOADS UP TO 2,000 PSI @ 70°F.
5. PTFE SLIDE ASSEMBLIES PERMIT SMOOTH, UNRESTRAINED MOVEMENT OF THE PIPE AND REDUCE OVERTURNING MOMENTS ON THE SUPPORT STRUCTURE.
6. PTFE IS CHEMICALLY INERT AND RESISTS ATTACK BY CHEMICALS, HUMIDITY, AND OTHER ELEMENTS FOUND IN HARSH ENVIRONMENTS.
7. SELF-LUBRICATING & MAINTENANCE FREE.
8. MAX TEMPERATURE: 400°F.

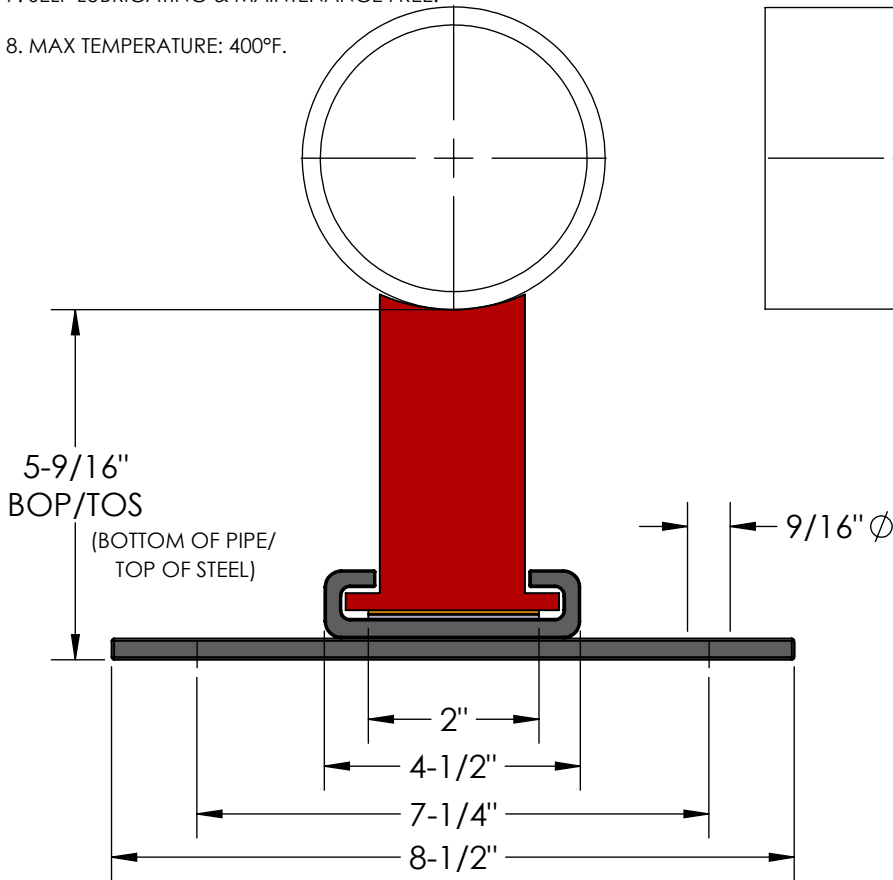
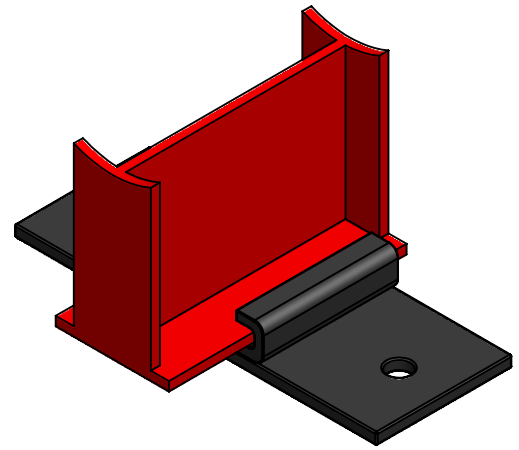

| QTY | L | AXIAL MOVEMENT | WEIGHT | MAX INSULATION THICKNESS |
|-----|-----|----------------|---------|--------------------------|
| | 6" | 4" | 4.9 LBS | 3-1/2" |
| | 12" | 10" | 9.2 LBS | |

MATERIAL: ASTM A36 CARBON STEEL
FINISH: POWDER COATED

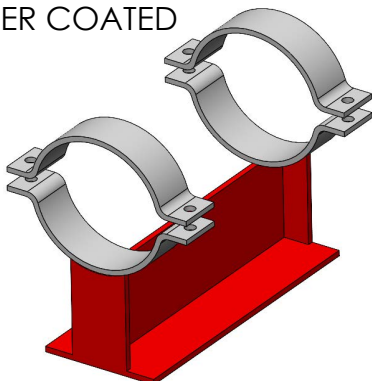

CLAMP OPTION AVAILABLE

| REV. | DATE |
|---|----------------------------|
| | |
| 2323 W. HUBBARD ST. CHICAGO, IL 60612 TEL: 312-738-3800 FAX: 312-738-0415 WWW.METRAFLEX.COM | |
| MODEL SGB BOLT-DOWN BASE SLIDE GUIDE ASSEMBLY 5" - 8" | |
| DRAWN BY: DEVINR | DATE: 8/24/2022 |
| APPROVED: | DATE: |
| SCALE: N/A | DRAWING NUMBER: SGB050-080 |