

Size I.D. (in)	Flange Thickness (in)	Diameter "A" (in)	Diameter "B" (in)	Overall O.D. (in)	# Of Holes	Thread Size	Bolt Size	Flange Bolt Torque (ft-lbs)
1	5/16	4-1/4	5-1/8	6	4	1/2-12UNC	1/2" - 13 x 1"	18
1-1/2	11/32	5	5-7/8	6-3/4	4	1/2-12UNC	1/2" - 13 x 1-1/4"	18
2	7/16	6	6-7/8	8-1/8	4	5/8-11UNC	5/8" - 11 x 1-1/2"	45
2-1/2	1/2	7	8-1/8	9-3/8	4	5/8-11UNC	5/8" - 11 x 1-3/4"	45
3	1/2	7-1/2	8-3/4	10	4	5/8-11UNC	5/8" - 11 x 1-3/4"	45
4	5/8	9	9-7/8	11-1/8	8	5/8-11UNC	5/8" - 11 x 2"	45
5	3/4	10	11-1/2	13	8	3/4-10UNC	3/4" - 10 x 2"	89
6	3/4	11	12-1/2	14	8	3/4-10UNC	3/4" - 10 x 2"	89
8	15/16	13-1/2	14-3/4	16-1/4	8	3/4-10UNC	3/4" - 10 x 2-1/2"	89
10	1	16	17-1/2	19	12	7/8-9UNC	7/8" - 9 x 2-1/2"	121
12	1	19	20-1/2	22	12	7/8-9UNC	7/8" - 9 x 2-1/2"	121

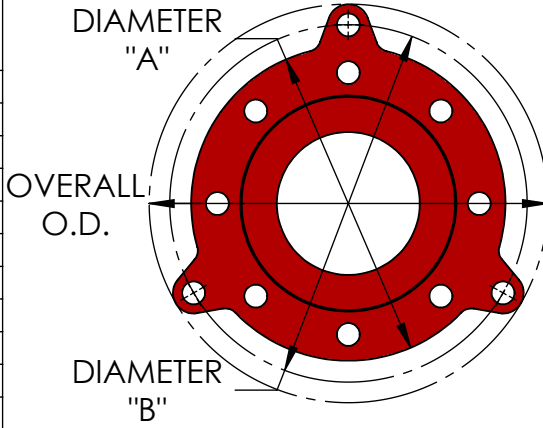

*Limit bolts are factory set to prevent extension. If extension is required, the stop nut must be adjusted.

MAXIMUM PRESSURE (PSI) VS TEMPERATURE

Qty	Size I.D. (in)	F/F (in)	Maximum Axial Travel (in)	Maximum Offset (in)	MAXIMUM PRESSURE (PSI) VS TEMPERATURE				Weight (Lbs)	Vacuum Rating (in. Hg/°F)
					70°F	200°F	300°F	400°F		
	1	1-3/8	1/4	1/8	170	135	100	70	2	29.9/425
	1-1/2	1-3/8	1/4	1/8	170	135	100	70	3	29.9/425
	2	1-9/16	1/4	1/8	170	135	95	65	7	29.9/425
	2-1/2	2-1/4	5/16	1/8	165	130	95	65	10	29.9/425
	3	2-1/4	3/8	3/16	165	125	90	60	12	29.9/425
	4	2-5/8	1/2	1/4	160	125	85	60	18	29.9/400
	5	3-1/4	1/2	1/4	155	120	85	60	24	29.9/400
	6	2-3/4	1/2	1/4	150	115	85	55	29	29.9/400
	8	4	1/2	1/4	145	110	80	55	47	29.9/250
	10	5-1/4	1/2	1/4	140	110	80	55	64	29.9/250
	12	6	1/2	1/4	135	105	75	50	72	29.9/75

Note: Angular Deflection approx. 7 degrees. Maximum Axial Travel is based on installation with no misalignment or angular deflection. Maximum Offset is based on installation at neutral length with limit bolts in place.

Project Info

CUSTOMER: _____

PROJECT: _____

ENGINEER: _____

REV. 1	Bolt size & torque added	DATE 11/02/2022
		2323 W. HUBBARD ST. CHICAGO, IL 60612 TEL: 312-738-3800 FAX: 312-738-0415 WWW.METRAFLEX.COM
<h2>MODEL T1C</h2> <h3>PTFE MOLDED FLEXIBLE COUPLING</h3>		
DRAWN BY: DKISH		DATE: 8/11/2014
APPROVED: DANH		DATE: 8/11/2014
SCALE: NONE	DRAWING NUMBER: T1C-1	