

## 100C TAPERED EXPANSION JOINT/ PUMP CONNECTOR

ITEM	PART NAME	MATERIAL
1	BODY	BUTYL & NYLON
2	RETAINING RING	CARBON STEEL

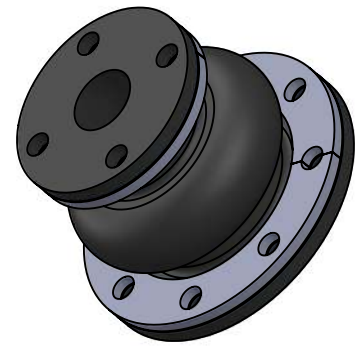

MAXIMUM WORKING  
TEMPERATURE 230°F

MOVEMENT CAPABILITY

AXIAL DEFLECTION

Qty.	Model #	A	B	Minimum F/F (in)	Pressure (PSI)	Vacuum (in Hg)	MOVEMENT CAPABILITY				Weight With Rings (Lbs)
							Compression (in)	Elongation (in)	Lateral (in)	Angular (Degrees)	
	100C2X1X6	2	1	6	165	26	1/2	1/4	1/2	3	8
	100C2X1.5X6	2	1.5	6	165	26	1/2	1/4	1/2	3	8
	100C2.5X1.5X6	2.5	1.5	6	165	26	1/2	1/4	1/2	3	10
	100C2.5X2X6	2.5	2	6	165	26	1/2	1/4	1/2	3	11
	100C3X1.5X6	3	1.5	6	165	26	1/2	1/4	1/2	3	11
	100C3X2X6	3	2	6	165	26	1/2	1/4	1/2	3	12
	100C3X2.5X6	3	2.5	6	165	26	1/2	1/4	1/2	3	13
	100C4X2X6	4	2	6	165	26	1/2	1/4	1/2	3	15
	100C4X2.5X6	4	2.5	6	165	26	1/2	1/4	1/2	3	16
	100C4X3X6	4	3	6	165	26	1/2	1/4	1/2	3	18
	100C5X3X6	5	3	6	140	26	1/2	1/4	1/2	3	17
	100C5X4X6	5	4	6	140	26	1/2	1/4	1/2	3	18
	100C6X2X8	6	2	8	140	26	1/2	1/4	1/2	3	18
	100C6X2.5X6	6	2.5	6	140	26	1/2	1/4	1/2	3	19
	100C6X3X6	6	3	6	140	26	1/2	1/4	1/2	3	19
	100C6X4X6	6	4	6	140	26	1/2	1/4	1/2	3	20
	100C6X4X8	6	4	8	140	26	1/2	1/4	1/2	3	24
	100C6X5X6	6	5	6	140	26	1/2	1/4	1/2	3	26
	100C8X3X6	8	3	6	140	26	3/4	3/8	1/2	3	26
	100C8X4X6	8	4	6	140	26	3/4	3/8	1/2	3	28
	100C8X4X8	8	4	8	140	26	3/4	3/8	1/2	3	30
	100C8X5X6	8	5	6	140	26	3/4	3/8	1/2	3	31
	100C8X6X6	8	6	6	140	26	3/4	3/8	1/2	3	33
	100C8X6X8	8	6	8	140	26	3/4	3/8	1/2	3	34
	100C10X5X8	10	5	8	140	26	3/4	3/8	1/2	3	36
	100C10X6X8	10	6	8	140	26	3/4	3/8	1/2	3	38
	100C10X8X6	10	8	6	140	26	3/4	3/8	1/2	3	40
	100C10X8X8	10	8	8	140	26	3/4	3/8	1/2	3	43
	100C12X6X8	12	6	8	140	26	3/4	3/8	1/2	3	48
	100C12X8X6	12	8	6	140	26	3/4	3/8	1/2	3	50
	100C12X8X8	12	8	8	140	26	3/4	3/8	1/2	3	53
	100C12X10X8	12	10	8	140	26	3/4	3/8	1/2	3	59
	100C14X8X8	14	8	8	85	15	3/4	3/8	1/2	2	65
	100C14X10X8	14	10	8	85	15	3/4	3/8	1/2	2	68
	100C14X12X8	14	12	8	85	15	3/4	3/8	1/2	2	70
	100C16X10X8	16	10	8	65	15	3/4	3/8	1/2	2	78
	100C16X12X8	16	12	8	65	15	3/4	3/8	1/2	2	81
	100C16X14X8	16	14	8	65	15	3/4	3/8	1/2	2	89
	100C18X12X8	18	12	8	65	15	3/4	3/8	1/2	1	88
	100C18X14X8	18	14	8	65	15	3/4	3/8	1/2	1	90
	100C18X16X8	18	16	8	65	15	3/4	3/8	1/2	1	99

### NOTES

REV.

DATE

**Metraflex**  
for pipes in motion

2323 W. HUBBARD ST.  
CHICAGO, IL 60612  
TEL: 312-738-3800  
FAX: 312-738-0415  
WWW.METRAFLEX.COM

## CONCENTRIC REDUCER

TAPERED EXPANSION JOINT/PUMP CONNECTOR

DRAWN BY: **DKISH**

DATE: **11/7/2014**

APPROVED: **JC**

DATE: **11/7/2014**

SCALE:

NONE

DRAWING NUMBER:

100C

CUSTOMER: \_\_\_\_\_

PROJECT: \_\_\_\_\_

ENGINEER: \_\_\_\_\_