

RISER ANCHOR CLAMP - MODEL RAC
PIPE ANCHOR / RISER CLAMP FOR STEEL RISERS
SUITABLE FOR CARBON STEEL SCH STD / SCH XS AND STAINLESS STEEL SCH 40S

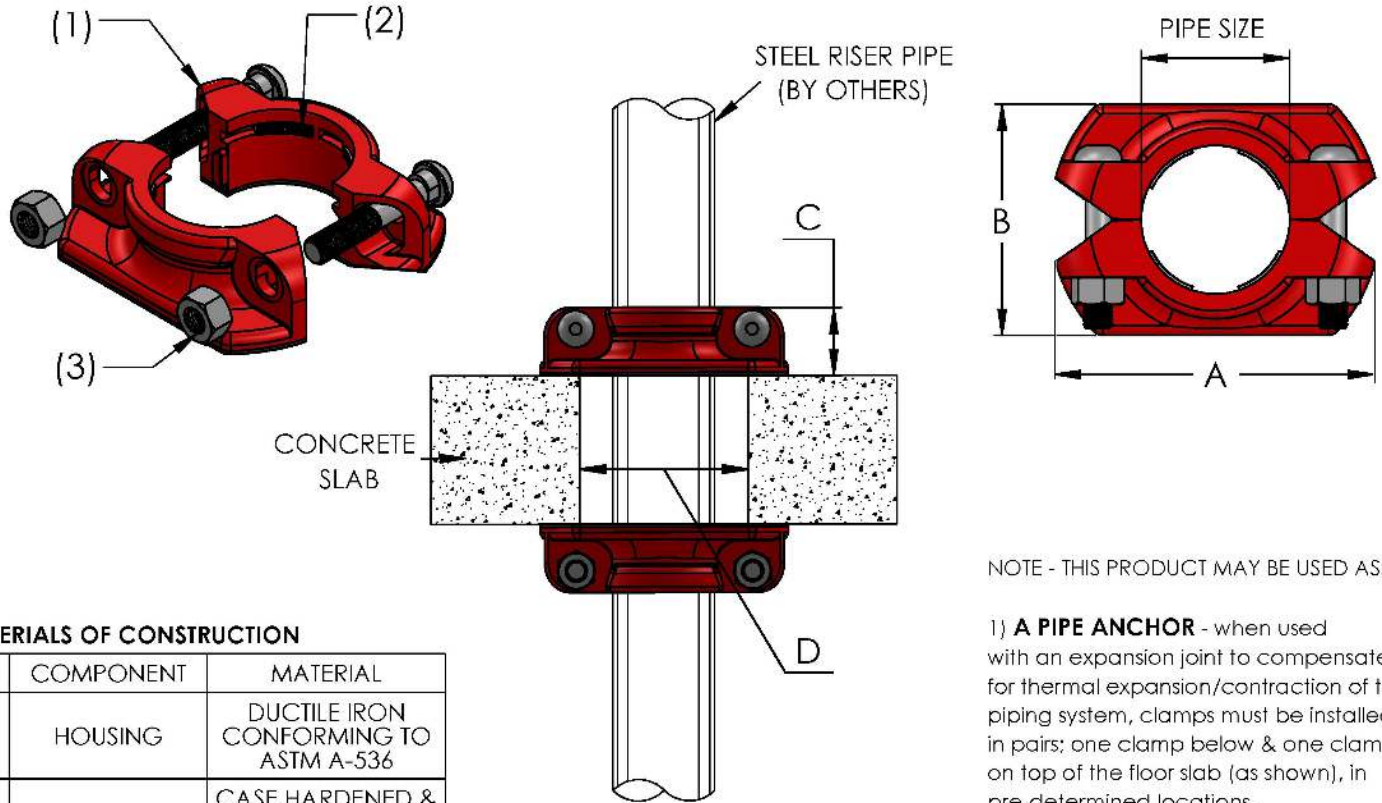

NOTE - THIS PRODUCT MAY BE USED AS:

1) **A PIPE ANCHOR** - when used with an expansion joint to compensate for thermal expansion/contraction of the piping system, clamps must be installed in pairs: one clamp below & one clamp on top of the floor slab (as shown), in pre-determined locations.

2) **A RISER CLAMP** - when used as a vertical pipe support, only one clamp is required, installed on the top of the floor slab.

MATERIALS OF CONSTRUCTION

ITEM	COMPONENT	MATERIAL
1	HOUSING	DUCTILE IRON CONFORMING TO ASTM A-536
2	GRIPPING TEETH	CASE HARDENED & ELECTROPLATED CARBON STEEL
3	NUTS AND BOLTS	ELECTROPLATED CARBON STEEL

*STAINLESS STEEL TEETH ARE AVAILABLE

QTY	PART NUMBER	PIPE SIZE		A	B	C	D MAX. RISER HOLE DIAMETER	BOLT/NUT SIZE (2 per clamp)	REQUIRED BOLT TORQUE (Lb.Ft)	MAXIMUM* ANCHOR LOAD (Lbs)
		INCH	MM							
	RAC0250	2-1/2"	65	6-5/8"	5"	2-1/8"	4-1/2"	3/4" x 3-1/4	150	9000
	RAC0300	3"	80	7-3/4"	5-1/2"	2-5/8"	5-1/2"	3/4" x 4-1/4	200	10000
	RAC0400	4"	100	9-5/8"	7"	2-1/2"	6-1/2"	7/8" x 5	250	20000
	RAC0500	5"	125	12"	8-3/8"	2-3/4"	8-1/2"	7/8" x 5	250	25000
	RAC0600	6"	150	14-3/8"	11-1/4"	2-3/4"	10-1/2"	1" x 6	250	30000
	RAC0800	8"	200	18-7/8"	13-1/2"	5-1/8"	12-1/2"	1" x 6	250	50000

*FOR USE AS A **PIPE ANCHOR**, STRUCTURAL ENGINEERS MUST CONFIRM CONCRETE SLAB IS SUFFICIENT TO WITHSTAND GIVEN LOAD. TYPICAL LOADS (CREATED BY THRUST LOAD OF EXPANSION JOINT) ARE CONSIDERABLY LESS THAN THE MAX LOAD RATING OF THE CLAMP. FOR USE AS A **RISER CLAMP**, LOAD IS ONLY FROM WEIGHT OF PIPE.

CUSTOMER: _____

PROJECT: _____

ENGINEER: _____

REV.	DATE
2323 W. HUBBARD ST. CHICAGO, IL 60612 TEL: 312-738-3800 FAX: 312-738-0415 WWW.METRAFLEX.COM	
RISER ANCHOR CLAMP PIPE ANCHOR / RISER CLAMP FOR STEEL RISERS	
DRAWN BY: DKISH	DATE: 6/28/2017
APPROVED: ZB	DATE: 6/28/2017
SCALE: N/A	DRAWING NUMBER: RAC-1