

MIGHTYSPHERE MODEL MSDKSEE, KEVLAR REINFORCED EPDM EXPANSION JOINT, 150# FLANGED

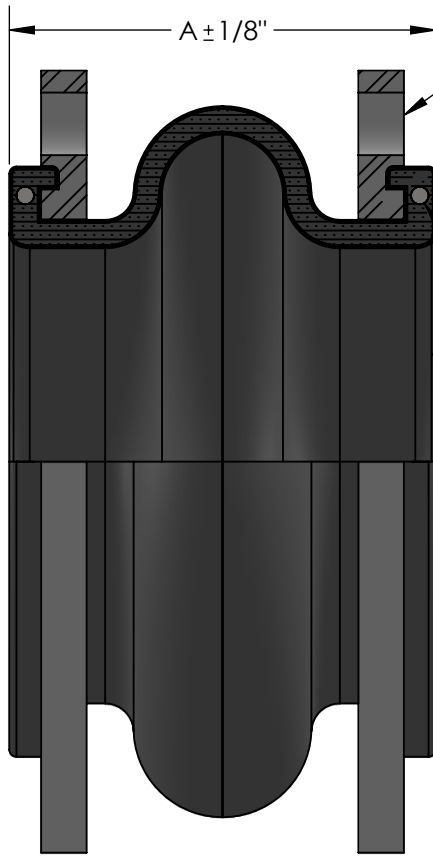

INSTALL WITH WASHER AT SPLIT IN FLANGE (WASHER BY OTHERS)

BOLT HOLE SIZE

FORGED STEEL SPLIT 150# FLOATING FLANGES

SOLID STEEL ANCHOR RING

MULTI-LAYERED (KEVLAR) TIRE-CORD REINFORCEMENT WITH PEROXIDE CURED EPDM

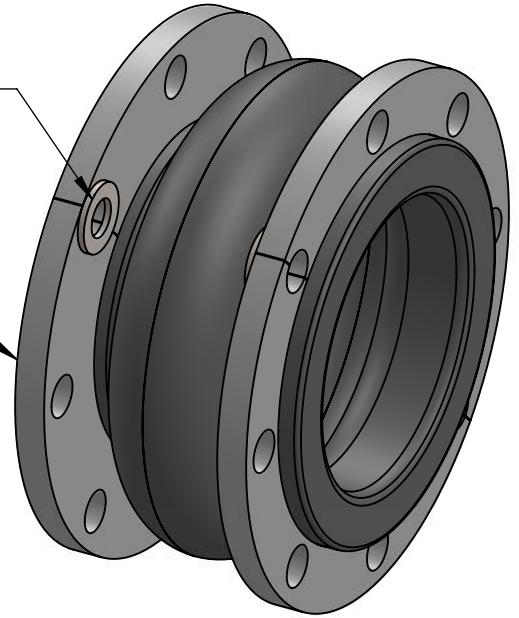

NSF 372 - LEAD FREE

The wetted surface of this product contacted by consumable water contains less than one quarter of one percent (0.25%) of lead by weight. Material complies with state codes and standards, where applicable, requiring reduced lead content.

NOTES:

WWW.METRAFLEX.COM FOR INSTALLATION INSTRUCTIONS. JOINT MUST BE INSTALLED AT ITS NEUTRAL LENGTH. BOLTS MUST BE PROPERLY TORQUED. NOT SUITABLE FOR STEAM OR VACUUM APPLICATIONS. IF CONNECTING PIPE IS NOT ANCHORED AND GUIDED, CONTROL UNITS MUST BE USED.

QTY	PART NUMBER	PIPE SIZE		A	AXIAL COMP.	FORCE (LBS)	AXIAL EXT.	FORCE (LBS)	LATERAL OFFSET	FORCE (LBS)	ANGULAR	WEIGHT (LBS)	BOLT HOLE SIZE
		INCH	MM										
	MSRDKSEE0200	2"	50	6"	1/2"	55	3/16"	73	3/8"	55	15°	8	3/4"
	MSRDKSEE0250	2-1/2"	65	6"	1/2"	102	3/16"	68	3/8"	97	15°	13	3/4"
	MSRDKSEE0300	3"	80	6"	1/2"	136	3/16"	115	3/8"	108	15°	14	3/4"
	MSRDKSEE0400	4"	100	6"	5/8"	145	3/16"	242	3/8"	275	15°	18	3/4"
	MSRDKSEE0500	5"	125	6"	5/8"	172	3/16"	196	3/8"	308	15°	23	7/8"
	MSRDKSEE0600	6"	150	6"	5/8"	293	3/16"	563	3/8"	484	15°	28	7/8"
	MSRDKSEE0800	8"	200	6"	5/8"	372	3/16"	587	3/8"	688	15°	40	7/8"
	MSRDKSEE1000	10"	250	8"	3/4"	398	1/4"	455	1/2"	781	15°	68	1"
	MSRDKSEE1200	12"	300	8"	3/4"	390	1/4"	356	1/2"	842	15°	94	1"

MAXIMUM OPERATING CONDITIONS

TEMPERATURE	PRESSURE	VACUUM
170°F	250 PSI	16 in. Hg.
190°F	245 PSI	16 in. Hg.
210°F	235 PSI	16 in. Hg.
230°F	225 PSI	16 in. Hg.
250°F	215 PSI	16 in. Hg.

MAXIMUM WORKING TEMPERATURE 250°F

TO BE FURNISHED WITH CONTROL UNITS:

YES NO

CUSTOMER: _____

PROJECT: _____

ENGINEER: _____

REV.	DATE
2323 W. HUBBARD ST. CHICAGO, IL 60612 TEL: 312-738-3800 FAX: 312-738-0415 WWW.METRAFLEX.COM	
MIGHTYSPHERE MODEL MSRDKSEE EPDM EXPANSION JOINT, 150# FLANGES	
DRAWN BY: DKISH	DATE: 7/10/2018
APPROVED:	DATE:
SCALE: N/A	DRAWING NUMBER: MSDKSEE-1