

SGB SLIDE GUIDE FOR SIZES 10" - 24"

SPECIFICATIONS:

1. PRE-ENGINEERED TO SAVE CALCULATION AND INSTALLATION TIME.
2. BASES HAVE PTFE SLIDE BEARING PADS COMPOSED OF 100% VIRGIN TETRAFLUOROETHYLENE POLYMER.
3. SLIDES ARE FABRICATED CARBON STEEL SUPPORTS, BEARING SURFACES HAVE A POWDER COATED FINISH, PROVIDING A FLAT SMOOTH SURFACE.
4. CAPABLE OF SUPPORTING CONSTANT LOADS UP TO 2,000 PSI AT 70°F.
5. PTFE SLIDE ASSEMBLIES PERMIT SMOOTH, UNRESTRAINED MOVEMENT OF THE PIPE AND REDUCE OVERTURNING MOMENTS ON THE SUPPORT STRUCTURE.
6. PTFE IS CHEMICALLY INERT AND RESISTS ATTACK BY CHEMICALS, HUMIDITY AND OTHER ELEMENTS FOUND IN HARSH ENVIRONMENTS.
7. SELF-LUBRICATING, MAINTENANCE FREE.
8. MAXIMUM TEMPERATURE: 400°F.

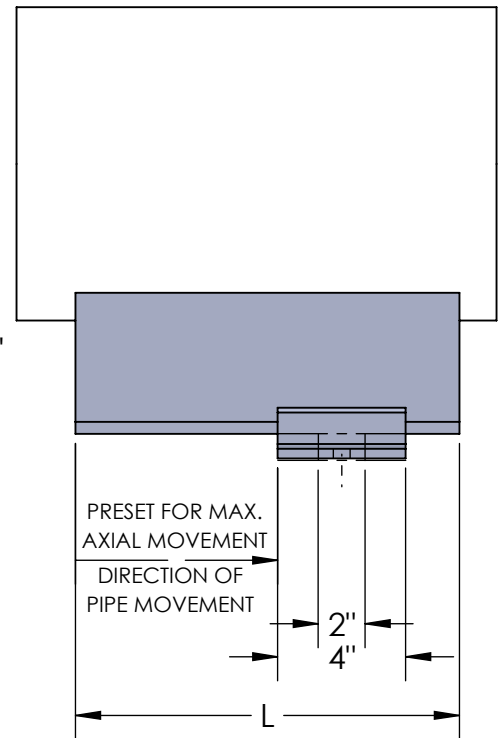
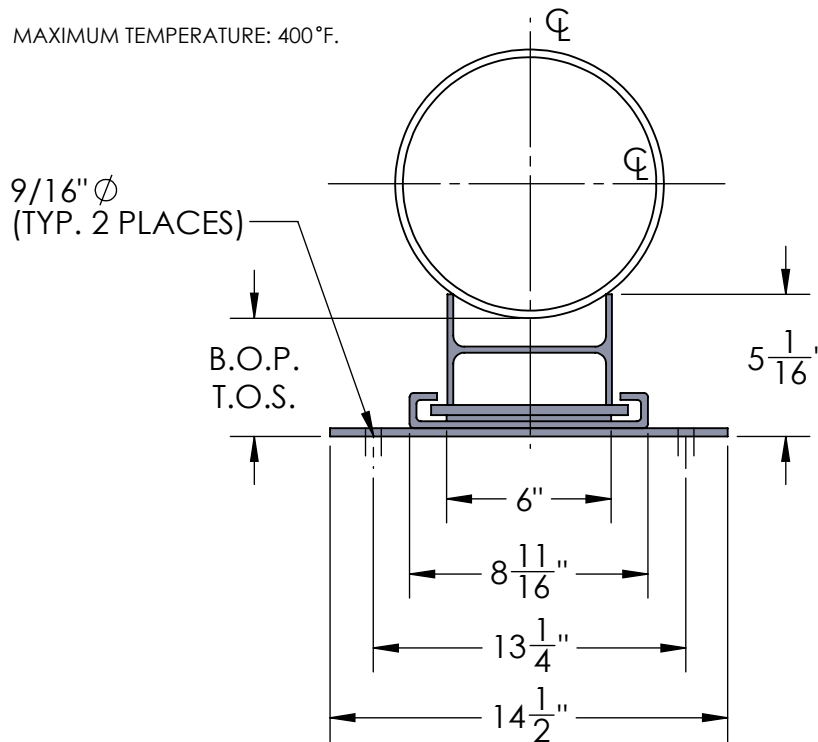
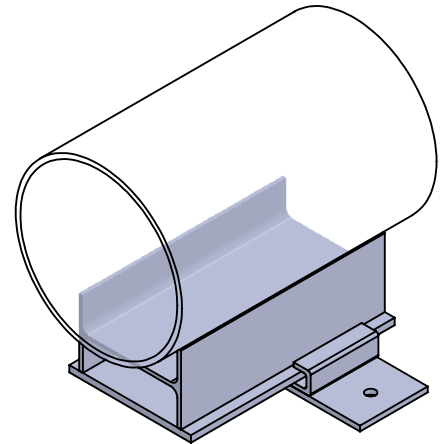

MAX. INSULATION THICKNESS: 3-1/2"

AXIAL MOVEMENT	L	WEIGHT
4"	6"	16.41 LBS
10"	12"	26.31 LBS

PIPE SIZE	BOP/TOS	Φ
10"	4-3/8"	9-3/4"
12"	4-1/2"	10-7/8"
14"	4-5/8"	11-5/8"
16"	4-5/8"	12-5/8"
18"	4-5/8"	13-5/8"
20"	4-3/4"	14-3/4"
24"	4-7/8"	16-7/8"

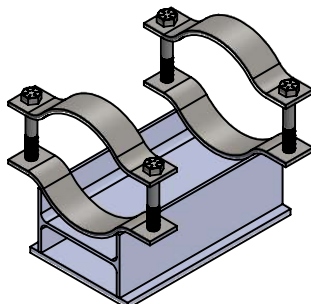

CLAMP OPTION AVAILABLE

REV.	DATE	
2323 W. HUBBARD ST. CHICAGO, IL 60612 TEL: 312-738-3800 FAX: 312-738-0415 WWW.METRAFLEX.COM		
SLIDE GUIDE ASSEMBLY MODEL SGB BOLT DOWN BASE, 10" - 24"		
DRAWN BY: RDAHYA	DATE: 12/07/2020	
APPROVED:	DATE:	
SCALE: N/A	DRAWING NUMBER: SGB100-240	