

**MODEL HPF3  
HIGH PRESSURE  
EXTERNALLY PRESSURIZED  
EXPANSION COMPENSATOR**

HOUSING CUT AWAY TO SHOW BELLOWS

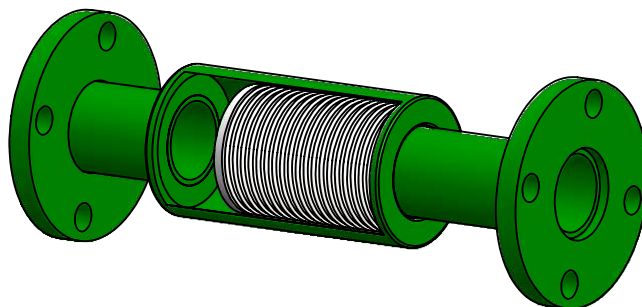

**DESIGN DATA**

CONFORMS TO MIL-DTL-17813H  
 MAXIMUM WORKING TEMPERATURE: 500° (260°C)  
 MAXIMUM WORKING PRESSURE: 175 PSI (1206 kPa)  
 MAXIMUM TEST PRESSURE: 250 PSI (1809 kPa) @ 70°F  
 AXIAL COMPRESSION: 3" (80mm)  
 AXIAL EXTENSION: 1/2" (13mm)

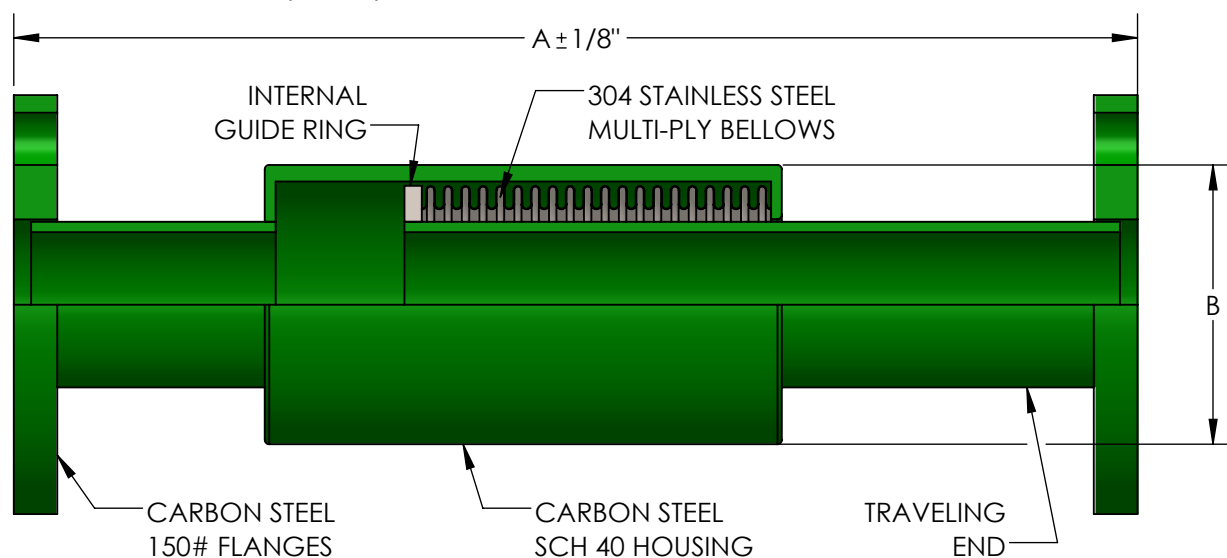

THIS EXPANSION JOINT IS DESIGNED FOR AXIAL MOVEMENT ONLY. PIPE MUST BE PROPERLY GUIDED AND ANCHORED PER THE RECOMMENDATIONS OF THE EXPANSION JOINT MANUFACTURERS ASSOCIATION.

QTY	PART NUMBER	PIPE SIZE		A	B	EFFECTIVE AREA (in <sup>2</sup> )	SPRING RATE (lb/in)	WEIGHT	PROJECT INFORMATION
		INCH	MM						
	HPF30075	3/4"	20	17-1/8"	3"	1.5	58	9	
	HPF30100	1"	25	17-1/8"	3"	2.1	63	12	
	HPF30125	1-1/4"	32	17-1/8"	3"	3.3	52	13	
	HPF30150	1-1/2"	38	18-1/8"	3-1/2"	4.3	82	15	
	HPF30200	2"	50	18-1/8"	4"	6.3	117	20	
	HPF30250	2-1/2"	65	19-3/8"	5"	8.8	132	31	
	HPF30300	3"	80	19-7/8"	5-1/2"	13.1	161	36	
	HPF30400	4"	100	19-7/8"	6-5/8"	20.8	341	49	

**NSF 372 - LEAD FREE**

The wetted surface of this product contacted by consumable water contains less than one quarter of one percent (0.25%) of lead by weight. Material complies with state codes and standards, where applicable, requiring reduced lead content.

CUSTOMER: \_\_\_\_\_

PROJECT: \_\_\_\_\_

ENGINEER: \_\_\_\_\_

2	Edit temperature-pressure rating. Add compliance	01/07/2021
REV. 1	Edit B dimension to 3" on lines 1 and 2. DATE: 08/27/2019	
		2323 W. HUBBARD ST. CHICAGO, IL 60612 TEL: 312-738-3800 FAX: 312-738-0415 WWW.METRAFLEX.COM
<b>MODEL HPF3</b> HIGH PRESSURE EXPANSION COMPENSATOR		
DRAWN BY: <b>DKISH</b>		DATE: <b>9/3/2015</b>
APPROVED: <b>JC</b>		DATE: <b>9/3/2015</b>
SCALE: N/A	DRAWING NUMBER: <b>HPF3</b>	