

**MODEL HPFF3
HIGH PRESSURE
EXTERNALLY PRESSURIZED
EXPANSION COMPENSATOR**

HOUSING CUT AWAY TO SHOW BELLOWS

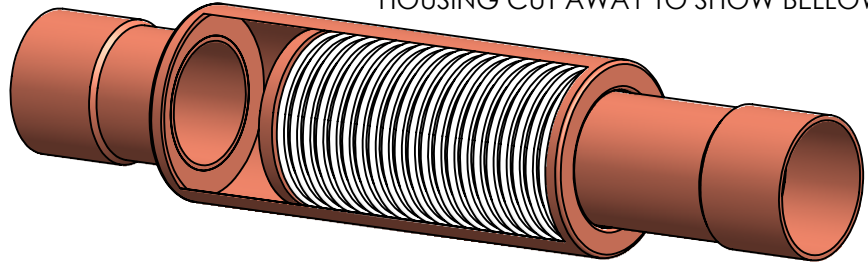

DESIGN DATA

TEMPERATURE: 400° (204°C)*
 PRESSURE: 150 PSI (1034 kPa)*
 TEST PRESSURE: 225 PSI (1551 kPa)
 AXIAL COMPRESSION: 3" (80mm)
 AXIAL EXTENSION: 1/2" (13mm)

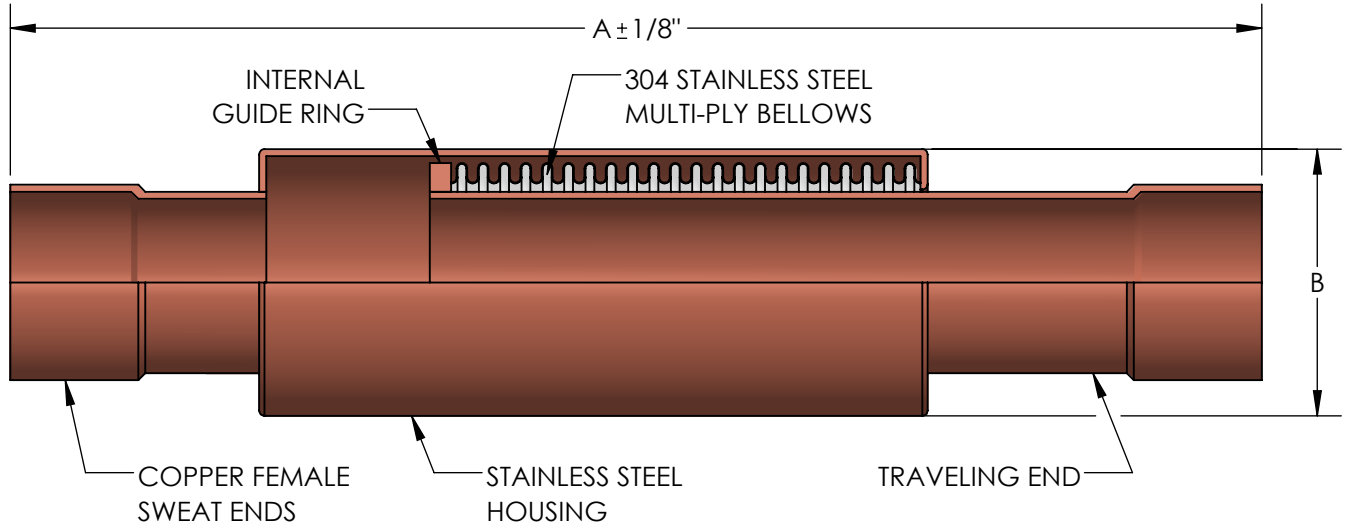

THIS EXPANSION JOINT IS DESIGNED FOR AXIAL MOVEMENT ONLY. PIPE MUST BE PROPERLY GUIDED AND ANCHORED PER THE RECOMMENDATIONS OF THE EXPANSION JOINT MANUFACTURERS ASSOCIATION.

QTY	PART NUMBER	TUBE SIZE		A	B	EFFECTIVE AREA (in ²)	SPRING RATE (lb/in)	WEIGHT	PROJECT INFORMATION
		INCH	MM						
	HPFF30075	3/4"	20	14-7/8"	1-5/8"	1.1	58	1	
	HPFF30100	1"	25	15-1/8"	2"	1.7	63	1-1/2	
	HPFF30125	1-1/4"	32	16-3/8"	2-1/4"	2.4	54	2	
	HPFF30150	1-1/2"	38	16-3/4"	2-1/2"	3.2	52	3	
	HPFF30200	2"	50	17"	3"	5.1	118	4	
	HPFF30250	2-1/2"	65	17"	4"	7.6	110	5	
	HPFF30300	3"	80	18"	4-1/2"	10.6	175	6	
	HPFF30400	4"	100	19"	5-7/8"	17.9	241	12	

CAUTION: SILVER BRAZING USED IN CONSTRUCTION. DO NOT EXCEED 1000°F DURING INSTALLATION.

*PRESS SYSTEMS: COMPENSATORS PRODUCE FORCES THAT MAY EXCEED THE TENSILE STRENGTH OF THE PRESS FITTING. MAX TEMPERATURE FOR PRESS SYSTEMS IS 250°F. CONTACT FACTORY FOR USE IN PRESS SYSTEMS.

NSF 372 - LEAD FREE

The wetted surface of this product contacted by consumable water contains less than one quarter of one percent (0.25%) of lead by weight. Material complies with state codes and standards, where applicable, requiring reduced lead content.

CUSTOMER: _____

PROJECT: _____

ENGINEER: _____

2	PRESS SYSTEMS NOTE	10/6/2020
REV. 1	HOUSING UPDATED	DATE 5/20/2020
		2323 W. HUBBARD ST. CHICAGO, IL 60612 TEL: 312-738-3800 FAX: 312-738-0415 WWW.METRAFLEX.COM
MODEL HPFF3		
HIGH PRESSURE EXPANSION COMPENSATOR		
DRAWN BY: DKISH		DATE: 9/3/2015
APPROVED: JC		DATE: 9/3/2015
SCALE: N/A	DRAWING NUMBER: HPFF3-2	